

LOS ANGELES POLICE COMMISSION

BOARD OF
POLICE COMMISSIONERS

JOHN W. MACK
PRESIDENT

ALAN J. SKOBIN
VICE PRESIDENT

RICHARD DROOYAN
ROBERT M. SALTZMAN
DEBRA WONG YANG

MARIA SILVA
COMMISSION EXECUTIVE ASSISTANT I



ANTONIO R. VILLARAIGOSA
MAYOR

RICHARD M. TEFANK
EXECUTIVE DIRECTOR

NICOLE C. BERSHON
INSPECTOR GENERAL

EXECUTIVE OFFICE
POLICE ADMINISTRATION BUILDING
100 WEST FIRST STREET, SUITE 134
LOS ANGELES, CA 90012-4112

(213) 236-1400 PHONE
(213) 236-1410 FAX
(213) 236-1440 TDD

March 21, 2011

BPC #11-0109

The Honorable Antonio Villaraigosa
Mayor, City of Los Angeles
City Hall, Room 303
Los Angeles, CA 90012

The Honorable City Council
City of Los Angeles
c/o City Clerk's Office

Dear Honorable Members:

RE: TRANSMITTAL OF THE GRANT APPLICATION FOR THE 2010-11 PROJECT SAFE
NEIGHBORHOODS PROGRAM

At the regular meeting of the Board of Police Commissioners held Tuesday, March 15, 2010, the Board APPROVED the Department's report relative to the above matter.

This matter is being forwarded to you for approval.

Respectfully,

BOARD OF POLICE COMMISSIONERS

A handwritten signature in cursive script that reads "Maria Silva".

MARIA SILVA
Commission Executive Assistant

Attachment

c: Chief of Police

8C

INTRADEPARTMENTAL CORRESPONDENCE

March 8, 2011

1.17

TO: The Honorable Board of Police Commissioners

FROM: Chief of Police

Submitted for 3/10/11

SUBJECT: TRANSMITTAL OF THE GRANT APPLICATION FOR THE 2010-2011
PROJECT SAFE NEIGHBORHOODS PROGRAM

RECOMMENDED ACTIONS

1. That the Board of Police Commissioners (Board) TRANSMIT the attached grant application for the Fiscal Year 2010-2011 Project Safe Neighborhoods (PSN) Program, pursuant to Administrative Code Section 14.6(a), to the Offices of the Mayor, City Administrative Officer, and Chief Legislative Analyst, and to the City Clerk for Committee and City Council consideration.
2. That the Board REVIEW and APPROVE this report.
3. That the Board REQUEST the Mayor and City Council to:
 - A. AUTHORIZE the Chief of Police or designee to ACCEPT the award of the 2010-2011 PSN Program funds in the amount of \$42,000 from the California Emergency Management Agency via the U.S. Attorney's Office, for the period of October 1, 2010 through September 30, 2011;
 - B. AUTHORIZE the Chief of Police or designee to execute the Award Agreement and submit any necessary documents relative to the grant award, subject to the City Attorney's approval as to form and legality;
 - C. AUTHORIZE the Chief of Police or designee to execute a Memorandum of Understanding with Aztecs Rising, El Centro del Pueblo, People Assisting the Homeless, Walden House, and Dream Center/Catholic Charities, pending grantor's approval, for the period of October 1, 2010 to September 30, 2011, which will outline a cooperative effort to assist parolees in re-entry into the community and provide gang intervention;
 - D. AUTHORIZE the Controller to set up a grant receivable in the amount of \$42,000 and establish an appropriation account, account number to be determined, within Fund No. 339, Department No. 70 for the disbursements of PSN Grant funds;
 - E. AUTHORIZE the Los Angeles Police Department (LAPD) to expend the grant funds in accordance with the grant award agreement,

- F. AUTHORIZE the Controller to increase appropriations as needed from Fund No. 339, Department No. 70, to Fund No. 100, Department No. 70, as follows:

Account No. 1092, Sworn Overtime: \$20,152

- G. AUTHORIZE the LAPD to submit grant reimbursement requests to grantor and deposit grant funds into Fund No. 339, Department No. 70; and
- H. AUTHORIZE the LAPD to prepare Controller instructions for any technical adjustments, subject to the approval of the City Administrative Officer, and AUTHORIZE and INSTRUCT the Controller to implement the instructions.

DISCUSSION

In response to a State, California Emergency Management Agency, Request for Applications to U.S. Attorney grant recipients, the LAPD submitted the attached application for the 2010-2011 PSN Grant Program. The LAPD has been awarded \$42,000 in funds for the period of October 1, 2010 to September 30, 2011.

In 2009, LAPD's Rampart Area, along with representatives from the Offices of the Mayor, City and District Attorneys, Probation, and its community partners Aztecs Rising, El Centro del Pueblo, People Assisting the Homeless, Walden House, and Dream Center/Catholic Charities, launched the Community Re-Entry Outreach Program (CROP), due to the anticipation and consequences of the early release of parolees to an already volatile and gang infested community.

The Rampart collaborative, consisting of Rampart supervisors, will coordinate across all partner non-profit organizations and work collectively with the intervention and prevention programs to focus on additional strategies and enforcement issues that have been identified with respect to the early release of Non-Revocable Parolees (NRP) within the community. The intent of CROP is to 1) Identify prison inmates to be released into the Rampart community; 2) Conduct early outreach to triage their needs; 3) Attempt to place them into programs that will support their needs as they re-enter society; 4) Provide stable conditions of NRP's re-entry into the community from prison; and, 5) Facilitate growth into being productive community members.

The grant will fund overtime for approximately 23 details consisting of Rampart Gang Impact Team supervisors and officers whose focus will be to make physical contact with prison inmates who are released within Rampart Area, conduct gang enforcement roll-backs on inmates who are identified as gang members, conduct outreach to prison inmates to provide them with a list of available services once they are released into Rampart Area, and to reduce gang crime in Rampart Area.

The Honorable Board of Police Commissioners

Page 3

1.17

The total cost associated with the PSN Grant funding for the Department to implement the additional intervention/enforcement strategy is \$42,000. The funds will supplement CROP's current efforts in this area.

If you have any questions, please contact Captain Regina Scott, Acting Commanding Officer, Information Technology Bureau, at (213) 486-0370.

Respectfully,



CHARLIE BECK
Chief of Police

Attachments

BOARD OF
POLICE COMMISSIONERS
Approved *March 15, 2011*
Secretary *Maria Silva*

ARNOLD SCHWARZENEGGER
GOVERNOR

MATTHEW R. BETTENHAUSEN
SECRETARY



3650 SCHRIEVER AVENUE
MATHER, CA 95655

PHONE (916) 324-9200
FAX (916) 323-1756

CALIFORNIA EMERGENCY MANAGEMENT AGENCY

Application Cover Sheet

RFA PROCESS

PROJECT SAFE NEIGHBORHOODS – CENTRAL DISTRICT

Submitted by:
Los Angeles Police Department
100 West First Street, Suite 842
Los Angeles, California 90012-4112
(213) 486-0380

Cal EMA _____

Award # _____

**CALIFORNIA EMERGENCY MANAGEMENT AGENCY
GRANT AWARD FACE SHEET (Cal EMA 2-101)**

The California Emergency Management Agency, hereafter designated Cal EMA, hereby makes a grant award of funds to the following:

1. **Grant Recipient:** City of Los Angeles

hereafter designated Recipient, in the amount and for the purpose and duration set forth in this grant award.

2. **Implementing Agency:** Los Angeles Police Department

3. **Project Title:** 2010 Project Safe Neighborhoods

4. **Grant Period:** 10/01/10 to 09/30/11

*Select the Grant year and fund source(s) from the lists below or type the appropriate acronym in box 9. Enter the amount(s) from each source. Please do not enter both State and Federal fund sources on the same line. Add any cash match(s). Block 10G is the Grant Award total amount.

Grant Year	Fund Source	A. State	B. Federal	C. Total	D. Cash Match	E. In-Kind Match	F. Total Match	G. Total Project Cost
10/11	5. PSNC	\$42,000					\$0	
Select	6. Select						\$0	
Select	7. Select						\$0	
Select	8. Select						\$0	
Select	9.						\$0	
	10. TOTALS	\$42,000	\$0	\$42,000	\$0	\$0	\$0	10. Grand Total: \$42,000

11. This grant award consists of this title page, the application for the grant, which is attached and made a part hereof, and the Assurance of Compliance forms which are being submitted. I hereby certify I am vested with the authority, and have the approval of the City/County Financial Officer, City Manager, County Administrator, or Governing Board Chair, to enter into this grant award agreement; and all funds received pursuant to this agreement will be spent exclusively on the purposes specified. The grant recipient signifies acceptance of this grant award and agrees to administer the grant project in accordance with the statute(s), the Cal EMA Program Guidelines, the *Cal EMA Recipient Handbook*, the Federal OJP Financial Guide and Program Guidelines (if applicable), and the Cal EMA audit requirements, as stated in the applicable RFP or RFA. The grant recipient further agrees to all legal conditions and terms incorporated by reference in the applicable RFP or RFA, and agrees that the allocation of funds is contingent on the enactment of the State Budget.

12. **Official Authorized to Sign for Applicant/Grant Recipient:** **Federal Employer ID Number:** 95-6000735
Name: Charlie Beck **Title:** Chief of Police
Payment Mailing Address: 100 West First Street, **City:** Los Angeles **Zip:** 90012
Telephone: (213) 486-0150 **FAX:** (213) 486-0168 **Email:** Charlie.Beck@lapd.lacity.org
(area code) (area code)
Signature:  **Date:** 11-29-10

[FOR CalEMA USE ONLY]

I hereby certify upon my own personal knowledge that budgeted funds are available for the period and purposes of this expenditure stated above.

Cal EMA Fiscal Officer

Date

Cal EMA Director (or designee)

Date

CERTIFICATION OF ASSURANCE OF COMPLIANCE

I, Charlie Beck hereby certify that
(official authorized to sign grant award; same person as Section 12 on Grant Award Face Sheet)

RECIPIENT: City of Los Angeles

IMPLEMENTING AGENCY: Los Angeles Police Department

PROJECT TITLE: Community Re-Entry Outreach Program (CROP)

is responsible for reviewing the *Recipient Handbook* and adhering to all of the Grant Award Agreement requirements (state and/or federal) as directed by the Cal EMA including, but not limited to, the following areas:

I. Federal Grant Funds

Recipients expending \$500,000 or more in federal grant funds annually are required to secure an audit pursuant to OMB Circular A-133 and are allowed to utilize federal grant funds to budget for the audit costs. See Section 8000 of the *Recipient Handbook* for more detail.

- The above named Recipient receives \$500,000 or more in federal grant funds annually.
- The above named Recipient does not receive \$500,000 or more in federal grant funds annually.

II. Equal Employment Opportunity — (*Recipient Handbook*, Section 2151)

It is the public policy of the State of California to promote equal employment opportunity by prohibiting discrimination or harassment in employment because of race, religious creed, color, national origin, ancestry, disability (mental and physical) including HIV and AIDS, medical condition (cancer and genetic characteristics), marital status, sex, sexual orientation, denial of family medical care leave, denial of pregnancy disability leave, or age (over 40). **Cal EMA-funded projects certify that they will comply with all state and federal requirements regarding equal employment opportunity, nondiscrimination and civil rights.**

Please provide the following information:

Equal Employment Opportunity Officer: Gloria Grube

Title: Police Administrator Personnel Group

Address: 100 West First Street, Suite 650, Los Angeles, California 90012-4112

Phone: (213) 486-4720

Email: E8547@lapd.lacity.org

III. Drug-Free Workplace Act of 1990 – (Recipient Handbook, Section 2152)

The State of California requires that every person or organization awarded a grant or contract shall certify it will provide a drug-free workplace.

IV. California Environmental Quality Act (CEQA) – (Recipient Handbook, Section 2153)

The California Environmental Quality Act (CEQA) (*Public Resources Code, Section 21000 et seq.*) requires all Cal EMA-funded projects to certify compliance with CEQA. Projects receiving funding must coordinate with their city or county planning agency to ensure that the project is compliance with CEQA requirements.

V. Lobbying – (Recipient Handbook, Section 2154)

Cal EMA grant funds, grant property, or grant-funded positions shall not be used for any lobbying activities, including, but not limited to, being paid by or on behalf of the undersigned, to any person for influencing or attempting to influence an officer or employee of any agency, a Member of Congress, an officer or employee of Congress, or an employee of a Member of Congress in connection with the making of any federal grant, the entering into of any cooperative agreement, and the extension, continuation, renewal, amendment, or modification of any federal grant or cooperative agreement.

VI. Debarment and Suspension – (Recipient Handbook, Section 2155)

(This applies to federally-funded grants only.)

Cal EMA-funded projects must certify that it and its principals are not presently debarred, suspended, proposed for debarment, declared ineligible, sentenced to a denial of federal benefits by a state or federal court, or voluntarily excluded from covered transactions by any federal department or agency.



VII. Proof of Authority from City Council/Governing Board

The above-named organization (Applicant) accepts responsibility for, and will comply with, the requirement to obtain written authorization from the City Council/Governing Board in support of this program. The Applicant agrees to provide all matching funds required for said project (including any amendment thereof) under the Program and the funding terms and conditions of the Cal EMA, and that any cash match will be appropriated as required. It is agreed that any liability arising out of the performance of this Grant Award Agreement, including civil court actions for damages, shall be the responsibility of the Recipient and the authorizing agency. The State of California and the Cal EMA disclaim responsibility of any such liability. Furthermore, it is also agreed that grant funds received from the Cal EMA shall not be used to supplant expenditures controlled by the City Council/Governing Board.

The Applicant is required to obtain written authorization from the City Council/Governing Board that the official executing this agreement is, in fact, authorized to do so. The Applicant is also required to maintain said written authorization on file and readily available upon demand.

All appropriate documentation must be maintained on file by the project and available for the Cal EMA or public scrutiny upon request. Failure to comply with these requirements may result in suspension of payments under the grant or termination of the grant or both and the Recipient may be ineligible for award of any future grants if the Cal EMA determines that any of the following has occurred:

(1) The Recipient has made false certification, or (2) violates the certification by failing to carry out the requirements as noted above.

CERTIFICATION	
I, the official named below, am the same individual authorized to sign the Grant Award Agreement [Section 12 on Grant Award Face Sheet], and hereby swear that I am duly authorized legally to bind the contractor or grant recipient to the above described certification. I am fully aware that this certification, executed on the date and in the county below, is made under penalty of perjury under the laws of the State of California.	
Authorized Official's Signature:	
Authorized Official's Typed Name:	<u>Charlie Beck</u>
Authorized Official's Title:	<u>Chief of Police</u>
Date Executed:	<u>1-18-11</u>
Federal Employer ID #:	<u>95-6000735</u>
Federal DUNS #	<u>03-784-8012</u>
Current Central Contractor Registration	Yes <input checked="" type="checkbox"/> No <input type="checkbox"/>
Executed in the City/County of:	<u>City of Los Angeles/County of Los Angeles</u>
AUTHORIZED BY: <i>(not applicable to State agencies)</i>	
<input checked="" type="checkbox"/> City Financial Officer	<input type="checkbox"/> County Financial Officer
<input type="checkbox"/> City Manager	<input type="checkbox"/> County Manager
<input type="checkbox"/> Governing Board Chair	
Signature:	
Typed Name:	<u>Miguel A. Santana</u>
Title:	<u>City Administrative Officer</u>

PROJECT CONTACT INFORMATION

Applicant City of Los Angeles Grant Number _____ [FOR OES USE ONLY]

Provide the name, title, address, telephone number, and e-mail address for the project contacts named below. If a section does not apply to your project, enter "N/A." NOTE: If you use a PO Box address, a street address is also required for package delivery and site visit purposes.

1. The **Project Director** for the project:

Name: Steven Ruiz Address: 1401 W. 6th Street
Title: Captain III City: Los Angeles Zip: 90017
Telephone #: (213) 484-3010 Fax #: (213) 484-3055
(Area Code) (Area code)
E-Mail Address: 25584@lapd.lacity.org

2. The **Financial Officer** for the project:

Name: Gerald L. Chaleff Address: 100 W. First Street, Suite 1061
Title: Police Administrator III City: Los Angeles Zip: 90012
Telephone #: (213) 486-8730 Fax #: (213) 486-8727
(Area Code) (Area code)
E-Mail Address: N2781@lapd.lacity.org

3. The **person having routine programmatic responsibility** for the project:

Name: Joseph Viguera Address: 1401 W. 6th Street
Title: Sergeant I City: Los Angeles Zip: 90017
Telephone #: (213) 484-3662 Fax #: (213) 484-3656
(Area Code) (Area code)
E-Mail Address: 31537@lapd.lacity.org

4. The **person having routine fiscal responsibility** for the project:

Name: Annette Arredondo Address: 100 W. First Street, Suite 842
Title: Management Analyst II City: Los Angeles Zip: 90012
Telephone #: (213) 486-0381 Fax #: (213) 486-5727
(Area Code) (Area code)
E-Mail Address: N1462@lapd.lacity.org

5. The **Executive Director** of a nonprofit organization or the **Chief Executive Officer** (e.g., chief of police, superintendent of schools) of the implementing agency:

Name: Charlie Beck Address: 100 W. First Street, 10th Floor
Title: Chief of Police City: Los Angeles Zip: 90012
Telephone #: (213) 486-0150 Fax #: (213) 486-0168
(Area Code) (Area code)
E-Mail Address: Grants@lapd.lacity.org

6. The **Chair** of the **governing body** of the recipient: (Provide contact information other than that of the recipient)

Name: Eric Garcetti Address: 200 N. Spring Street
Title: President, Los Angeles City Council City: Los Angeles Zip: 90012
Telephone #: (213) 473-7013 Fax #: (213) 613-0819
(Area Code) (Area code)
E-Mail Address: Garcetti@council.lacity.org

SIGNATURE AUTHORIZATION

Grant Award #: _____

Grant Recipient: CITY OF LOS ANGELES

Implementing Agency: Los Angeles Police Department

***The Project Director and Financial Officer are REQUIRED to sign this form.**

*Project Director: Steven Ruiz

Signature: 

Date: 10/22/10

*Financial Officer: Gerald L. Chaleff

Signature: 

Date: 11/3/10

The following persons are authorized to sign for the
Project Director

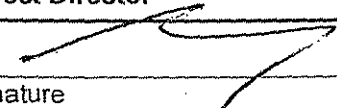
Signature

Edward J. Prokop

Name

Signature

Joseph R. Viguera

Name

Signature

Name

Signature

Name

Signature

Name

The following persons are authorized to sign for the
Financial Officer

Signature

Laura Luna

Name

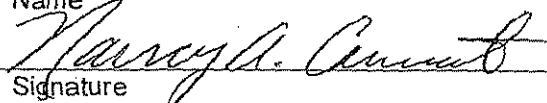
Signature

Nancy A. Cammarata

Name

Signature

Name

Signature

Name

Signature

Name

IV. Lobbying – (Recipient Handbook Section 2154)

CalEMA grant funds, grant property, or grant funded positions shall not be used for any lobbying activities, including, but not limited to, being paid by or on behalf of the undersigned, to any person for influencing or attempting to influence an officer or employee of any agency, a Member of Congress, an officer or employee of Congress, or an employee of a Member of Congress in connection with the making of any federal grant, the entering into of any cooperative agreement, and the extension, continuation, renewal, amendment, or modification of any federal grant or cooperative agreement.

V. Debarment and Suspension – (Recipient Handbook Section 2155)

(This applies to federally funded grants only.)

CalEMA-funded projects must certify that it and its principals are not presently debarred, suspended, proposed for debarment, declared ineligible, sentenced to a denial of federal benefits by a state or federal court, or voluntarily excluded from covered transactions by any federal department of agency.

VI. Proof of Authority from City Council/Governing Board

The above-named organization (applicant) accepts responsibility for and will comply with the requirement to obtain written authorization from the city council/governing board in support of this program. The applicant agrees to provide all matching funds required for said project (including any amendment thereof) under the Program and the funding terms and conditions of CalEMA, and that any cash match will be appropriated as required. It is agreed that any liability arising out of the performance of this Grant Award Agreement, including civil court actions for damages, shall be the responsibility of the grant recipient and the authorizing agency. The State of California and CalEMA disclaim responsibility of any such liability. Furthermore, it is also agreed that grant funds received from CalEMA shall not be used to supplant expenditures controlled by the city council/governing board.

The applicant is required to obtain written authorization from the city council/governing board that the official executing this agreement is, in fact, authorized to do so. The applicant is also required to maintain said written authorization on file and readily available upon demand.

VII. Filing Costs for Criminal Charges and Protection

Its laws, policies, and practices do not require, in connection with the prosecution of any misdemeanor or felony domestic violence offense, or in connection with the filing, issuance, registration, or service of a protection order, or a petition for a protection order, to protect a victim of domestic violence, stalking, or sexual assault, that the victim bear the costs associated with the filing of criminal charges against the offender, or the costs associated with the filing, issuance, registration, or service of a warrant, protection order, petition for a protection order, or witness subpoena, whether issued inside or outside the state, tribal, or local jurisdiction.

VIII. Forensic Medical Examination Payment Requirement for Victims of Sexual Assault

The state or territory, Indian tribal government, unit of local government, or another governmental entity incurs the full out-of-pocket cost of forensic medical exams for victims of sexual assault.

The state or territory, Indian tribal government, unit of local government, or another governmental entity does not require a victim of sexual assault to participate in the criminal justice system or cooperate with

Applicant: City of Los Angeles/LAPD Grant Number: _____

Project Narrative

Problem Statement

The City of Los Angeles (City) is the “gang capital” of the nation. There are more than 450 diverse gangs throughout the City and an association of approximately 80,000 gang members. Despite historically low gang crime rates and crime rates overall, certain areas of the City still experience unacceptable levels of gang violence and crime. To prevent escalation of these violent crimes in these areas, the City needs a specialized strategy that maximizes both enforcement resources as well as prevention and intervention resources, through coordination and improved communication, particularly, with incidents involving gang related criminal activity.

Rampart Division, the densest populated geographic area in the City, and MacArthur Park are known for its presence of numerous gangs and extremely violent criminal gang activity. Within the less than seven square miles of Rampart Division, there are 23 documented violent turf gangs. The close proximity of these gangs has proven to lead to violence without any pattern. In Rampart Division, the two most notorious and publicized gangs throughout the nation are the Mara Salvatrucha (MS) and 18th Street gangs. Both gangs were established in Rampart Division.

In 2009 and 2010, the Los Angeles Police Department (LAPD) ranked MS and 18th Street as the second and third top targeted gangs in Los Angeles due to their violent criminal activity. There were over 300 violent crimes associated with MS and over 250 violent crimes associated with 18th Street. The LAPD also ranked MS number one in assaults on police officers. In Los Angeles County (County), 18th Street is considered the largest gang with estimations of 25,000 members and an additional 30,000 gang members worldwide. There are numerous cliques throughout the County, the largest of them being located within Rampart Division.

Applicant: City of Los Angeles/LAPD Grant Number: _____

Rampart Division has had a steady decline in these violent crimes through continuous cooperation of numerous outside agencies, the Rampart Community and the diligent work of the Rampart police officers. The Project Safe Neighborhoods Grant would assist in the continued reduction of violent crimes in the Rampart Area. In 2009, Rampart Division had documented 1,346 violent crimes, which included homicide, rape, robbery and aggravated assaults. There were 65 shooting victims and 122 documented shots fired incidents. Rampart had 188 firearm seizures and 112 of them related to weapons arrests. In 2010, through June, Rampart Division has had 619 Violent Crimes, including 37 shooting victims and 90 shots fired incidents. In addition, Rampart had 97 firearm seizures and 75 of them related to weapons arrests.

Furthermore, Rampart Division has been concerned with the early release of Non-Revocable Parolees (NRP) within the community, as well as changes to parole and rehabilitation programs. The anticipation and consequences of the early release of these parolees to an already volatile and gang infested community has prompted Rampart Division, along with its community partners, to launch the Community Re-Entry Outreach Program (CROP) in November 2009.

Plan

The Rampart collaborative, consisting of Rampart Law Enforcement Supervisors working collectively with intervention and prevention programs, identified a need for additional strategies and enforcement to assist in the re-entry of NRP and to assist parolees released in the Rampart Community.

The overall intent of CROP is to:

- Identify prison inmates to be released into the Rampart Community.
- Conduct early outreach to triage their needs.

Applicant: City of Los Angeles/LAPD Grant Number: _____

- Attempt to place them into programs that will support their needs as they re-enter society.
- Provide stable conditions of NRPs re-entering the community from prison.
- Facilitate growth into being productive community members.

Rather than allow NRPs to re-enter the community and be susceptible to the surrounding gang and criminal element, CROP identifies persons to be released and conducts early outreach to triage their needs to place them into programs that will support their needs.

Current members of the Rampart CROP collective consist of the representatives from the Offices of the Mayor, City Attorney, District Attorney, Probation, Aztecs Rising, El Centro del Pueblo, People Assisting the Homeless (PATH), Walden House, Catholic Charities and California Parole. CROP is a new pilot program that community members are also showing an interest in joining. CROP utilizes outreach, triage outsource and alternatives as the foundations of the program. Since gang intervention and prevention go hand in hand with re-entry, existing gang prevention providers are essential to this new program.

Once a month the joint outreach team consisting of Rampart gang Detectives, Aztecs Rising, and California Parole attend the Mid City Parole Orientation Meeting. At this meeting, the team performs the following: 1) interviews persons just released from prison, 2) identifies persons scheduled to be released from prison the next month, 3) conducts a screen to assess needs and offer assistance to persons just released, and 4) attempts to contact and assess the needs of persons scheduled to be released. The Program is voluntary and those persons refusing help from the community are documented for possible future reference.

The outreach joint team reports to the Rampart CROP collective the week following the Mid City Parole Orientation Meeting. This meeting is once-a-month and the

Applicant: City of Los Angeles/LAPD Grant Number: _____

team briefs the collective on each person to be released and identifies any needs.

CROP attempts to identify an organization willing to provide resources, such as housing, job training, or drug rehabilitation. A briefing is also conducted for the individuals who refuse to accept assistance in order to commence closer law enforcement monitoring.

The Rampart Violent Crime Impact Team (VCIT) recently launched the "Parolee Index System," which tracks parolees within the Rampart Division. The Parolee Index System is an excel spreadsheet that tracks parolees based on name, descriptors, Criminal Investigation and Identification (CII) number, California Department of Corrections and Rehabilitation (CDC) number, home address and Reporting District (RD) and parole offense. Armed with this information we can track and monitor crimes that happen in that particular area and check it against the parolees who reside in that area for enforcement action. The grant award will greatly assist Rampart Gang Detectives and uniformed gang officers with enforcement by allowing officers to conduct more parole and probation compliance checks and monitor repeat offenders in the Rampart area.

The Community Law Enforcement and Recovery (CLEAR) Program specifies and targets the gangs around MacArthur Park. The Rampart Special Problems Unit (SPU) and the Career Criminal Unit will work with CLEAR to enhance the quality of life issues within the CLEAR zone. The Project Safe Neighborhood Grant funding will further ensure the safety of the community, specifically around MacArthur Park.

Rampart's enforcement collaborative is to reduce the temptation by the surrounding gangs to enjoin the parolee in criminal activity. Rampart will document the guns, gang members, parolees, and arrests in the immediate area of the person requiring assistance. In addition, Rampart will document the decrease in crime in the area where the CROP collective has operated. Those who fall out of the program will be de-briefed. This de-brief will ascertain if the failure was due to the program, certain

Applicant: City of Los Angeles/LAPD Grant Number: _____

elements of the Program and/or the individuals' requiring the assistance own lack of initiative. Each month an evaluation will take place of each individual who is participating to determine their status. In addition, the Rampart Division Gang Impact Team will: track all individuals (parolees) who are released in the Rampart area; track the briefing sessions; identify and track those who refuse assistance; identify and track the individuals that request assistance; maintain data for those who are referred for specific assistance, and their successes/failures. Based on the culmination of tracked and maintained data, a determination will be made if there is a need to make any improvements to the program, or if necessary, change the strategy to assist the participating individuals to make a successful transition to the community.

During the project performance period, the LAPD will adhere to the following objectives and activities issued by the Department of Justice-Bureau of Justice

Assistance:

OBJECTIVE 1:

To create safer neighborhoods by reducing gun violence, gun crime and sustaining that reduction.

Performance Measures –

- Percentage of targeted PSN sites reporting a reduction over the previous year in the number of homicides with a firearm.
- Percentage of targeted PSN sites reporting a reduction in the number of combined homicides, aggravated assaults, and robberies committed with a firearm.

The LAPD will report on the following data quarterly:

- Number of homicides with a firearm experienced during the current reporting period within the targeted PSN site.

Applicant: City of Los Angeles/LAPD

Grant Number: _____

- Number of combined aggravated assaults, and robberies that are committed with a firearm during the current reporting period within the targeted PSN site.

OBJECTIVE 2:

Reduce the occurrence of violent gang-related incidents through both reactive and proactive efforts supported by enforcement planning coordinated with federal, state, and local law enforcement and informed by data and real-time intelligence.

Performance Measures –

- The percentage of combined homicides, aggravated assaults, and robberies that are gang-related.

The LAPD will report on the following data quarterly for this objective:

- The total number of gang-related homicides that occurred during the current reporting period.
- The total number of gang-related aggravated assaults that occurred during the current reporting period.
- The total number of gang-related robberies that occurred during the current reporting period.
- The total number (gang-related and non gang-related) of homicides, aggravated assaults and robberies that occurred during the current reporting period.

OBJECTIVE 3:

Reduce the occurrence of youth gang-related incidents and increase positive outcomes for youth at high risk for gang involvement through targeted, evidenced-based gang prevention.

Applicant: City of Los Angeles/LAPD Grant Number: _____

Performance Measures –

- The percentage of youth completing Program requirements.

The LAPD will report on the following data quarterly for this objective:

- The total number of youth participating in the Program during the current reporting period.
- The total number of youth that completed the Program during the current reporting period.
- The total number of youth that exited the Program during the current reporting period without completing the Program.

CROP provides alternatives to individuals released from prison, the community and law enforcement. For the individuals released from prison it demonstrates that the community is interested in their welfare and willing to help. It offers stability, transition and an alternative to criminality even when state funding for these programs is limited. Ultimately, the individual is given the choice by his own community to either accept help or reject it. For those individuals agreeing to accept help, alternatives to prosecution for minor transgressions will be provided by the City Attorney and District Attorney. For gang members who volunteer to enter the program, assistance from law enforcement and the City Attorney's Office will be provided to remove the person from a gang injunction.

Alternatives to the community and law enforcement are multiplied. For the community CROP offers the opportunity and alternatives to persons re-entering the community in a budget austere environment. For law enforcement it provides alternatives to costly prosecution only models. It also provides a pre-emptive model to

Applicant: City of Los Angeles/LAPD Grant Number: _____

shield the community from increased crime by identifying violent offenders unwilling to reform in order to allow closer and early law enforcement monitoring.

Budget Narrative

**PROJECT SAFE NEIGHBORHOODS PROGRAM
Fiscal Year 2010/2011**

The Los Angeles Police Department (LAPD) budget for the 2010-2011 Project Safe Neighborhoods Grant will be utilized by the Department's Rampart Area, Gang Impact Team (GIT). The grant funding will be utilized in conjunction with the Community Re-Entry Outreach Program (CROP) to satisfy four requirements identified by the GIT Officer in Charge as follows:

- 1) Make physical contact with prison inmates that are released within the Rampart Area.
- 2) Conduct gang enforcement roll-backs on inmates that are identified as gang members¹.
- 3) Conduct outreach to prison inmates and provide them with a list of available services once they are released into the Rampart Area.
- 4) Reduce gang crime in the Rampart Area.

Personnel Services

The LAPD will utilize a total of \$42,000 for personnel services. Specifically, the grant will fund overtime for one sworn supervisor, at the rank of either a Lieutenant I, Sergeant I or II, and six Police Officers III or II, who are assigned to the Rampart Area Gang Impact Team. They will be assigned to details whose primary responsibility will be to perform the four areas outlined above. The grant will fund approximately 23 details. Each detail will include one supervisor calculated at \$80 x 4 hours, totaling \$320, and six police officers calculated at \$63 x 4 hours, totaling \$1,512. The total cost of each detail is \$1,832. The total cost associated with the Project Safe Neighborhoods Grant funding for the Department to implement the intervention/suppression strategy is \$42,000.

¹ Gang members that are on parole or probation and have search conditions. Gang Enforcement Detail (GED) will verify the search conditions and conduct roll-backs to the gang members residence in search of illegal activity.

BUDGET CATEGORY AND LINE ITEM DETAIL

A. Personal Services – Salaries/Employee Benefits	COST
<p><u>CROP GIT Details</u></p> <p>Overtime Per Detail:</p> <p>1-Supervisor (Lieutenant I/Sergeant I or II) @ \$80/hr. x 4/hrs. = \$320</p> <p>6-Police Officers (I or II) @ \$63/hr x 4/hrs. = \$1,512 (\$320 + \$1,512 = \$1,832)</p> <p>22.926 Details x \$1,832 = \$42,000</p>	<p align="right">\$42,000</p>
TOTAL	\$42,000

BUDGET CATEGORY AND LINE ITEM DETAIL

B. Operating Expenses	COST
TOTAL	\$0

BUDGET CATEGORY AND LINE ITEM DETAIL

C. Equipment	COST
TOTAL	\$0.00
Total Project Cost*	\$42,000
<i>*Same as Block 10G on the Grant Award Face Sheet</i>	

PROJECT SUMMARY

1. GRANT AWARD NO.		3. GRANT PERIOD	
2. PROJECT TITLE <u>Community Re-Entry Outreach Program (CROP)</u>		<u>10/1/2010</u> to <u>09/30/2011</u>	
4. APPLICANT		5. GRANT AMOUNT (this is the same amount as 10G of the Grant Award Face Sheet)	
Name: <u>City of Los Angeles, Los Angeles Police Department</u>	Phone: <u>(213) 486-0380</u>	\$42,000	
Address: <u>100 W. First St., Ste. 1061</u>	Fax #: <u>(213) 486-5727</u>		
City: <u>Los Angeles</u>	Zip: <u>90012</u>		
6. IMPLEMENTING AGENCY			
Name: <u>Los Angeles Police Department</u>	Phone: <u>(213)486-0380</u>	Fax #: <u>(213) 486-5727</u>	
Address: <u>100 W. First St., Suite 842</u>	City: <u>Los Angeles</u>	Zip: <u>90012</u>	
7. PROGRAM DESCRIPTION			
<p>The City of Los Angeles (City) is the "gang capital" of the nation and with more than 450 diverse gangs throughout the City and an association of approximately 80,000 gang members; the City has been entrenched with gang violence. Despite historically low gang crime rates and crime rates overall, certain areas of the City still experience unacceptable levels of gang violence and crime. To prevent escalation of these violent crimes in these areas, the City needs a specialized strategy that maximizes both enforcement resources as well as prevention and intervention resources through coordination and improved communication, particularly with incidents involving gang related criminal activity. Rampart launched the Community Re-Entry Outreach Program (CROP) in 2009.</p>			
8. PROBLEM STATEMENT			
<p>The Rampart collaborative, consisting of Rampart Law Enforcement Supervisors working collectively with intervention and prevention programs, identified a need for additional strategies and enforcement to assist in the re-entry of Non-Revocable Parolee (NRP) and to assist parolees released in the Rampart community.</p>			
<p>The overall intent of CROP is to:</p>			
<ul style="list-style-type: none">• Identify prison inmates to be released into the Rampart community.• Conduct early outreach to triage their needs.• Attempt to place them into programs that will support their needs as they re-enter society.• Provide stable conditions of NRPs re-entering the community from prison.• Facilitate growth into being productive community members.			
<p>Rather than allow NRPs to re-enter the community and be susceptible to the gang and criminal element surrounding them, CROP identifies persons to be released and conducts early outreach to triage their needs and attempt to place them into programs that will support their needs.</p>			

9. OBJECTIVES

CROP provides alternatives to individuals released from prison, the community and law enforcement. For the individuals released from prison it demonstrates that the community is interested in their welfare and willing to help. It offers stability, transition and an alternative to criminality even when state funding for these programs is limited. Ultimately, the individual is given the choice by his own community to either accept help or reject it. For those individuals agreeing to accept help, alternatives to prosecution for minor transgressions will be provided by the City Attorney and District Attorney. For gang members who volunteer to enter the program, assistance from law enforcement and the City Attorney's Office will be provided to remove the person from a gang injunction.

Alternatives to the community and law enforcement are multiplied. For the community CROP offers the opportunity and alternatives to persons re-entering the community in a budget austere environment. For law enforcement it provides alternatives to costly prosecution only models. It also provides a pre-emptive model to shield the community from increased crime by identifying violent offenders unwilling to reform in order to allow closer and early law enforcement monitoring. Additionally, for those persons who refuse assistance, their refusal to accept assistance will be maintained on file. This refusal will then be submitted to the court to ensure criminal filing, refute necessity defenses and increase prison sentences.

Rampart's enforcement collaborative is to reduce the temptation by the surrounding gangs to enjoin the parolee in criminal activity. Rampart will document the guns, gang members, parolees, and arrests in the immediate area of the person requiring assistance. In addition, Rampart will document the decrease in crime in the area where the CROP collective has operated.

Those who fall out of the program will be de-briefed. This de-brief will ascertain if the failure was due to the program, certain elements of the program and/or the individual's requiring the assistance own lack of initiative.

In addition, the Rampart Division Gang Impact Team will: track all individuals (parolees) who are released in the Rampart Area; track the briefing sessions; identify and track those who refuse assistance; identify and track the individuals that request assistance; maintain data for those who are referred for specific assistance, and their successes/failures. Based on the culmination of tracked and maintained data, a determination will be made if there is a need to make any improvements to the program, or if necessary, change the strategy to assist the participating individuals to make a successful transition to the community.

10. ACTIVITIES

The Rampart Violent Crime Impact Team (VCIT) recently launched the "Parolee Index System," which tracks parolees within the Rampart Division. The Parolee Index System is an excel spread sheet that tracks parolees based on name, descriptors, Criminal Investigation and Identification (CII) number, California Department of Corrections and Rehabilitation (CDC) number, the home address and Reporting District (RD) of the parolee. Armed with this information we can track and monitor crimes that happen in that particular area and check it against the parolees who reside in that area for enforcement action. The 2010 Project Safe Neighborhoods Program Grant would greatly assist Rampart Gang Detectives and uniformed gang officers with the enforcement side by allowing them to conduct more parole and probation compliance checks and by monitoring repeat offenders in the Rampart area.

The Community Law Enforcement and Recovery (CLEAR) Program specifies and targets the gangs around MacArthur Park. The new vending unit, Special Problems Unit (SPU) is up and running as well as the Career Criminal Unit. CLEAR works with the units to enhance the quality of life issues within the CLEAR zone. The Project Safe Neighborhoods Grant would ensure the safety of the community, specifically around MacArthur Park.

Rampart Division has had a steady decline in violent crimes through continuous cooperation with numerous outside agencies, the Rampart community and the diligent work of the Rampart officers. The Project Safe Neighborhoods Grant would assist in the continued reduction of violent crimes in the Rampart area. In 2009, Rampart Division documented 1,346 violent crimes, which include homicides, rapes, robberies and aggravated assaults. With that, there were 65 shooting victims and 122 documented shots fired. Rampart had 188 firearm seizures and 112 of them related to weapons arrests. In 2010, through June, Rampart Division has had 619 violent crimes. There has been 37 shooting victims and ninety shots fired. Rampart had 97 firearm seizures—75 of those related to weapons arrests.

6. NUMBER OF CLIENTS
(if applicable)

13. PROJECT BUDGET				
(these are the same amounts as on Budget Pages)				
	Personal Services	Operating Expenses	Equipment	TOTAL
	\$42,000	0	0	\$42,000
	0	0	0	0
	0	0	0	0
	0	0	0	0
	0	0	0	0
	0	0	0	0
Totals:	\$42,000	0	0	\$42,000

RAMPART

AREA COMMANDING OFFICER
CAPT III Steven A. Ruiz

RECORDS UNIT
OIC - PCP Martha Castaneda

COMPLAINT UNIT
OIC - SGT I Justin Mudgett

TRAINING UNIT
OIC - SGT. II Allan Seeget
PI / FTO COORDINATOR
PO II Brian Koren

VICE UNIT
OIC - SGT. II Ryan Schatz

COMMUNITY RELATIONS OFFICE (CRO)
OIC - SGT II Mike Seguin
SENIOR LEAD OFFICERS (SLO)
RESERVE COORDINATOR
Juvenile Intervention Prevention Program Coordinator (JIPP)

GANG IMPACT TEAM (GIT)
OIC - LT. I Ed Prokop (Acting)

GANG ENFORCEMENT DETAIL (GED)
DIII Rick Ramos

NARCOTICS ENFORCEMENT DETAIL
DIII Mike Kearney

DETECTIVE DIVISION
OIC - LT. II Joe Losorelli

WATCH COMMANDER
LT. I Darryl Ito

DETECTIVE ADJUTANT
MA II Karrie Vong
SECRETARY
SCT Doug Endo

HOMICIDE
DIII John Motto

FILING TEAM
DII Lilia Velasco

ROBBERY
DII Joe Barragan

MAC/SEX
DIII Sofie Toledo

PROPERTY DISPO
PSR Deborah Deveres

BURGLARY
DIII Mario Mota

CAPS
DIII Vacant

AUTOS
DIII Tim Blake

PATROL C/O
CAPT I Ray Maltez

PATROL ADJUTANT
MA II Cristy McCaleb
PATROL SECRETARY
SCT Vacant

WATCH 2
WC: LT I Wes Buhrmester

WATCH 3
WC: LT I Cory Palka

WATCH 7
WC: SGT II Robert Bishop

SUBPOENA CONTROL OFFICER
PO II Lissa Mora

AREA ADJUTANT
PO III Gustavo Marroquin
AREA SECRETARY
Secretary Mariana Vasquez

SICK & IOD
P-2 Maria Illingworth

CONSENT DECREE
SGT I Herb Chang

TIMEKEEPER
PSR Ivy Gutierrez

OVERTIME
SCT Imelda Nuno-Lopez

RAMPART GIT ORGANIZATION CHART DP -13, 2010

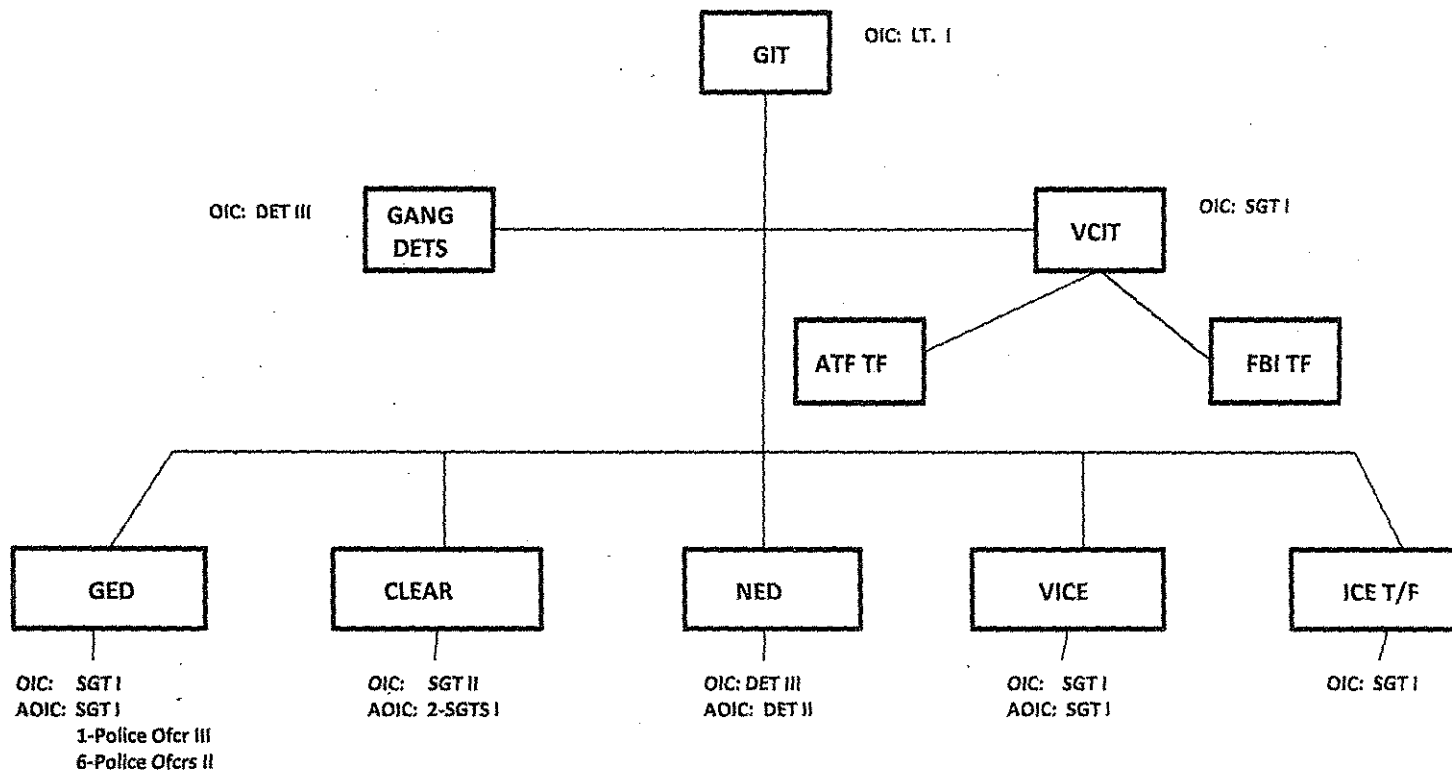

**MEMORANDUM OF UNDERSTANDING
THE
LOS ANGELES POLICE DEPARTMENT'S
COMMUNITY RE-ENTRY OUTREACH PROGRAM (CROP)**

This Memorandum of Understanding ("MOU") is made and entered into by and among the Los Angeles Police Department ("LAPD"), Aztecs Rising, a California non-profit corporation, El Centro del Pueblo, a California non-profit corporation, People Assisting The Homeless (PATH), a California non-profit corporation, Walden House, a California non-profit corporation, and Catholic Charities, a California non-profit corporation. This MOU outlines a cooperative effort to assist parolees in re-entry into the community and provide gang intervention.

I. Purpose of MOU

This MOU establishes and delineates the mission of the LAPD's CROP in addressing the complex problem of gang intervention prevention and to assist in the re-entry of non-revocable parolees in the greater Los Angeles Metropolitan Area, which includes the City and County of Los Angeles. Nothing in this MOU shall be construed as encroaching upon the sovereign rights, privileges, and immunities of the LAPD by any of the parties hereto, in the conduct of inherently Municipal, State or Federal government operations. Nothing in this MOU is intended to conflict with current law, regulation, or the policies and directives of the City of Los Angeles. If the terms and conditions of this MOU is inconsistent with such authorities, the parties hereto agree to address and resolve the inconsistency in a timely and legally appropriate manner, unless the matter is incapable of timely resolution, in which case the inconsistent term shall be deemed invalid, but the remaining terms and conditions of this MOU shall in remain in full force and effect. This MOU, in and of itself, does not result in the commitment, obligation, or transfer of funds or other financial obligations between the parties hereto. Prior to the disbursement of any grant funds given to the LAPD to fund the operations of any of the parties hereto in connection with the project set forth in this MOU, such party shall enter into a contract with the City of Los Angeles ("City") setting forth the services to be provided by such party and the assurances and obligations of the parties with respect to the use of such grant funds so disbursed.

II. Mission of the CROP

The mission of CROP is to provide alternatives to individuals released from prison, the community, and law enforcement. For the individuals released from prison it demonstrates that the community is interested in their welfare and willing to help. It offers stability, transition and an alternative to criminality even when state funding for these programs is limited. Ultimately, the individual is given the choice by his own community to either accept help or reject it. For those individuals agreeing to accept help, alternatives to prosecution for minor transgressions will be provided by the City

Memorandum of Understanding
Community Re-entry Outreach Program (CROP)

Attorney and District Attorney. For gang members who volunteer to enter the program, assistance from law enforcement and the City Attorney's Office will be provided to remove the person from a gang injunction.

Alternatives to the community and law enforcement are multiplied. For the community CROP offers the opportunity and alternatives to persons re-entering the community in a budget austere environment. For law enforcement it provides alternatives to costly prosecution only models. It also provides a pre-emptive model to shield the community from increased crime by identifying violent offenders unwilling to reform in order to allow closer and early law enforcement monitoring.

III. Composition of the CROP

A. Participation

Current members of the Rampart CROP collective consist of the representatives from the Offices of the Mayor, City Attorney, and District Attorney, and Aztecs Rising, El Centro del Pueblo, People Assisting the Homeless (PATH), Walden House, Catholic Charities and California Parole.

B. Direction of CROP

Responsibility for the overall policy and direction of CROP shall rest with the LAPD. The LAPD's Rampart Division will provide a staff member to serve as Program Manager. The Program Manager will coordinate with the community partners (non-profit organizations) and the LAPD on matters of mutual concern relating to policy and direction of the program.

C. Supervision of CROP

Day-to-day supervision of CROP activities by its members at participating agencies is the responsibility of the respective agency heads or their designees.

D. Personnel

Decisions to dedicate and control personnel assigned to CROP shall remain with the participating agency heads or their designees.

E. Adding Participating Agencies

Proposals to add new participating agencies to CROP may be made at any time by

Memorandum of Understanding
Community Re-entry Outreach Program (CROP)

written notification to the Program Manager of CROP. Consideration of this matter will be included on the agenda for the next regularly scheduled CROP meeting.

IV. Operation of Enhanced Crisis Response/CROP

A. LAPD Responsibilities

As a collaborative partner in CROP, the LAPD will:

1. Continue to provide a staff member to act as Program Manager, under the direction of the Commanding Officer, Rampart Division. The percentage of dedicated time will be contingent upon the grant award amount LAPD receives for this program.
2. Maintain a database for the collection and analysis of parolee and crime data as required by CalEMA.
3. Coordinate and conduct monthly meetings for CROP team members.
4. Collect and report data that measures CROP's results. These reports shall include but not be limited to quarterly progress reports, the final progress report, and financial reports. All required reports shall be submitted to CalEMA.

B. Non-Profit Organizations Responsibilities

As a collaborative partner in CROP, the Non-Profit Organizations will:

1. Provide services to parolees, such as housing, job training, or drug rehabilitation.
2. Collaborate with participating agencies, as well as other local and federal governmental agencies and non-governmental agencies, working to provide outreach, gang prevention and intervention.
3. Participate in monthly CROP meetings.
4. Respond to requests for information for data relevant to program goals and results from participating agencies.

V. Non-Responsibility

Individual agency members of CROP will not be responsible or liable for acts performed by personnel of other member agencies or other government or nongovernmental agencies in furtherance of or in relation to CROP objectives or activities during the

Memorandum of Understanding
Community Re-entry Outreach Program (CROP)

duration of this MOU. Each individual agency member of CROP agrees that it retains responsibility for the actions of its personnel in connection with CROP activities.

VI. Duration

The term of this MOU is for the duration of CROP. This MOU will enter into effect on the date of the last signature of the agency officials authorized to bind the agencies.

This MOU may be modified at any time by written consent of all involved agencies. Modifications to this MOU shall have no effect unless such modifications are in writing and signed by an authorized representative of the parties hereto.

Any participating agency may withdraw from CROP as any time by written notification to the Program Manager of CROP. Any such withdrawal shall be effective 30 days after delivery of written notification of withdrawal to the Program Manager.

We, the undersigned, have read and agree with this MOU. We are committed to work together to achieve the stated objectives of the proposed project.

CHARLIE BECK
Chief of Police
Los Angeles Police Department

Date _____

ENRIQUE HURTADO
Aztecs Rising

Date _____

ROBERT AGUAYO
El Centro del Pueblo

Date _____

CARLOS GONZALEZ
People Assisting the Homeless

Date _____

Memorandum of Understanding
Community Re-entry Outreach Program (CROP)

MICHAEL BRENNER
Walden House

Date _____

MIKE CONNER
Dream Center/Catholic Charities

Date _____

OTHER FUNDING SOURCES

Complete this form to report the total funds available to support the activities related to accomplishing the goals and objectives of the Grant Award Agreement. In the "Grant Funds" column, report the CalEMA funds requested by category. In the "Other Funds" column, report all other funds available to support the project by category and then calculate the totals by category in the "Program Total" column. Total each column to arrive at the total program funds available.

OTHER FUNDING SOURCES			
(Enter numbers without \$ or decimal points.)			
BUDGET CATEGORY	GRANT FUNDS <i>(Use only the grant funds identified in the preceding budget pages.)</i>	OTHER FUNDS	PROGRAM TOTAL
Personal Services	42,000	13,360	\$55,360
Operating Expenses			\$0
Equipment			\$0
TOTAL	\$42,000	\$13,360	\$55,360

This form does not become part of the grant award.

PRIOR, CURRENT AND PROPOSED CalEMA FUNDING

List all currently funded CalEMA projects and all CalEMA grants awarded to the applicant during the last five fiscal years. Include the fiscal year of operation, the grant number and the amount of CalEMA funding. For current and proposed grants that include positions funded by more than one CalEMA grant, list these personnel by title and the percentage of the position funded by CalEMA. The percentage of funding must not exceed 100 percent for any one individual.

Example				
FISCAL YEAR	GRANT NUMBER	GRANT AMOUNT	PERSONNEL BY TITLE	PERCENTAGE PAID BY CalEMA
2005-06	DC05160010	\$50,000	Project Director	25%
2005-06	CE05089504	\$67,000	Project Director	25%
2005-06	MS05040550	\$68,000	Project Director	50%

PRIOR, CURRENT AND PROPOSED CalEMA FUNDING				
FISCAL YEAR	GRANT NUMBER	GRANT AMOUNT	PERSONNEL BY TITLE	% of CalEMA FUNDING
2006-07	AG061B7250	\$131,708	Detective II	88.9%
2007-08	AG07B27250	\$118,545	Crime & Intel Analyst	100%
2005-06	CQ05057250	\$170,443	N/A	N/A
2006	CQ0507250 (subgrant)	\$106,474	N/A	N/A
2007	CQ07067250	\$113,107	N/A	N/A
2007	CQ08077250	\$105,841	N/A	N/A
2008	CQ08077250	\$181,032	N/A	N/A
2007	IC07017250	\$125,000	Detective II	50%
2008	IC07017250	\$125,000	Detective II	50%

PRIOR, CURRENT AND PROPOSED CalEMA FUNDING

List all currently funded CalEMA projects and all CalEMA grants awarded to the applicant during the last five fiscal years. Include the fiscal year of operation, the grant number and the amount of CalEMA funding. For current and proposed grants that include positions funded by more than one CalEMA grant, list these personnel by title and the percentage of the position funded by CalEMA. The percentage of funding must not exceed 100 percent for any one individual.

Example				
FISCAL YEAR	GRANT NUMBER	GRANT AMOUNT	PERSONNEL BY TITLE	PERCENTAGE PAID BY CalEMA
2005-06	DC05160010	\$50,000	Project Director	25%
2005-06	CE05089504	\$67,000	Project Director	25%
2005-06	MS05040550	\$68,000	Project Director	50%

PRIOR, CURRENT AND PROPOSED CalEMA FUNDING				
FISCAL YEAR	GRANT NUMBER	GRANT AMOUNT	PERSONNEL BY TITLE	% OF CalEMA FUNDING
2009	IC07017250	\$125,000	Detective II	50%
2010	IC (application)	\$125,000	Detective II	50%
2006	LE07057250	\$83,219	N/A	N/A
2006	LE07057250	\$41,610	N/A	N/A
2009	LE08017250	\$200,000	Det III/Det II/Advocate	30%/23%/100%
2010	LE09027250	\$200,000	Det III/Det II/Advocate	31%/24%/100%
2011	LE10037250	\$240,279	Det III/Det II/Advocate	31%/24%/100%
2005	US05P27250	\$149,035	Detective II	100%
2007	US07P37250	\$144,980	Detective II	100%

PRIOR, CURRENT AND PROPOSED CalEMA FUNDING

List all currently funded CalEMA projects and all CalEMA grants awarded to the applicant during the last five fiscal years. Include the fiscal year of operation, the grant number and the amount of CalEMA funding. For current and proposed grants that include positions funded by more than one CalEMA grant, list these personnel by title and the percentage of the position funded by CalEMA. The percentage of funding must not exceed 100 percent for any one individual.

Example				
FISCAL YEAR	GRANT NUMBER	GRANT AMOUNT	PERSONNEL BY TITLE	PERCENTAGE PAID BY CalEMA
2005-06	DC05160010	\$50,000	Project Director	25%
2005-06	CE05089504	\$67,000	Project Director	25%
2005-06	MS05040550	\$68,000	Project Director	50%

PRIOR, CURRENT AND PROPOSED CalEMA FUNDING				
FISCAL YEAR	GRANT NUMBER	GRANT AMOUNT	PERSONNEL BY TITLE	% OF CalEMA FUNDING
2008	US08P47250	\$50,000	Detective II	40%/100%
2009	US09P56250	\$60,000	N/A	N/A
2010	US10 (application)	\$42,000	N/A	N/A
2009	ZH09017250	\$375,000	Mgmt Analyst II/CAST Case Worker	70%/40%

PROJECT SERVICE AREA INFORMATION

1. COUNTY OR COUNTIES SERVED: Enter the name(s) of the county or counties served by the project. Put an asterisk where the project's principal office is located.

Los Angeles County

2. U.S. CONGRESSIONAL DISTRICT(S): Enter the number(s) of the U.S. Congressional District(s) which the project serves. Put an asterisk for the district where the project's principal office is located.

31 and *34.

3. STATE ASSEMBLY DISTRICT(S): Enter the number(s) of the State Assembly District(s) which the project serves. Put an asterisk for the district where the project's principal office is located.

*45 and 48.

4. STATE SENATE DISTRICT(S): Enter the number(s) of the State Senate District(s) that the project serves. Put an asterisk for the district where the project's principal office is located.

*22.

5. POPULATION OF SERVICE AREA: Enter the total population of the area served by the project.

The Los Angeles Police Department serves approximately 3.8 million residents throughout the City (2006 U.S. Census Bureau estimate).

FEDERAL GRANTS FUNDING LOG

List all federal grant funds awarded to the applicant during the current year. Include the fiscal year of operation, funding agency and the amount of funding.

If your agency receives no federal grant funds check this box:

	FISCAL YEAR	FUNDING AGENCY	GRANT AMOUNT
1	10-11	Dept of Justice	\$250,000
2	10-11	Dept of Justice	\$16,285,650
3	09-10	Dept of Justice	\$246,549
4	10-11	Dept of Justice	\$1,246,257
5	10-11	Dept of Justice	\$400,000
6	10-11	Dept of Justice/NIJ	\$150,747
7	09-10	Dept of Justice/NIJ	\$1,023,151
8	10-11	Dept of Justice/NIJ	\$1,130,868
9	10-11	Dept of Justice/BJA	\$170,000
10	09-10	Dept of Justice/BJA	\$499,959
		Federal Grant Total:	\$21,403,181

FEDERAL GRANTS FUNDING LOG

List all federal grant funds awarded to the applicant during the current year. Include the fiscal year of operation, funding agency and the amount of funding.

If your agency receives no federal grant funds check this box:

	FISCAL YEAR	FUNDING AGENCY	GRANT AMOUNT
1	09-10	Dept of Justice/OJJDP	\$1,284,887
2	09-10	Dept of Justice/OJJDP	\$1,350,900
3	09-10	CA Office of Traffic Safety	\$67,000
4	09-10	Office of Homeland Security	\$562,090
5	09-10	Department of Homeland Security	\$325,000
6	10-11	CA Emergency Management Agency	\$375,000
7	10-11	CA Emergency Management Agency	\$150,000
8	10-11	CA Emergency Management Agency	\$375,000
9	10-11	CA Emergency Management Agency	\$174,666
10	10-11	CA Office of Traffic Safety	\$1,807,220
		Federal Grant Total:	\$6,471,763

FEDERAL GRANTS FUNDING LOG

List all federal grant funds awarded to the applicant during the current year. Include the fiscal year of operation, funding agency and the amount of funding.

If your agency receives no federal grant funds check this box:

	FISCAL YEAR	FUNDING AGENCY	GRANT AMOUNT
1	09-10	CA Office of Traffic Safety	\$616,591
2	10-11	CA Alcohol and Beverage Control	\$100,000
3	09-10	County of Los Angeles	\$300,000
4	10-11	County of Los Angeles/Probation	\$357,799
5	09-10	DOJ/U.S. Attorney	\$60,000
6			
7			
8			
9			
10			
		Federal Grant Total:	\$1,434,390