

# **Southeast Los Angeles Community Plan Implementation Overlay District (Southeast Los Angeles CPIO District)**

Ordinance No. \_\_\_\_\_

Effective Date \_\_\_\_\_, 2018

## **TABLE OF CONTENTS**

Chapter I	Function of the CPIO District
Chapter II	Corridors Subareas
Chapter III	TOD Subareas
Chapter IV	Industrial Subareas
Chapter V	Residential Subareas
Appendix A	Environmental Standards

## **CHAPTER I – FUNCTION OF THE CPIO DISTRICT**

### **Section I-1. SOUTHEAST LOS ANGELES CPIO DISTRICT AUTHORITY AND BOUNDARIES**

Pursuant to Los Angeles Municipal Code (LAMC) Section 13.14, the City Council establishes the Southeast Los Angeles Community Plan Implementation Overlay District (Southeast Los Angeles CPIO District). The boundaries of the Southeast Los Angeles CPIO District are identical to the boundaries of the Southeast Los Angeles Community Plan Area (Community Plan Area) as adopted on November 22, 2017 (Council File No. 17-1053) and shown on Figure I.

**Figure I**  
**CPIO District Boundaries**

**CORRIDORS SUBAREAS**

- Subarea A - Neighborhood - Serving Corridor
- Subarea B - Parkway Corridor
- Subarea C - General Corridor
- Subarea D - Commercial Corridor

**TOD SUBAREAS**

- Subarea E - TOD Low
- Subarea F - TOD Medium
- Subarea G - TOD High
- Subarea H - TOD Regional

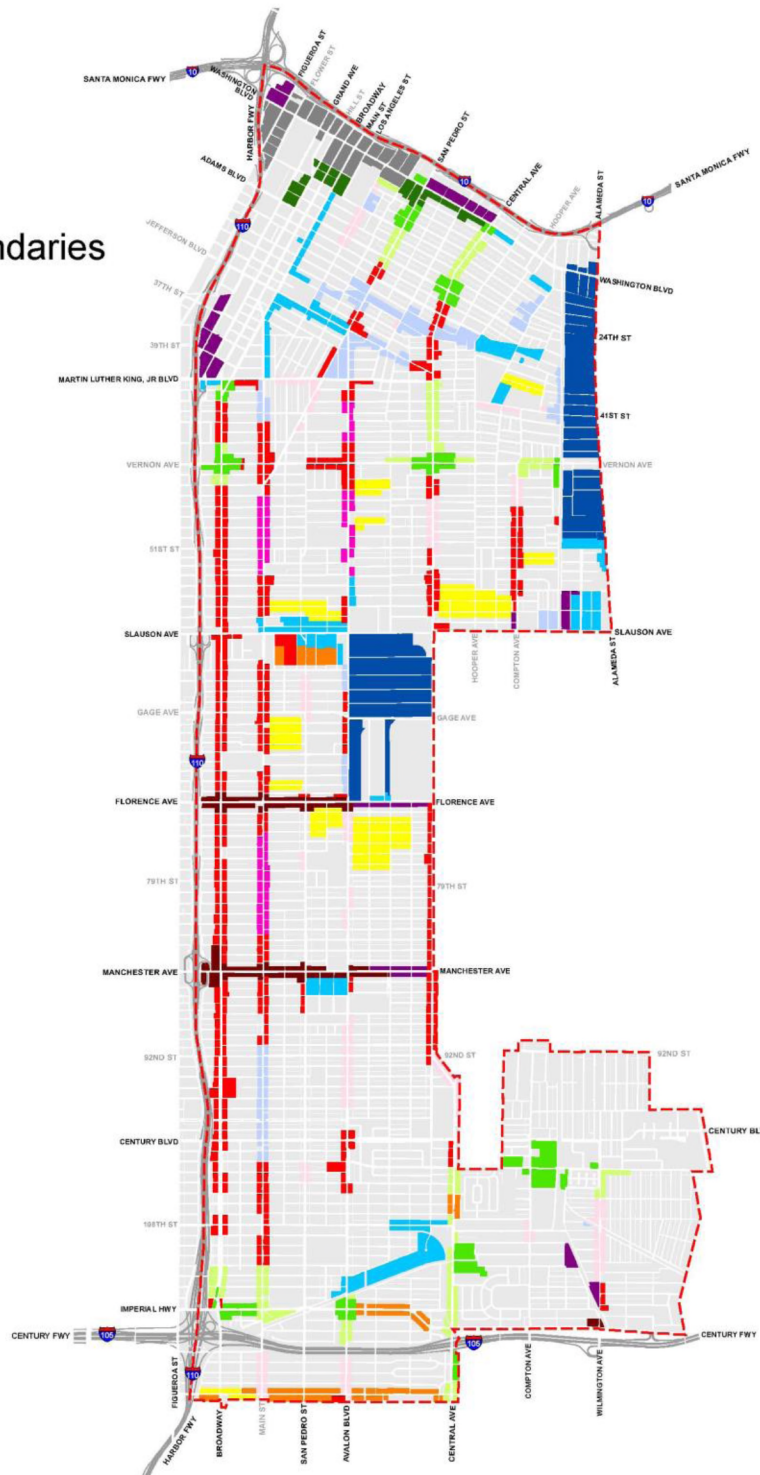
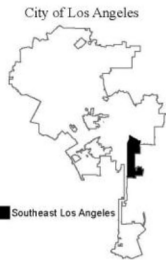
**INDUSTRIAL SUBAREAS**

- Subarea I - Hybrid Limited
- Subarea J - Hybrid
- Subarea K - Compatible Industrial
- Subarea L - Industrial Innovation

**RESIDENTIAL SUBAREAS**

- Subarea M - Legacy Single-Family
- Subarea N - Multi-Family
- Subarea O - Character Residential\*

\*Subarea O is not present in Southeast Los Angeles Community Plan Area  
 Southeast Los Angeles CPA Boundary



## Section I-2. PURPOSES

The purposes of the Southeast Los Angeles CPIO District are as follows:

- A. To implement the goals and policies of the Southeast Los Angeles Community Plan.
- B. To provide supplemental development regulations tailored to the Community Plan Area in order to promote better urban design and to ensure that development enhances the aesthetic character of the community, maintains compatible land uses, and promotes appropriate development scale, intensity, and density.
- C. To create approval processes, including a ministerial administrative clearance process, which enables infill development that will positively impact communities in conformance with these regulations.
- D. To ensure appropriate height, intensity, and transition in order to protect residential neighborhoods from incompatible development and uses along the commercial corridors.
- E. To encourage mixed-income and affordable housing development and minimize potential displacement.
- F. To encourage a diversified range of retail and services that meets the needs of the community.
- G. To improve the health and welfare of the community by limiting certain uses, including those uses that are over-concentrated or that rely on a standardized development typology dominated by excessive automobile orientation.
- H. To foster revitalization of properties along the commercial corridors throughout the Community Plan Area.
- I. To promote and facilitate revitalization of properties in close proximity to major transit stops including the Metro's Expo Line Light Rail Transit (LRT), Blue Line LRT, Green Line LRT and Metro Rapid bus lines.
- J. To discourage non-industrial uses in industrial districts and preserve viable industrial land for the emergence of innovative new clean technology, information technology, and green technology uses.
- K. To encourage the creation of pedestrian-friendly, multi-modal transit centers where jobs, housing, and goods and services are all located within walking distance of transit.
- L. To protect residential uses from adjacent industrial uses through appropriate screening, buffering and use compatibility.
- M. To preserve and protect neighborhood identity, including protecting both designated and eligible non-designated historic resources and distinctive character defining elements of existing development.

- N. To promote the overall health and sustainability of the community that reside, work, and recreate in the Community Plan Area.

### **Section I-3. SUBAREAS**

The Southeast Los Angeles CPIO District contains 15 Subareas as shown on Figure I and as precisely delineated by solid boundary lines on the CPIO District Boundary Maps, attached to the ordinance establishing the Southeast Los Angeles CPIO District. The Subareas are contiguous or non-contiguous parcels characterized by common overarching Community Plan themes, goals, and policies, and are grouped by a common boundary. The Subareas are described below.

#### **Corridors Subareas A, B, C and D**

Corridors Subareas A, B, C and D seek to foster continued investment in the various commercial corridors throughout the Community Plan Area. These Subareas encourage a greater diversity of commercial goods and services for the community by encouraging certain commercial uses, and by providing restrictions for over-concentrated uses through a combination of parking incentives, land use regulations and development standards. Each Subarea contains certain basic development standards to ensure that any new development is compatible with the best attributes of each corridor's urban form.

The four Corridors Subareas are shown on Figures II-1, II-2, II-3 and II-4 and are summarized as follows:

#### **Corridors Subarea A (“Neighborhood-Serving Corridor”)**

The Neighborhood-Serving Corridor Subarea allows for more multi-family housing and a refined range of commercial uses that serve the needs of the surrounding neighborhood. Development standards promote neighborhood activity and facilitate a more pedestrian-oriented environment.

#### **Corridors Subarea B (“Parkway Corridor”)**

The Parkway Corridor Subarea is primarily residential in character and offers incentives for 100 percent residential affordable housing development. Neighborhood-serving commercial uses are encouraged.

#### **Corridors Subarea C (“General Corridor”)**

The General Corridor Subarea allows for a broad range of commercial uses and also allows multi-family residential development.

#### **Corridors Subarea D (“Commercial Corridor”)**

The Commercial Corridor Subarea is applied to major corridors that are auto-oriented, predominantly commercial, and have high vehicle traffic. This Subarea allows for a broad range of commercial uses and requires commercial uses for new development at the ground floor.

## **Transit-Oriented Development (TOD) Subareas E, F, G and H**

TOD Subareas E, F, G and H maximize the presence of fixed light rail transit and Metro Rapid bus lines within the community by providing increased housing and employment opportunities and encouraging quality retail and service amenities. Building upon the community's rich transit infrastructure, these TOD Subareas promote a mix of uses including residential, employment and commercial shopping opportunities within walking distance of light rail transit stations and major bus intersections in order to encourage non-automobile based mobility methods and to reduce regional greenhouse gas emissions. These Subareas encourage increased housing through the use of various tools and programs.

Each TOD Subarea has different levels of density, height and massing tailored to the context of each specific station area, ranging from TOD Low to TOD Regional. These Subareas include a tiered incentive structure that prioritizes mixed-income and 100 percent affordable housing and seeks to ensure replacement units on the project site. Together these incentives are intended to ensure that low-income, transit dependent residents are able to continue to live in these transit centers. Throughout the TOD Subareas, development and design standards provide for well-designed, pedestrian-oriented projects that are appropriate to the scale and context of each specific transit neighborhood. In all TOD Subareas, certain commercial uses are encouraged so as to provide goods and services not adequately provided in the Southeast Los Angeles CPIO District.

The four TOD Subareas are shown in Figures III-1 and III-2 and are summarized as follows:

### **TOD Subarea E (“TOD Low”)**

The TOD Low Subarea is located in close proximity to Metro light rail station or Metro Rapid bus intersections and is characterized by lower intensity development that compliments the surrounding low density and low scale residential neighborhoods.

### **TOD Subarea F (“TOD Medium”)**

The TOD Medium Subarea is located in close proximity to Metro light rail stations or major Metro Rapid bus intersections. This Subarea offers moderate incentives for projects that include affordable housing.

### **TOD Subarea G (“TOD High”)**

The TOD High Subarea is located in close proximity to select Metro light rail stations. This Subarea offers incentives greater than those offered in the TOD Medium subarea for projects that include affordable housing.

### **TOD Subarea H (“TOD Regional”)**

The TOD Regional Subarea allows for higher intensity commercial and mixed-use development that would provide greater housing and employment opportunities along portions of the Figueroa Corridor and the Washington

Boulevard Transit Corridor, and offers the greatest incentives for projects that include affordable housing.

### **Industrial Subareas I, J, K and L**

Industrial Subareas I, J, K and L seek to preserve and revitalize industrial land throughout Southeast Los Angeles. The industrial land in Southeast Los Angeles is a tremendous asset in generating employment and economic investment, and in maintaining a job/housing balance. The Industrial Subareas preserve appropriately located land suitable to accommodate existing, new and relocating industrial firms, including space for small-scale or niche manufacturing and emerging green technologies. These Subareas distinguish between areas that need to be preserved exclusively for industrial uses, areas where increased design sensitivity is needed near residential neighborhoods, and areas where greater flexibility is needed in the range of uses allowed. These Subareas also seek to protect residential and other sensitive uses located adjacent to industrially zoned land from impacts associated with the incompatibility of uses. These Industrial Subareas also encourage a complementary mix of light manufacturing and commercial activity along certain industrial corridors in order to support economic development and jobs generation.

The four Industrial Subareas are shown on Figures IV-1, IV-2 and IV-3 and are summarized as follows:

#### **Industrial Subarea I (“Hybrid Limited Industrial”)**

The Hybrid Limited Industrial Subarea retains a focus on jobs by allowing for a diversity of light industrial and commercial uses. Mixed-use projects may include live/work uses or limited residential with no more than 30 percent of the building’s floor area for residential uses. The Hybrid Limited Industrial Subarea is distinguished from the Hybrid Industrial Subarea by its limits on residential floor area.

#### **Industrial Subarea J (“Hybrid Industrial”)**

The Hybrid Industrial Subarea allows for a mix of uses, including light industrial and commercial uses, as well as live/work and residential uses. The Hybrid Industrial Subarea does not include limits on residential floor area.

#### **Industrial Subarea K (“Compatible Industrial”)**

The Compatible Industrial Subarea is applied to industrial land uses located adjacent to residential neighborhoods, which therefore require greater sensitivity through development standards and limitations on allowed uses. This Subarea allows light industrial and commercial uses, while restricting noxious and other incompatible uses.

#### **Industrial Subarea L (“Industrial Innovation”)**

The Industrial Innovation Subarea protects viable industrial areas. This Subarea allows a broad range of industrial uses that support the City’s employment base, and limits non-industrial uses. This Subarea is important to provide land for

existing businesses and industry, as well as emerging businesses in clean and green technology, research and development, and food production, among others. Use restrictions limit non-industrial uses from encroaching into the stable industrial districts to ensure the economic sustainability of the community and the City.

### **Residential Subareas M, N and O**

Residential Subareas M, N and O focus on encouraging well-designed projects that are compatible with the surrounding neighborhood scale and that enhance neighborhood character.

The three Residential Subareas are shown on Figures V-1 and V-2 and are summarized as follows:

#### **Residential Subarea M (“Legacy Single-Family”)**

The Legacy Single-Family Subarea preserves the single-family character of certain lower density neighborhoods. Development standards ensure that building mass and setbacks keep new development projects in balance with the existing environment.

#### **Residential Subarea N (“Multi-Family”)**

The Multi-Family Subarea establishes development standards for higher density neighborhoods in order to ensure that new development projects are well-designed and represent a step forward for their respective neighborhoods.

#### **Residential Subarea O (“Character Residential”)**

The Character Residential Subarea includes neighborhoods that have an abundance of historically and architecturally significant buildings. Development standards within this Subarea guide the ongoing maintenance of these structures, and regulations ensure that new development projects complement the surrounding context, including protecting patterns of historic parcelization. Eligible historic resources are subject to an additional level of review.

*(As of the date of adoption of this Ordinance, no properties are designated Subarea O in the Southeast Los Angeles Community Plan Area.)*

## Section I-4. DEFINITIONS

Whenever the following terms are used in this ordinance, they shall be construed as defined in this Section I-4. Words and phrases not defined in this section shall be construed as defined in Chapter 1 of the LAMC, including, but not limited to, Sections 12.03 and 14.4.2. The definitions set forth in this ordinance that reference, or incorporate by reference, other statutes or ordinances are deemed to be amended when those statutes or ordinances are amended from time to time.

### A. General Definitions

**Active Floor Area** – Ground Floor area that is directly accessible from a building’s Primary Frontage, and that is dedicated to any of the following: Commercial Uses, residential lobbies, Community Facilities, or Pedestrian Amenities.

**Administrative Clearance** – A ministerial approval for a Project in a Southeast Los Angeles CPIO District Subarea that is obtained pursuant to Section I-6.C.2 of this ordinance.

**Alcohol Sales, Off-Site** – Any establishment licensed by the Department of Alcoholic Beverage Control to sell or otherwise dispense alcoholic beverages for consumption off-site of the premises.

**Architectural Feature** – An aesthetic element of a building’s design that is integral to the overall style of architecture, but is not considered habitable or is otherwise counted as part of a building’s floor area.

**Auto-Related Use** – A Car Wash, or any of the following uses, as defined in LAMC Section 12.03: automotive use, automobile dismantling yard, automobile and trailer sales area, automotive repair, and automotive fueling and service station. This term does not include New Franchise Automobile Sales, the retail sales of new automobile parts, or electric vehicle charging stations as defined in Government Code Section 65850.7.

**Bank** – A financial institution that is regulated by the Office of the Controller of the Currency, the Federal Reserve, or the Federal Deposit Insurance Corporation (FDIC) or chartered by the California Department of Business Oversight, and whose deposits are insured by the FDIC, and licensed to conduct business in the state of California. This term does not include short-term loan facilities and establishments that provide only ATM access or check cashing.

**Base** – The maximum density, height or floor area ratio (FAR) permitted on a Project site by this CPIO District, excluding any available CPIO Bonus.

**Building Footprint** – The area under the horizontal projection of the roof that is surrounded by the exterior walls or columns of a building, exclusive of courtyards.

**Canister/Can/Cabinet Sign** – An opaque or clear sign with illuminated or non-illuminated text, logos, or symbols placed on, behind, or extruded through the plastic face of an enclosed cabinet attached to the face of building.

**Car Wash** – An establishment that provides services related to the on-site cleaning of motor vehicles. This business may include self-service cleaning equipment, or fully automated equipment (such as an automotive laundry or wash rack that is power driven or involves steam cleaning machinery).

**CEQA** – The California Environmental Quality Act, Public Resources Code Sections 21000, *et seq.*, and the guidelines adopted in California Code of Regulations, Title 14, Chapter 3, Sections 15000 – 15387 (CEQA Guidelines).

**Check Cashing Facility and/or Payday Lender** – Lending facilities offering small, unsecured, short-term loans, or a use that primarily consists of check cashing services for a fee.

**Commercial Uses** – Those uses first permitted in the CR, C1, C1.5, C2, C4, or C5 Zones, including Community Facilities and hotels. This term does not include residential uses, with the exception of hotels.

**Community Facilities** – Any use whose primary purpose is to provide government, non-profit, or not-for-profit assistance to the general public. Examples include government offices and services or privately funded services or charities that are provided to the public at a free or subsidized rate, child care centers, job assistance centers, business assistance centers, libraries, schools, adult day cares, Health Centers, museums, cultural centers, gyms or recreation centers, restrooms open to the general public and rooms available to the general public for community meetings. Public parking structures are Community Facilities when they include another Community Facility use, such as child care centers or community meeting rooms. Community Facilities include any related administrative offices.

**Community Plan** – The Southeast Los Angeles Community Plan.

**CPIO Approval** – An approval issued under Section I-6.C of this ordinance that is an Administrative Clearance, a CPIO Adjustment, or a CPIO Exception.

**CPIO Affordable Housing Project** – A Project of five residential units or more, which may also include Commercial Uses, that qualifies as either a CPIO 100 Percent Affordable Housing Project or a CPIO Mixed-Income Housing Project.

**CPIO Bonus** – Any available increase over the Base permitted to be built on a Project site by this CPIO District.

**CPIO 100 Percent Affordable Housing Project** – A project in which 100 percent of the residential dwelling units, excluding any manager unit(s), are Restricted Affordable Units.

**CPIO Mixed-Income Housing Project** – A project comprised of a mix of market-rate and Restricted Affordable Units at the following percentages:

1. For TOD Subarea E (“TOD Low”), a minimum of 21 percent of the total units in the Project, excluding any manager unit(s), are designated for Lower Income households, or 12 percent for Very Low Income households, or 9 percent for Extremely Low Income Households
2. For TOD Subareas F (“TOD Medium”), G (“TOD High), and H (“TOD Regional”) a minimum of 25 percent of the total units in the Project, excluding any manager unit(s), are designated for Lower Income Households, or 15 percent for Very Low Income households; or 11 percent for Extremely Low Income Households.

**Creative Office Use** – A business establishment that is primarily involved in the generation or utilization of knowledge and information or the development of creative property, including advertising, architectural services, computer software design, engineering, graphic design, interior design, and landscape design uses.

**Credit Union** – A “Federal credit union” or “State credit union” as defined by 12 United States Code Section 1752.

**Density Bonus Project** – A Project that meets the eligibility requirements of and elects to use the density increases, waivers and incentives set forth in LAMC Section 12.22 A.25.

**Designated Historic Resource** – A building, structure, landscaping element, or natural feature listed or designated as a historical resource, either individually, or as a contributor to a district, through a local, state or federal designation program.

**Drive-Through Establishment** – Any business used for the execution of a sale, or business transaction, to an individual in a motor vehicle at the time of the sale or transaction.

**Eligible Historic Resource** – A building, structure, object, site, landscape, natural feature, or historic district identified as eligible for listing either individually, or as a contributor to an eligible historic district under a local, state or federal designation program, through SurveyLA (*The Los Angeles Historic Resources Survey*), or another historical resource survey completed by a person meeting the Secretary of the Interior’s Professional Qualification Standards for Historic Preservation and accepted as complete by the Director, in consultation with the Office of Historic Resources (OHR). This term does not include a non-contributor to an eligible historic district.

**Extremely Low Income Households** – As defined in Health and Safety Code Section 50106.

**Feather Sign** – A freestanding or mounted sign that is supported by a flexible or semi-flexible full or partial frame within which is a material constructed of vinyl, paper, or other wind-resistant and moveable materials.

**Freestanding Restaurant with Drive-Through** – A restaurant use or uses by a single tenant, or multiple tenants that share the same kitchen, located on its own lot or within a shopping center complex, that includes a drive-through.

**Full-Service Drug Store** – A retail establishment, of 10,000 square feet or more of floor area, where medical prescriptions, drugs, medical supplies, and other merchandise is sold.

**Full-Service Fitness Center** – A facility, of 10,000 square feet or more of floor area, that provides the general public services, gym-related equipment, and instructional training related to personal physical fitness. This term does not include massage parlors and spas.

**Full-Service Grocery Store** – A retail establishment, of 10,000 square feet or more of floor area, that dedicates at least 25 percent of its floor area to perishable food items, and also offers for sale a selection of packaged food, fresh food, and household items. Items for sale may include fresh and packaged meats, dairy products, produce, dry goods, frozen goods, sundries, paper goods, and other similar products.

**Ground Floor** – The floor level which is within three feet above or below curb level, accessible to the street, has frontage on a Primary Lot Line, and is at least 25 feet in depth or is the total depth of the building, whichever is less.

**Gun Shop** – A business establishment lawfully authorized to engage in the retail sale, leasing, purchasing, lending, or the commercial storage of guns, firearms, or ammunition.

**Health Center** – A facility that provides health care and is certified by the United States Department of Health and Human Services, Health Resources and Services Administration (HRSA) as a Federally Qualified Health Center (FQHC), or FQHC Look-Alike as defined by HRSA.

**LAMC** – Los Angeles Municipal Code.

**LADOT** – Los Angeles Department of Transportation

**Light Manufacturing and Assembly** – A business establishment where any on-site processing, fabricating, assembly or disassembly of items takes place within an enclosed building so that all noise, dust, odors and other potential nuisances from operations are contained entirely on-site. Typical items for processing, fabricating, assembly or disassembly under this use include, but are not limited to, apparel, apparel accessories, computers, decorations, electronic devices, food, instruments, jewelry and textiles. This term does not include Noxious Uses.

**Lower Income Households** – As defined in Health and Safety Code Section 50079.5(a).

**Major Retailers** – A business establishment that provides 50,000 square feet or more of a retail use as first allowed in the C1.5 zone.

**Media Production** – A business establishment that is engaged in the creation or production of film, television, video, audio, animation, or the editing of any related media content. This term includes any accessory private screening rooms. This term does not include movie theaters open to the general public.

**Mixed-Use Project** – A Project which combines multiple Residential Uses with one or more Commercial Uses, such as, retail, office, and Community Facilities in a single building or in a Unified Development.

**Motel** – An establishment primarily designed for the accommodation of motorists and which provides lodging with limited amenities and features on-site parking that is directly accessible and often visible from each unit. This term includes a motor court or motor lodge. This term does not include hotels as defined in LAMC Section 12.03.

**Multi-Purpose Cultural Facilities** – A facility designed to host a social gathering and consisting of multipurpose meeting and/or recreational facilities, typically consisting of one or more meeting or multipurpose rooms and a kitchen and/or outdoor barbecue facilities, that are available for use by various public or private groups for activities, such as meetings, parties, weddings, receptions, exhibits and entertainment.

**New Franchise Automobile Sales** – A business establishment that generates a majority of its revenue from the authorized retail sale of vehicles obtained directly from the vehicle manufacturer. This term may include related ancillary uses such as used automobile sales, auto mechanic/repair, and Car Wash.

**Noxious Use** – An establishment which requires a permit from South Coast Air Quality Management District related to the following activities: petroleum refining, chemical manufacturing, plastics and resin manufacturing, pharmaceutical manufacturing, paint and coatings, iron and steelmaking, secondary smelting and refining, metal manufacturing, electroplating, metal processing, chrome plating, circuit board manufacturing, oil and gas production wells and automobile manufacturing.

**Pawnshop** – An establishment engaged in the “pawnbroker” business as defined by Financial Code Section 21000.

**Pedestrian Amenities** – Any public or private improvement that facilitates direct, safe, attractive, accessible, and recreational walking. This term includes outdoor sidewalk cafes, Public Plazas, retail courtyards, water features, kiosks, paseos, arcades, patios, covered walkways, or spaces of outdoor dining or seating that are located on the Ground Floor, and that are accessible to and available for use by pedestrians.

**Primary Frontage** – The exterior building walls facing the Primary Lot Line. For the purposes of this definition, all exterior walls that intersect a plane parallel to the Primary Lot Line at 45 degrees or less shall be considered the Primary Frontage. When the Primary Lot Line is not straight, a line connecting the points where the secondary or side lot lines and the Primary Lot Line intersect shall be used.

**Primary Lot Line** – The property line of a lot that is contiguous with a public street. On lots fronting more than one public street, the Director of Planning shall determine the Primary Lot Line based upon neighborhood characteristics, including the designation of the abutting streets and the dimensions of the subject lot.

**Professional Office Uses** – An establishment that provides general office space for business services that require specialized training or professional certification including but not limited to accountant, appraiser, attorney, architect, landscape architect, engineer, surveyor, stockbroker, counselor, and psychologist. This term does not include massage parlors and spas. This term shall not include medical or dental office uses or the sale or exchange of goods and merchandise.

**Project** – Any activity that requires the issuance of a building, grading, demolition or change of use permit, unless the activity consists solely of interior rehabilitation/repair work.

**Public Plaza** – A common open area for public use typically amenable to larger public gatherings and adjacent to active building uses that is located on the ground level with direct pedestrian access to the adjacent street; is at least 50 percent open to the sky; is unenclosed by any wall, fence, gate, or other obstruction across the subject property, includes at least one gathering space with a focal element such as a fountain or work of art and signs at each pedestrian access point that contain language substantially consistent with the following: “This Plaza is open to the public as required by the Southeast Los Angeles CPIO District.”

**Publicly Accessible Open Space** – Public Plazas, pocket parks, and passive and active recreation areas that are accessible for use by the general public at least during the hours of, 10:00 a.m. and 5:00 p.m. daily and signs at each pedestrian access point that contain language substantially consistent with the following: “This area is open to the public as required by the Southeast Los Angeles CPIO District.”

**Public Self Storage** – A “self-service storage facility” as defined by Business and Professions Code Section 21701(a).

**Recycling Collection** – A “recycling center” as defined by Public Resources Code Section 14520, or a “recycler” as defined by Public Resources Code Section 14519.5.

**Rehabilitation** – The act or process of returning a property to a state of utility, through repair or alteration, which makes possible an efficient contemporary use while preserving those portions or features of the property which are significant to its historical, architectural, and cultural values.

**Research and Development** – Any establishment engaged in scientific and technical research leading to the development of new products and processes, including development/testing activities and prototype fabrication.

**Restricted Affordable Unit** – A residential unit for which the amount of rent is restricted by a covenant so as to be affordable to and occupied by Extremely Low, Very Low, or Lower Income Households, as determined by the Los Angeles Housing and Community Investment Department (“HCIDLA”).

**Residential Uses** – Those uses first permitted in any R zone, including dwelling units, guest rooms, and live-work units.

**Restoration** – The act or process of accurately recovering the form, features, and details of a property as it appeared at a particular period of time by means of the removal of later work or by the replacement of missing earlier work.

**Retail Sales** – Any establishment that sells either new or used goods to the final consumer of such new or used goods for household, institutional, or industrial uses as permitted by the underlying zone.

**Sensitive Land Uses** – Residences, schools and schoolyards, parks and playgrounds, athletic facilities, day or child care centers, nursing homes, hospitals, long-term health care facilities, rehabilitation centers, convalescent centers, retirement homes, and residential communities.

**Sit-Down Restaurant** – An establishment that sells food for consumption on the premises, or through incidental take-out service, and which has the following characteristics: a varied menu; table service with orders taken either at the table or the counter; and food served to tables using dishes and glasses.

**Smoke/Vapor Shops** – An establishment that primarily sells devices intended for smoking and/or tobacco products, including establishments that sell e-cigarettes or other devices used for the vaporization of oils, waxes, liquid nicotine, dry herbs or other e-liquids. This term does not include medical or recreational marijuana dispensaries.

**Street-Oriented Entrance** – A building entrance (or in the case of multi-tenant structures, multiple entrances) that is visible and directly accessible from the Primary Lot Line and that is enhanced with Architectural Features to denote the entrance from the rest of the façade.

**Swap Meet** – As defined by Business and Professions Code Section 21661. This term does not include farmer’s markets or garage or yard sales.

**Targeted Commercial Uses** – Banks, Credit Unions, child care facilities, Full-Service Drug Stores, Health Centers, Full-Service Fitness Centers, Full-Service Grocery Stores, and Sit-Down Restaurants as those terms are defined by this ordinance or the LAMC.

**Transit-Oriented Communities Project (TOC Project)** – A Project that meets the requirements of and elects to use the density increases, waivers and incentives set forth in LAMC Section 12.22 A.31 and its implementing guidelines.

**Unified Development** – A development of two or more buildings which have functional linkages such as pedestrian or vehicular connections, with common architectural and landscape features which constitute distinctive design elements of the development, and that appears to be a consolidated whole when viewed from adjoining streets. Unified Developments may include two or more contiguous parcels or lots of record separated only by a street or alley.

**Unified Lots** – Two or more legal lots owned by one or more owners, which through legal instrument are controlled or developed as one lot, such as lots subject to a covenant, known as a, “covenant to hold property as one parcel.”

**Very Low Income Households** – As defined in Health and Safety Code Section 50105.

**Vocational School** – An establishment that provides job training and educational facilities for a variety of technical skills.

**Warehouse/Storage Building** – As defined by Commercial Code Section 7102. This term includes a cold storage facility.

## **Section I-5. RELATIONSHIP TO OTHER ZONING REGULATIONS**

- A.** In addition to the provisions in LAMC Section 13.14.B, the following exceptions apply unless expressly stated to the contrary in the CPIO Subarea regulations:
1. The Greater Downtown Housing Incentive Area Ordinance set forth in LAMC Section 12.22.A.29 does not apply to Subareas E, F and G.
  2. The Mini-Shopping Center Commercial Corner Development Standards and Conditions of Operation set forth in LAMC Section 12.22.A.23 do not apply in any Subareas.
  3. Except where expressly stated otherwise in the Southeast Los Angeles CPIO District, small lot subdivision projects involving single-family dwellings shall be regulated pursuant to LAMC Section 12.22.C.27.
- B.** The maximum FAR available to Affordable Housing Incentive Projects located in Height District 1 shall also apply when located in Height District 2D.

- C. Nothing in the Southeast Los Angeles CPIO District is intended to override or conflict with any regulations in the LAMC or other ordinance establishing a park or Quimby fee or park or open space dedication requirement, including any provisions related to credits or fee and dedication calculations.
- D. Nothing in this Southeast Los Angeles CPIO District is intended to override or conflict with any regulations in the LAMC that would otherwise require a conditional use permit.
- E. Nothing in this Southeast Los Angeles CPIO District is intended to override or conflict with any bicycle parking regulations.
- F. Nothing in this Southeast Los Angeles CPIO District is intended to override or conflict with the regulations set forth in LAMC 12.22.A.25 and 12.22.A.31 that provide bonuses, waivers and incentives for certain affordable housing projects.
- G. If there are any conflicts between the provisions of the Southeast Los Angeles CPIO regulating building height or transitional building height and any other zoning regulations, including the regulations set forth in LAMC 12.21.1 through 12.21.6, the provisions of the Southeast Los Angeles CPIO shall govern.

#### **Section I-6. REVIEW PROCEDURES**

- A. **Prohibition of Issuance of DBS Permits Prior to CPIO Approval.** The Department of Building and Safety (DBS) shall not issue a permit for any Project within a Southeast Los Angeles CPIO District Subarea (in whole or in part), unless the Project has been reviewed and approved in accordance with this Section I-6.
- B. **Filing Requirements for Multiple Approvals.** When an applicant applies for any discretionary approval under LAMC Chapter 1 for a property located (in whole or in part) in a CPIO District Subarea, the applicant shall also apply for a CPIO Approval pursuant to Subsection C, below. A CPIO Adjustment or a CPIO Exception shall be a quasi-judicial approval for purposes of LAMC Section 12.36.A, and shall be processed pursuant to the procedures in LAMC Section 12.36, if applicable.
- C. **CPIO Approval.** All Projects within a Southeast Los Angeles CPIO District Subarea (in whole or in part) shall obtain an Administrative Clearance, unless a CPIO Adjustment or CPIO Exception is otherwise required, to demonstrate compliance with the Southeast Los Angeles CPIO District, including the Environmental Standards set forth in Section I-8 and Appendix A. For any requirement for which the Project cannot demonstrate compliance, the Project shall obtain a CPIO Adjustment or CPIO Exception, if permitted by the Southeast Los Angeles CPIO District. An application for a CPIO Approval shall be reviewed and approved pursuant to LAMC Section 13.14.G, including as its requirements are modified and supplemented below:
  - 1. **Content of Application for a CPIO Approval.** In addition to any other information or documents required under LAMC Section 13.14.G.1, an applicant shall provide, at a minimum, two sets of detailed permit drawings and any other exhibits deemed necessary to demonstrate compliance with all applicable provisions of the CPIO District. Each application submitted for a CPIO Adjustment, or a CPIO Exception shall clearly identify and list all of the adjustments and exceptions requested.

2. **Administrative Clearance.** In addition to the requirements in Section 13.14.G.2, the following shall apply:
  - (a) **Director Approval.** The Director shall grant an Administrative Clearance after reviewing the Project and finding that it is in compliance with all applicable provisions of the Southeast Los Angeles CPIO District as indicated by a plan stamped by the Department of City Planning.
  - (b) **Non-Appealable Ministerial Approval.** The approval of an Administrative Clearance is not subject to appeal and is not discretionary for purposes of CEQA Guidelines Sections 15060(c)(1) and 15268.
  - (c) **Scope of Review and Non-Conforming Uses.**
    - (i) In reviewing a Project for an Administrative Clearance, the Director shall review the Project for compliance with those regulations that are applicable to the proposed scope of construction or use. For example, a Project that involves only façade improvements shall comply with applicable façade standards, but need not comply with parking lot standards.
    - (ii) Non-conforming uses shall comply with LAMC Section 12.23, except as noted in Section IV.B.1 of this ordinance.
3. **CPIO Adjustments.** In addition to the requirements in LAMC Section 13.14.G.3, the following shall apply:
  - (a) **Findings.** In addition to the required findings in LAMC Section 13.14.G.3(b), the Director, or the Area Planning Commission on appeal, shall find that the Project substantially complies with the Design Guidelines in Appendix B of the Southeast Los Angeles Community Plan or any applicable citywide design guidelines.
  - (b) **Eligible Regulations.** Unless expressly stated otherwise in this Southeast Los Angeles CPIO District, all development regulations are eligible for a CPIO Adjustment pursuant to this Section I-6.C.3. Projects seeking relief from a Subarea regulation that is not eligible (or further eligible) for a CPIO Adjustment may seek relief with a CPIO Exception.
  - (c) **CEQA.** Approval of a CPIO Adjustment is a discretionary approval for purposes of CEQA Guidelines Section 15060(c)(1).
4. **CPIO Exceptions.** In addition to the requirements in LAMC Section 13.14.G.4, the following shall apply:
  - (a) **Findings.** In addition to the required findings in LAMC Section 13.14.G.4(b), the Area Planning Commission, or the City Council on appeal, shall find that the Project substantially complies with the Design

Guidelines attached as Appendix B to the Southeast Los Angeles Community Plan or any applicable citywide design guidelines.

- (b) **CEQA.** Approval of a CPIO Exception is a discretionary approval for purposes of CEQA Guidelines Section 15060(c)(1).
- (c) **Supplemental Development Regulations.** All Projects shall comply with all applicable supplemental development regulations in the applicable CPIO Subarea, unless a CPIO Adjustment or CPIO Exception is permitted and obtained or the Project falls within the category of Projects described in Section I-5.F of this CPIO District. Images and figures provided in the CPIO District are illustrative only and are not intended to establish supplemental development regulations.

5. **Eligible Historic Resource Evaluation.** Prior to any other CPIO Approval being issued, a Project that involves an Eligible Historic Resource shall comply with the following review procedures:

- (a) **Non-Demolitions.** For any Project that does not involve the demolition of an Eligible Historic Resource, no CPIO Approval shall be issued until one of the following occurs:
  - (i) The Director, in consultation with the Office of Historic Resources, determines, based upon substantial evidence, that the Eligible Historic Resource is not an historical resource, as defined by Public Resources Code Section 21084.1;
  - (ii) The Director, in consultation with the Office of Historic Resources, determines, based upon substantial evidence, that the Project is consistent with the Secretary of Interior's Standards for the Treatment of Historic Properties with Guidelines for Preserving, Rehabilitating, Restoring, and Reconstructing Historic Buildings; or,
  - (iii) Environmental review in compliance with CEQA was completed for the Project, including if necessary, the adoption of a statement of overriding considerations.
- (b) **Demolitions.** For any Project that involves the demolition of an Eligible Historic Resource, no CPIO Approval shall be issued until one of the following occurs:
  - (i) The Director, in consultation with the Office of Historic Resources, determines, based upon substantial evidence, that the Eligible Historic Resource is not an historical resource, as defined by Public Resources Code Section 21084.1; or
  - (ii) Environmental review in compliance with CEQA was completed on the Project, including if necessary, the adoption of a statement of overriding considerations.

- (c) **CEQA Review for Eligible Historic Resources.** In complying with this Section I-6.C.5, if at any time the Director, in consultation with the Office of Historic Resources, determines the Eligible Historic Resource is not a historical resource as defined by Public Resources Code Section 21084.1, approval of the Project through an Administrative Clearance (involving no other discretionary approvals) shall be a ministerial approval for purposes of CEQA, including CEQA Guidelines, Section 15268. If the Director, in consultation with the Office of Historical Resources, determines the Eligible Historic Resource is a historical resource as defined by Public Resource Code Section 21084.1, approval of the Project through an Administrative Clearance shall be a discretionary approval for purposes of CEQA Guidelines, Section 15060(c)(1). In reviewing and approving a Project with a historical resource, the Director and Office of Historic Resources shall take such steps within the scope of their powers and duties as they determine are necessary for the preservation of the historical resource, including but not limited to, consulting with the applicant to provide voluntary options for preservation or initiating a formal designation process.
- (d) **Appeals.** No determination of the Director in this Section I-6.C.5 is independently appealable unless an appeal of an entitlement or CEQA action is otherwise available through this CPIO District, the LAMC, or CEQA.

#### **Section I-7. RIGHT-OF-WAY IMPROVEMENTS AND STREETScape PLANS**

- A. Streetscape Requirements.** When right-of-way improvements are required of any Project, pursuant to LAMC Section 12.37, Articles 2 or 7 of LAMC Chapter 1, or other City ordinance, and the right-of-way is subject to a streetscape plan, the improvements shall be consistent with the streetscape plan unless the LADOT General Manager or the City Engineer finds either of the following:
1. Consistency with the streetscape plan is not feasible or practical;
  2. The cost of making the improvement consistent with the streetscape plan disproportionately exceeds the cost to other property owners who are required to make improvements consistent with the streetscape plan.
- B. Non-Conforming Improvements.** Notwithstanding anything to the contrary in LAMC Section 12.37.A.3 or another adopted City ordinance, improvement requirements shall not be waived or excused for a Project on the basis that the existing improvements currently meet existing City standards and requirements, unless the improvement also conforms to any streetscape plan for the right-of-way. If existing improvements do not conform to the streetscape plan, they will need to be improved to meet the streetscape plan standards unless the City Engineer or LADOT General Manager make the findings in Subsection A, above, or the improvement requirement is otherwise successfully appealed under Subsection E, below.
- C. Streetscape Plan.** For purposes of this Section, “streetscape plan” shall refer to a plan that was approved by the Board of Public Works or the City Planning Commission, or both, or the City Council, and the plan is consistent with the Community Plan, the

Circulation Element of the General Plan, and the Transportation Demand Management and Trip Reduction Measures of LAMC Section 12.26.J (as determined by LADOT), and is necessary or desirable to improve the aesthetic character of the street and encourage the use of transit and active transportation.

- D. **Consistency Determination.** Consistency with the streetscape plan shall be determined by the LADOT General Manager, after consultation with the Director and the City Engineer.
- E. **Appeal.** An applicant may appeal any streetscape improvement requirement in Subsection A and B, including the findings under Subsections A.1 or A.2., through any appeal process that is available for the imposition of the underlying right-of-way improvement requirement. For example, if the underlying improvement is being imposed under LAMC Section 12.37, the requirement to improve the right-of-way consistent with the streetscape plan may be appealed under LAMC Section 12.37.I. If the underlying improvement is being imposed under LAMC Section 17.08 on a parcel map, the requirement to improve the right-of-way consistent with the streetscape plan may be appealed under LAMC Section 17.54.
- F. **Subsequent Ordinance.** If the City Council later adopts an ordinance to regulate streetscape plan improvements and the ordinance is applicable to the CPIO District, this Section I-7 shall be of no further force and effect.

#### **Section I-8. ENVIRONMENTAL STANDARDS PROCEDURES**

The Environmental Standards in Appendix A are included in the Southeast Los Angeles CPIO District to implement the Mitigation & Monitoring Program included as part of the South Los Angeles and Southeast Los Angeles Community Plans update and reviewed in the City of Los Angeles South Los Angeles and Southeast Los Angeles Community Plans Environmental Impact Report (Case No. ENV-2008-1780-EIR), certified on November 22, 2017.

An applicant seeking a CPIO Approval shall comply with all applicable Environmental Standards as set forth in Appendix A, subject to the following rules.

- A. **Applicability of Environmental Standards.** A Project does not need to comply with any Environmental Standard that is not relevant to the scope of activities involved with the Project. For example, a Project that proposes only minor façade alterations and no grading, shall not be subject to Environmental Standards that apply to grading activities (such as noise and vibration standards). The Director, in his or her reasonable discretion, shall determine those Environmental Standards that apply to a particular Project.
- B. **Plans.** Compliance with all applicable Environmental Standards listed in Appendix A shall be demonstrated on the plans as project features (that is, features that are physically built into the Project such as an air filtration system) or as operational features listed on a sheet within the plans (that is, features that are carried out either during the construction of the Project, or over the life of the project, such as the use of paints, sealants, and other building materials that yield low air pollutants).
- C. **CPIO Approvals.** No CPIO Approval shall be issued until an applicant has demonstrated substantial compliance with all applicable Environmental Standards or

modified Environmental Standards approved pursuant to Subsection D, below.  
Determination of substantial compliance shall be at the discretion of the Director.

- D. Modification of Environmental Standards.** Modifications of Environmental Standards do not require the processing of a CPIO Adjustment or CPIO Exception. The Director (or appeal body on appeal) may modify or dispense with an Environmental Standard listed in Appendix A for any Project when: (1) the Director finds in writing, based upon substantial evidence, the Environmental Standard is not necessary to mitigate an impact, including because of the existence of a similar or more effective regulation that applies to the Project; (2) the City complies with CEQA Guidelines, Section 15162, including by preparing an addendum or subsequent environmental clearance to the South Los Angeles and Southeast Los Angeles Community Plans EIR to analyze the impacts from the modifications to the Environmental Standards; or (3) the City prepares a new CEQA clearance for the Project. No CPIO Approval shall be issued for a Project with a modified Environmental Standard until this subsection has been complied with. The modification of an Environmental Standard is not independently appealable unless an appeal of an entitlement or CEQA determination is otherwise available through this CPIO District, the LAMC, or CEQA.

#### **Section I-9. USE OF DESIGN GUIDELINES**

The Design Guidelines in Appendix B of the Southeast Los Angeles Community Plan and any other applicable citywide design guidelines are not mandatory or required for an Administrative Clearance. The guidelines should be used by decision makers in the review and approval of discretionary zoning approvals within the CPIO District boundaries that require findings related to neighborhood compatibility, the degradation or benefit of the Project to surrounding properties and the community, and conformity with the intent and purpose of the Community Plan. Such zoning approvals include, but are not limited to, CPIO Adjustments, CPIO Exceptions, and conditional use permits under LAMC Section 12.24.

Nothing in this section, the Southeast Los Angeles CPIO District, or any other applicable citywide design guidelines, shall allow decision makers to approve, deny, or condition a discretionary approval based on guidelines related to signs. Any design guidelines related to signs in Appendix B of the Southeast Los Angeles Community Plan or any other citywide design guidelines are for guidance only.

#### **Section I-10. CEQA CLEARANCE**

For purposes of CEQA compliance for subsequent projects approved with a CPIO Approval, including, but not limited to, consideration of a CEQA clearance pursuant to Government Code Section 65457, Public Resources Code Section 21155.4; or CEQA Guidelines, Sections 15183 or 15183.3, the Southeast Los Angeles CPIO District shall operate and be treated as a specific plan, zoning ordinance, and a prior plan level decision for which an EIR was certified.

#### **Section I-11. SEVERABILITY**

If any portion, subsection, sentence, clause or phrase of this ordinance is for any reason held by a court of competent jurisdiction to be invalid, such a decision shall not affect the validity of the remaining portions of this ordinance. The City Council hereby declares that it would have passed this ordinance and each portion or subsection, sentence, clause and phrase herein, irrespective

of the fact that any one or more portions, subsections, sentences, clauses or phrases be declared invalid.

# CHAPTER II – CORRIDORS SUBAREAS

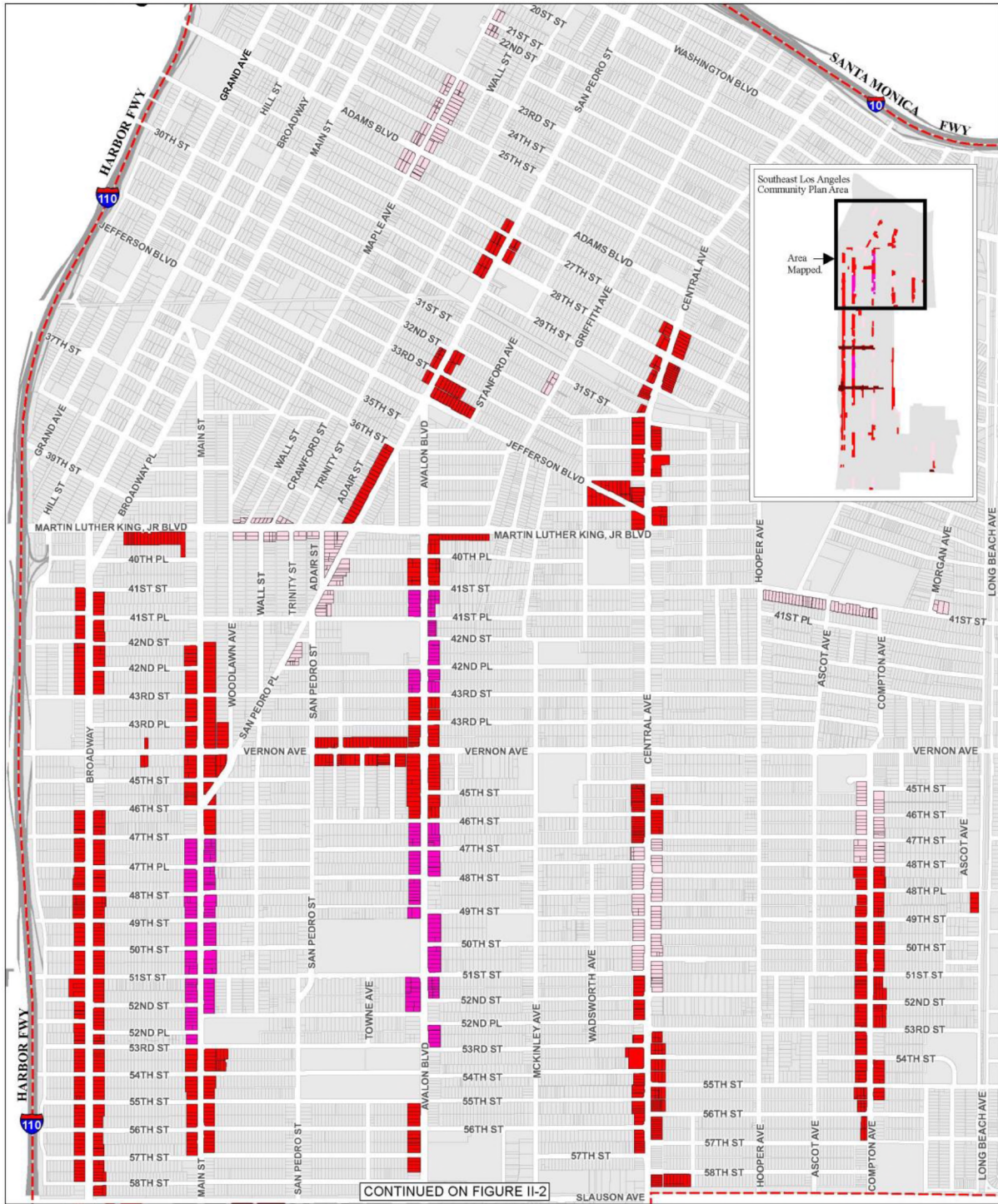
## **CORRIDORS SUBAREAS**

- A – Neighborhood-Serving Corridor
- B – Parkway Corridor
- C – General Corridor
- D – Commercial Corridor

## **OVERVIEW**

Corridors Subareas A, B, C, and D seek to foster continued investment in the various commercial corridors throughout Southeast Los Angeles as described in Section I-3 consistent with the purposes set forth in Section I-2.

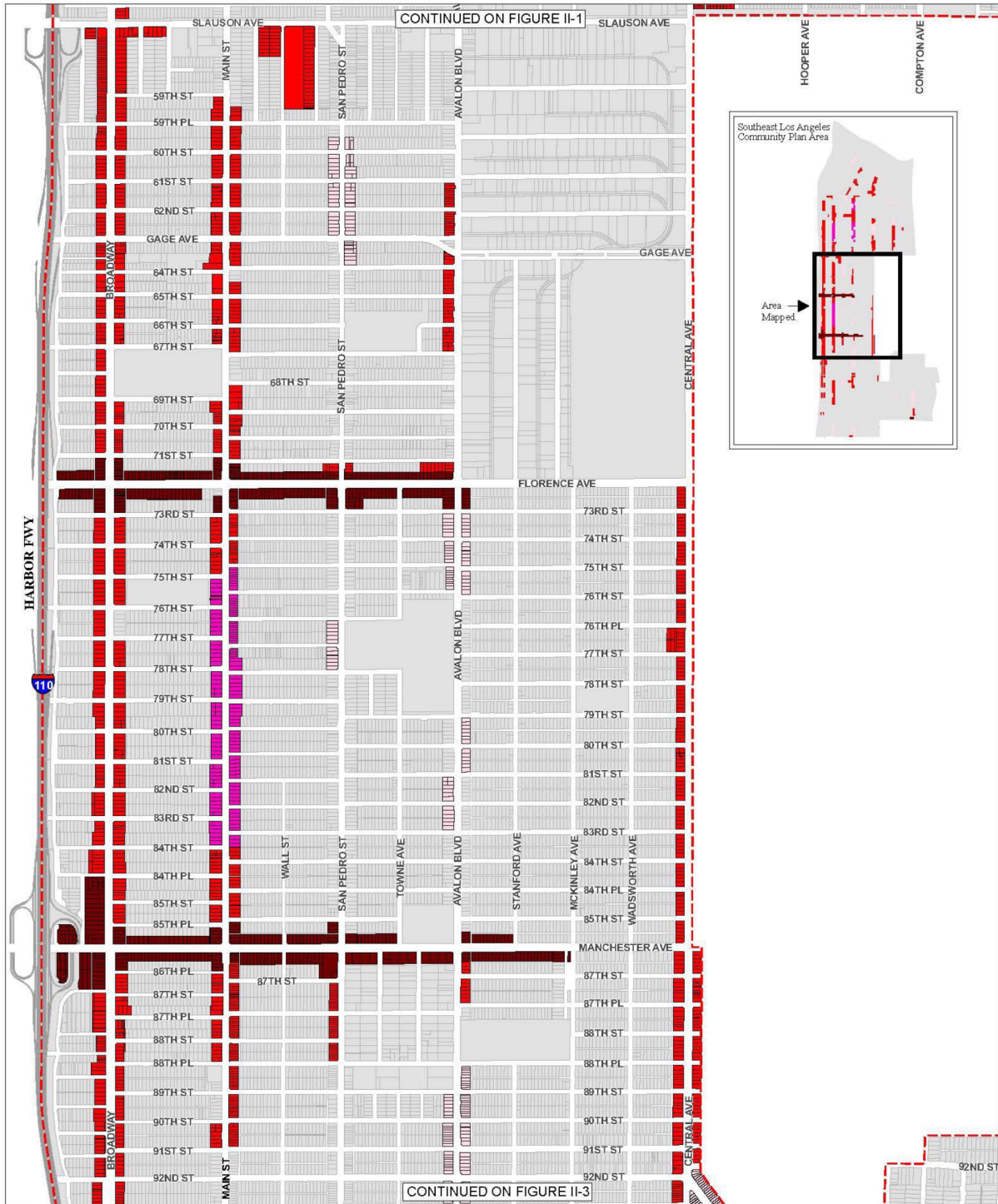
The intent of the supplemental development regulations in this Chapter is to revitalize neighborhood commercial areas to better serve nearby residential neighborhoods. Basic development standards promote the aesthetic upgrading of the subarea, and regulations seek to encourage a diverse range of services and retail uses. Projects within a Corridors Subarea (See Figures II-1, II-2, II-3 ,and II-4) shall comply with the applicable supplemental development regulations in this Chapter.



**FIGURE II-1. CORRIDORS SUBAREAS**

- Subarea A - Neighborhood - Serving Corridor
- Subarea B - Parkway Corridor
- Subarea C - General Corridor
- Southeast Los Angeles CPA

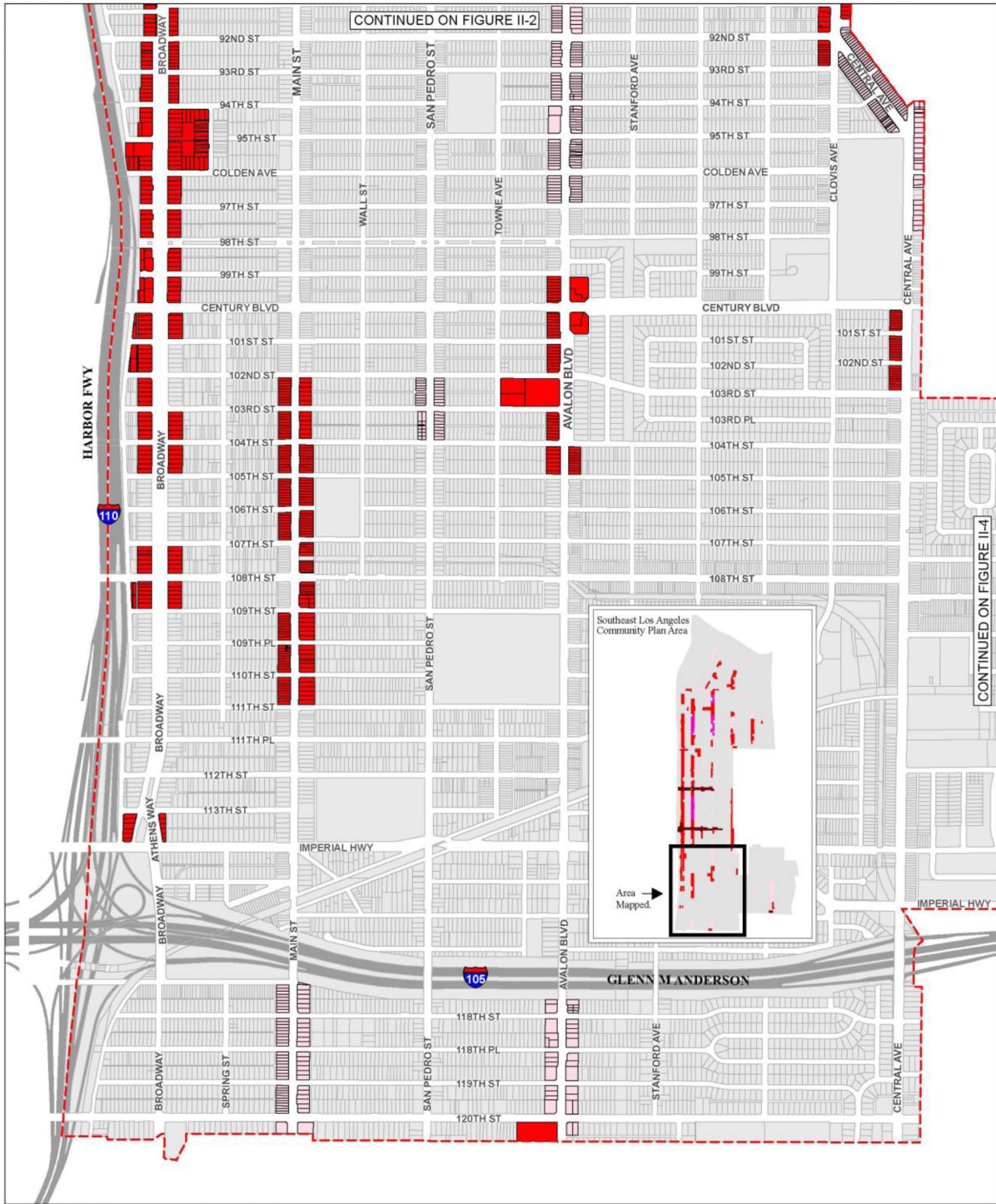




**FIGURE II-2. CORRIDORS SUBAREAS**

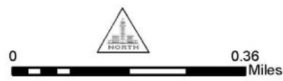
- Subarea A - Neighborhood - Serving Corridor
- Subarea B - Parkway Corridor
- Subarea C - General Corridor
- Subarea D - Commercial Corridor
- Southeast Los Angeles CPA

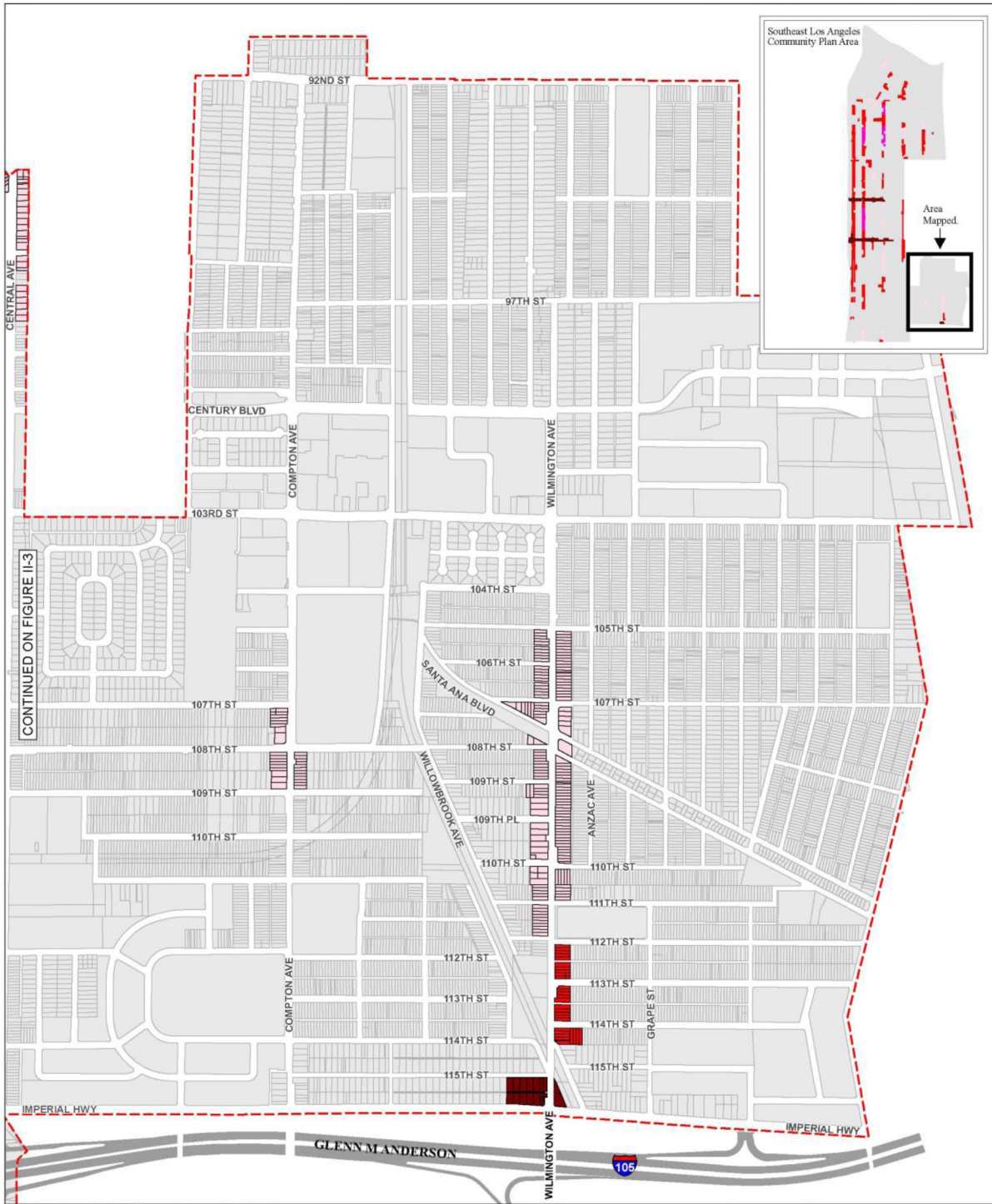




**FIGURE II-3. CORRIDORS SUBAREAS**

- Subarea A - Neighborhood - Serving Corridor
- Subarea C - General Corridor
- Southeast Los Angeles CPA





**FIGURE II-4. CORRIDORS SUBAREAS**

- Subarea A - Neighborhood - Serving Corridor
- Subarea C - General Corridor
- Subarea D - Commercial Corridor
- Southeast Los Angeles CPA



## Section II-1. LAND USE REGULATIONS

- A. **Use.** Any new use or change of use shall be subject to the use regulations set forth in Table II-1 and the regulations below. Uses are controlled by the underlying zoning and the LAMC except where modified in Table II-1 and the regulations in this Section.
- B. **Existing Uses.** Existing uses made non-conforming by this CPIO, shall comply with LAMC Section 12.23.
- C. **Neighborhood-Serving Uses, Subareas A and B.** In Subareas A and B, in the C2 zone district, uses shall be limited to those permitted in the C1.5 zone, as well as, bakeries, bike sales and repair, charitable institutions, Community Facilities, medical and dental clinics, performing arts schools, opticians, and tutoring centers.
- D. **Ground Floor Commercial, Subarea D.** In Subarea D, all uses in the Ground Floor are prohibited except for Commercial Uses and residential lobbies.

**TABLE II-1:  
USE REGULATIONS**

Subareas: A: Neighborhood-Serving Corridor, B: Parkway Corridor, C: General Corridor, D: Commercial Corridor			
Use	Regulation	Applicable Subarea	Exemptions/Clarifications
<b>Alcohol Sales, Off-Site</b>	Not more than one establishment is permitted within a ½ mile (2,640 linear foot) radius of another Off-Site Alcohol Sales use. <sup>1</sup>	A, B, C, D	<ul style="list-style-type: none"> <li>• Full-Service Grocery Stores and Full-Service Drug Stores are exempt.</li> <li>• Full-Service Grocery Stores and Full-Service Drug Stores that sell alcohol shall be included in the ½ mile radius calculation for other new Off-Site Alcohol Sales requests.</li> <li>• This use is also expressed as Off-Site Alcohol Sales.</li> </ul>
<b>Auto-Related Use</b>	Not more than one establishment is permitted within a ½ mile (2,640 linear foot) radius of another Auto-Related Use. <sup>1</sup>	C	<ul style="list-style-type: none"> <li>• Expansion, re-modeling, replacement of existing Auto-Related Uses, or inclusion of other accessory uses shall be allowed provided that such changes comply with the development standards of this CPIO and are allowed by the underlying zone.</li> <li>• Multiple Auto-Related Uses or accessory Auto-Related Uses are allowed when combined within the same lot or parcel of an existing Auto-Related Use.</li> </ul>
	Prohibited.	A, B	
<b>Check Cashing Facility</b>	Not more than one establishment is permitted within a ½ mile (2,640 linear foot) radius of another Check Cashing Facility. <sup>1</sup>	C, D	
	Prohibited.	A, B	

Use	Regulation	Applicable Subarea	Exemptions/Clarifications
<b>Freestanding Restaurant with Drive-Through</b>	Not more than one establishment is permitted within a ½ mile (2,640 linear foot) radius of another Freestanding Restaurant with Drive-Through use. <sup>1</sup>	A, B, C	<ul style="list-style-type: none"> <li>Expansion, re-modeling, rebuilding or replacement of existing establishments shall be exempt provided there is no change of use and all work complies with the development standards of this CPIO District.</li> </ul>
	No Freestanding Restaurant with Drive-Through is allowed abutting, or across the street, alley or intersection of, a school.	A, B, C, D	<ul style="list-style-type: none"> <li>'School' shall include elementary, middle or high schools, including charter and magnet schools.</li> <li>Expansion, re-modeling or replacement of existing establishments shall be exempt provided there is no change of use and all work complies with the development standards of this CPIO District.</li> </ul>
<b>Gun Shop</b>	Not more than one establishment is permitted within a ½ mile (2,640 linear foot) radius of another Gun Shop. <sup>1</sup>	C, D	
	Prohibited.	A, B	
<b>Motel</b>	Not more than one establishment is permitted within a ½ mile (2,640 linear foot) radius of another Motel. <sup>1</sup>	C, D	
	Prohibited.	A, B	
<b>Pawn Shop</b>	Not more than one establishment is permitted within a ½ mile (2,640 linear foot) radius of another Pawn Shop. <sup>1</sup>	C, D	
	Prohibited.	A, B	

**Subareas:** A: Neighborhood-Serving Corridor, B: Parkway Corridor, C: General Corridor, D: Commercial Corridor

Use	Regulation	Applicable Subarea	Exceptions/Clarifications
<b>Payday Lender</b>	Not more than one establishment is permitted within a ½ mile (2,640 linear foot) radius of another Payday Lender. <sup>1</sup>	C, D	
	Prohibited.	A, B	
<b>Public Self Storage</b>	Not more than one establishment is permitted within a ½ mile (2,640 linear foot) radius of another Public Self Storage use. <sup>1</sup>	C, D	
	Prohibited.	A, B	
<b>Recycling Collection</b>	Not more than one establishment is permitted within a ½ mile (2,640 linear foot) radius of another Recycling Collection use. <sup>1</sup>	C, D	
	Prohibited.	A, B	
<b>100 percent Residential</b>	Prohibited.	D	This prohibition includes live/work units.
<b>Smoke/Vapor Shops</b>	Not more than one establishment is permitted within a ½ mile (2,640 linear foot) radius of another Smoke/Vapor Shop use. <sup>1</sup>	A, B, C, D	

<sup>1</sup> Distance shall be measured from the center point of the front lot line of the subject parcel to the nearest property line of any parcel containing the same use.

## Section II-2. DEVELOPMENT STANDARDS

All Projects in the Corridors Subareas are subject to the following development standards:

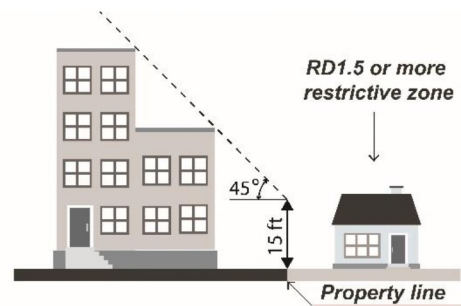
**A. Building Height.** In addition to any regulations set forth by the underlying zone and the LAMC, Projects with new construction or additions shall comply with the following height regulations:

**1. Ground Floor Height.**

- (a) The Ground Floor shall have a minimum height of 14 feet, measured from the finished floor to the underside of the structural floor or roof above.
- (b) For Projects with an Active Floor Area, the Ground Floor shall have a minimum height of 11 feet, measured from the finished floor to the finished ceiling.

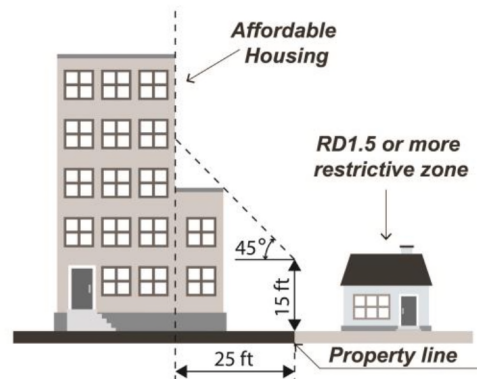
**2. Transition to Residential.**

- (a) Where a parcel is either abutting or across an alley from a property in the RD1.5 or more restrictive zone, the building height shall be stepped-back within a 45 degree angle as measured 15 feet above grade at the property line of the lot in the more restrictive zone.



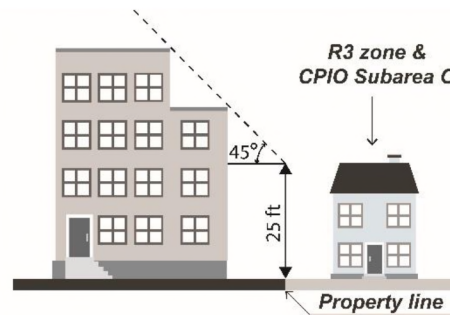
\*Figures are not to scale, illustrative only and not regulatory.

- (b) For all CPIO Affordable Housing Projects, Density Bonus Projects and TOC Projects, that are either abutting or across an alley from a property in the RD1.5 or more restrictive zone, the required height transition applies only to the first 25 feet of depth as measured from the property line of the lot in the more restrictive zone.



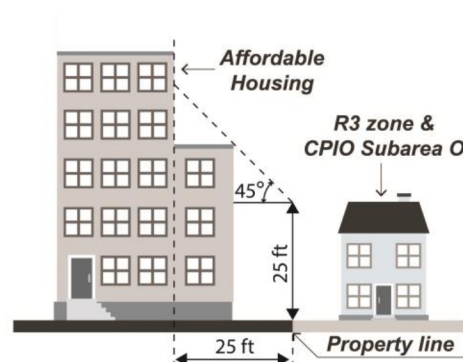
\*Figures are not to scale, illustrative only and not regulatory.

- (c) When a parcel is either abutting or across an alley from a property that is both in the R3 zone and is in Subarea O of the CPIO, the building height shall be stepped-back within a 45 degree angle as measured 25 feet above grade at the property line of the lot in the R3 zone.



\*Figures are not to scale, illustrative only and not regulatory.

- (d) For all CPIO Affordable Housing Projects, Density Bonus Projects, and TOC Projects located on a parcel that is either abutting or across an alley from a property that is both in the R3 zone and is in Subarea O of the CPIO District, the required height transition applies only to the first 25 feet of depth as measured from the property line of the lot in the more restrictive zone.



\*Figures are not to scale, illustrative only and not regulatory.

3. **Adjustments.** The height regulations in this Section II-2.A shall not be eligible for a CPIO Adjustment.

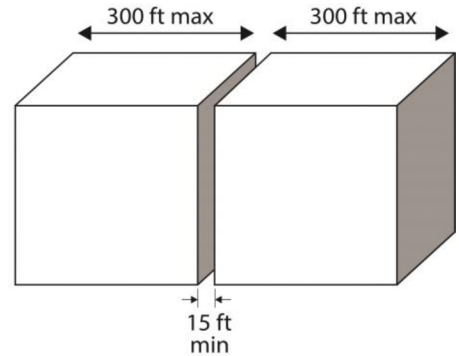
**B. Building Density.** In addition to any regulations set forth by the underlying zone and the LAMC, Residential Projects shall not exceed a density of 1 unit per 800 square feet of lot area (1/800), except as follows:

1. In Subareas A, C and D, Density Bonus Projects or TOC Projects may utilize a Base density of 1 unit per 400 square feet of lot area (1/400).
2. In Subarea B, Density Bonus Projects or TOC Projects that are 100 percent residential may utilize a Base density of 1 unit per 400 square feet of lot area (1/400).
3. The density regulations in this Subsection 1 shall not be eligible for a CPIO Adjustment.

**C. Building Disposition.** In addition to any regulations set forth by the underlying zone and the LAMC, Projects with new construction or additions shall comply with the following disposition regulations:

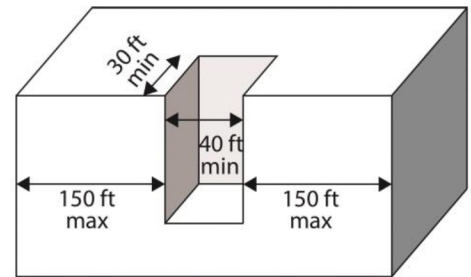
1. **Street Wall.** Any street facing façade of a Project where the cumulative total exceeds 300 feet in length shall comply with either subsection (a) or (b) below:

- (a) Design the Project as separate buildings, not to exceed a maximum of 300 feet in length, separated by passageways that are open to the sky from sidewalk grade and are at least a minimum of 15 feet wide (separate buildings may be built upon the same subterranean parking structure); or



\*Figures are not to scale, illustrative only and not regulatory.

- (b) Provide a continuous building base (1 to 3 stories) with upper floor volumes that do not exceed a maximum of 150 feet in length and separated by courtyards open to the sky that are at least a minimum of 40 feet wide and at least a minimum of 30 feet in depth, as measured from the street facing façade.



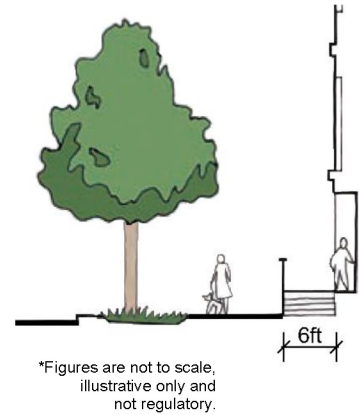
\*Figures are not to scale, illustrative only and not regulatory.

2. **Primary Frontage.** In Subarea A, for all Projects, except 100 percent residential Projects, the Ground Floor shall be located along the Primary Lot Line for at least 75 percent of the length of the Primary Frontage, up to a minimum height of 12 feet as measured from the abutting sidewalk grade or right of way except that the Ground Floor may be set back up to 20 feet along the Primary Frontage to the extent necessary to accommodate Pedestrian Amenities.
3. **Lot Coverage.** In Subarea A, Projects shall provide a minimum lot coverage of 30 percent. Lot coverage shall be the cumulative total of the Building Footprint of all buildings on the lot including those that currently exist and will remain on the site as well as new buildings.

4. **Landscape Buffer.** A 5-foot landscape buffer, inclusive of any required setbacks, shall be provided between the Project site and any abutting lot zoned RD1.5 or a more restrictive zone. Landscaping that is drought tolerant, evergreen, and capable of growing to a height of 10 feet shall be utilized, and a decorative masonry wall a minimum of six feet and a maximum of eight feet in height shall be constructed along the shared property line.

5. **Residential Setbacks.**

- (a) For Projects that consists exclusively of residential dwelling units with no Active Floor Area, any street facing frontage shall be set back at least six feet and not more than ten feet from the property line. This setback area shall be improved with landscaping, Pedestrian Amenities or a combination thereof.



- (b) For Mixed-Use Projects, no setback requirements shall apply to any portion of a street facing building frontage used for residential uses.

**D. Building Design.** In addition to any regulations set forth by the underlying zone and the LAMC, Projects with new construction or additions shall comply with the following building design regulations:

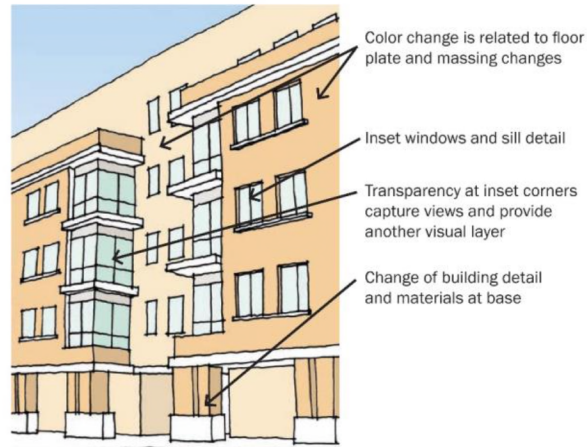
1. **Glazing.**

- (a) In Subareas B, C and D, the Ground Floor Primary Frontage shall have a minimum of 25 percent clear transparent glazing (such as, windows and doors). The other floors of the Primary Frontage shall have a minimum of 15 percent clear transparent glazing, inclusive of all of those floors. All other building facades facing public streets shall have a minimum of 15 percent clear transparent glazing.
- (b) In Subarea A, the Ground Floor Primary Frontage shall have a minimum of 50 percent clear transparent glazing (such as, windows and doors). The other floors of the Primary Frontage shall have a minimum of 15 percent clear transparent glazing, inclusive of all of those floors. All other building facades facing public streets shall have a minimum of 15 percent clear transparent glazing.

2. **Articulation.** All exterior building walls shall provide a break in the plane, or a change in material, at least every 20 feet in horizontal length and every 15 feet in vertical length, created by an articulation or architectural detail, such as:

- (a) Ground Floor storefront bays;
- (b) A change in plane of at least 18 inches;
- (c) Windows that are recessed at least 2 inches, or that project such as bays;

- (d) Building overhangs, such as canopies or eaves;
- (e) Terraces, balconies, porches or cantilevered designs;
- (f) Wood accents and wood trim for windows and doors;
- (g) Varying roof forms and heights; and
- (h) Other Architectural Features or building materials that create a visual break (such as, stucco reveals that are a minimum of 2 inches in depth).



\*Figures are not to scale, illustrative only and not regulatory.

3. **Projects Near Freeways.** Projects that are within 100 feet of a freeway right-of-way, shall comply with the following:
  - (a) Balconies are not permitted on any portion of a building that is within 100 feet of a freeway right-of-way.
  - (b) Projects that abut a freeway right-of-way shall provide a minimum 5-foot landscaped setback from the freeway right-of-way property line. The landscaping shall be drought tolerant, evergreen, and capable of growing to a height of 10 feet at maturity. A decorative masonry wall a minimum of six feet and a maximum of eight feet in height shall be constructed along the property line.
  
4. **Active Floor Area.** In Subarea A, for all Projects except 100 percent residential Projects, the Ground Floor of the Primary Frontage shall incorporate Active Floor Area, Pedestrian Amenities, or a combination of both, along at least 75 percent of the Primary Frontage to a depth of at least 25 feet (excluding areas used for vehicular access).

5. **Street-Oriented Entrance.**

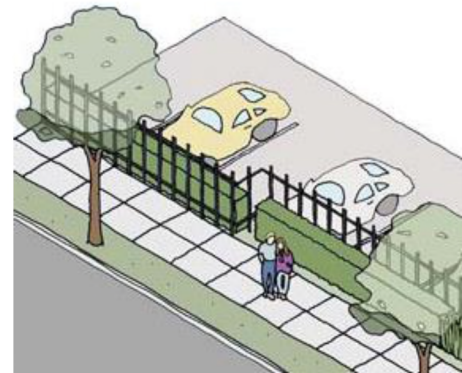
- (a) Projects shall provide a Street-Oriented Entrance. Street-Oriented Entrances need not be parallel to the Primary Lot Line, provided that they are no more than 20 feet from the Primary Lot Line and augmented by entrance forecourts or other design features that establish a visual connection to the Primary Lot Line.
- (b) In the case of non-residential Projects, Street-Oriented Entrances shall be accessible during business hours and shall be no more than three feet above or below the grade of the abutting public sidewalk grade.

6. **Building Materials.**

- (a) Projects shall utilize two or more high-quality building materials and treatments on building exteriors such as brushed aluminum, brick, finished wood, or “Santa Barbara” smooth finish stucco.
- (b) The following materials are prohibited: Styrofoam plant-ons and rough texture stucco (such as, lace, heavy dash, tunnel dash, heavy sand float).
- (c) The Primary Frontage may be comprised of no more than 80 percent stucco.

E. **Parking Design.** In addition to any regulations set forth by the underlying zone and the LAMC, Projects with new construction or additions shall comply with the following parking design regulations:

1. **Surface Parking Screening.** Where permitted, surface parking lots that abut public sidewalks shall provide a three-foot landscaped buffer, and a three and a half foot high decorative wall and/or hedge along the property line facing a street intended to screen headlights. The wall and/or hedge shall provide pedestrian entrances (separate from vehicular entrances) from the public sidewalk.



\*Figures are not to scale, illustrative only and not regulatory.

2. **Ground Floor Parking Level.** Wherever at-grade or above ground parking is to be provided within a building’s Ground Floor level fronting a public street (excluding alleys), the entire building shall be set back six feet from the adjacent public street and the setback shall be improved with diverse landscaping that is comprised of two or more plant types that screens the Ground Floor parking area up to a height of 10 feet. This requirement does not apply to that portion of the building where internal parking structures are buffered by habitable floor area on the Ground Floor such as retail space or a community room.

3. **Parking Structure Façades.** For stand-alone parking structures, provide an external skin or other material consistent with or complementary to the overall design of the building intended to improve the building's appearance over the basic concrete structure of ramps, walls and columns on all visible façades.

Examples of appropriate skin material include heavy-gauge metal screen, pre-cast concrete panels, laminated glass, and photovoltaic panels.

4. **Shade Trees.** Surface parking lots shall have at least one tree for every four uncovered parking spaces distributed throughout the parking lot to shade the parking area at maturity. A minimum of half of the trees planted shall be trees of no less than a 24-inch box tree or a 15 gallon tree. Palm trees shall not be used to meet this requirement.
  5. **Pedestrian Walkway.** Projects shall provide, within the surface-parking lot area, at least one centrally located pedestrian walkway that runs the length of the parking lot from the sidewalk to the building entrance and is separated from the parking lot by landscaping and shade trees.
  6. **Parking Lot Location, Subarea A.** In Subarea A, surface parking areas shall not be located between the Primary Lot Line and the Primary Frontage of a building. Surface parking shall be located to the rear or side of buildings. Parking can also be enclosed within a structure, or located entirely below grade. Below grade structures can occupy the entire footprint of a lot.
  7. **Vehicular Access, Subarea A.** In Subarea A, new buildings shall provide vehicular access from an alley or side street when available. Vehicular access from the Primary Frontage is prohibited unless the LADOT determines that no other reasonable alternative exists.
  8. **Curb Cuts, Subareas A and B.** In Subareas A and B, curb cuts shall be limited to the minimum number permitted as determined by LADOT and parking/loading entries into buildings shall be limited to the minimum number required and the minimum width permitted by the LAMC.
- F. **Prohibited Signs.** In addition to any regulations set forth by the underlying zone and the LAMC, the following types of signs are prohibited: pole signs; illuminated architectural canopy signs; Feather Signs; digital displays; and Canister/Can/Cabinet Signs.
- G. **Equipment, Fencing, and Utilities.** In addition to any regulations set forth by the underlying zone and the LAMC, Projects with new construction and additions shall comply with the following equipment and utility regulations:
1. **Security Devices.**
    - (a) Any interior roll-down doors and security grilles must be at least 75 percent transparent (open), retractable, and designed to be fully screened from view during business hours.

- (b) The following security devices are always prohibited:
  - (i) Permanently affixed exterior security grilles or bars.
  - (ii) Exterior accordion (or scissor) gates.
  - (iii) Exterior roll-down doors that are less than 75 percent transparent.
  - (iv) Exterior roll-down doors that have exterior housing that is visible from the sidewalk.

- 2. **Mechanical Equipment.** Mechanical equipment shall be screened from public view using non-reflective materials or other materials consistent with or complementary to the overall design of the building.
- 3. **Fencing.** Chain link fencing (with or without slats), corrugated metal, and barbed/razor wire is prohibited along a Primary Frontage or where a parcel is either directly adjacent to or across an alley from a property in the RD1.5 zone (or a more restrictive zone) or a property containing a Community Facility.
- 4. **Refuse Enclosures.** Areas where trash and recycling containers are stored outside shall be fully enclosed, including roofing, with solid masonry walls or other similar materials that have been determined to prevent the release of refuse odors.

**H. Auto-Related Use and New Franchise Automobile Sales Standards.** In addition to any regulations set forth by the underlying zone and the LAMC, Projects with Auto-Related Uses and New Franchise Automobile Sales Uses shall comply with the following regulations.

- 1. A solid masonry wall for security and visual screening shall be provided at the property line where a parcel is either directly adjacent to or across an alley from a residentially zoned property or a property containing a Community Facility.
- 2. No permit shall be issued until a covenant has been recorded on the subject property in a form and manner approved by the Department of City Planning, for the life of the use, demonstrating that the following requirements shall apply:
  - (a) All actual repair or installation work shall be conducted within an enclosed building.
  - (b) All vehicles undergoing, or awaiting, repair or pick-up shall be parked on-site. Overnight storage of vehicles shall be parked on-site. No on-street parking spaces shall be utilized for storage or parking of vehicles. Storage of or parking of vehicles which require repair 30 days or more is prohibited.
  - (c) Equipment or parts removed from vehicles during the repair process shall be stored indoors or shall be deposited in an approved covered outdoor collection receptacle for appropriate off-site disposal.

- (d) All loading and un-loading of vehicles shall be done on-site.

**Section II-3. PARKING REGULATIONS**

- A. Required Parking Spaces.** The required number of parking spaces for Projects with new construction shall be set forth in the applicable provisions of the LAMC except as provided in Table II-2, and as set forth below.
  - 1. **Eligible Historic Resources.** That portion of a Project involving the Restoration or Rehabilitation of a Designated or Eligible Historic Resource shall be exempt from all off-street parking requirements provided that it does not include an addition of more than 500 square feet or involve a demolition to more than 10 percent of the original building envelope.
  - 2. **Parking Incentives.** Identified commercial uses may reduce the required parking as set forth in Table II-2.
- B. Change of Use, Subarea A.** In Subarea A, no additional parking shall be required for a change of use in an existing building from a non-residential use to any non-residential use permitted in the C1.5 zone.

**TABLE II-2:  
PARKING REGULATIONS**

Subareas: A: Neighborhood-Serving Corridor, C: General Corridor, D: Commercial Corridor	
Parking Standards	Subarea
Required parking for Targeted Commercial Uses may be reduced by a maximum of 25%.	A, C, D
In new buildings, Sit-Down Restaurants of any size may provide a minimum of 1 parking space per 500 square feet of floor area.	A, C, D

# CHAPTER III – TOD SUBAREAS

## TRANSIT-ORIENTED DEVELOPMENT (“TOD”) SUBAREAS

- E – TOD Low
- F – TOD Medium
- G – TOD High
- H – TOD Regional

### OVERVIEW

TOD Subareas E, F, G, and H promote walkable, vibrant, attractive and complete transit centers that provide a greater mix of housing for a range of incomes, jobs, goods and services, and that enhance community identity as described in Sections I-2 and consistent with the purposes set forth in Section I-3.

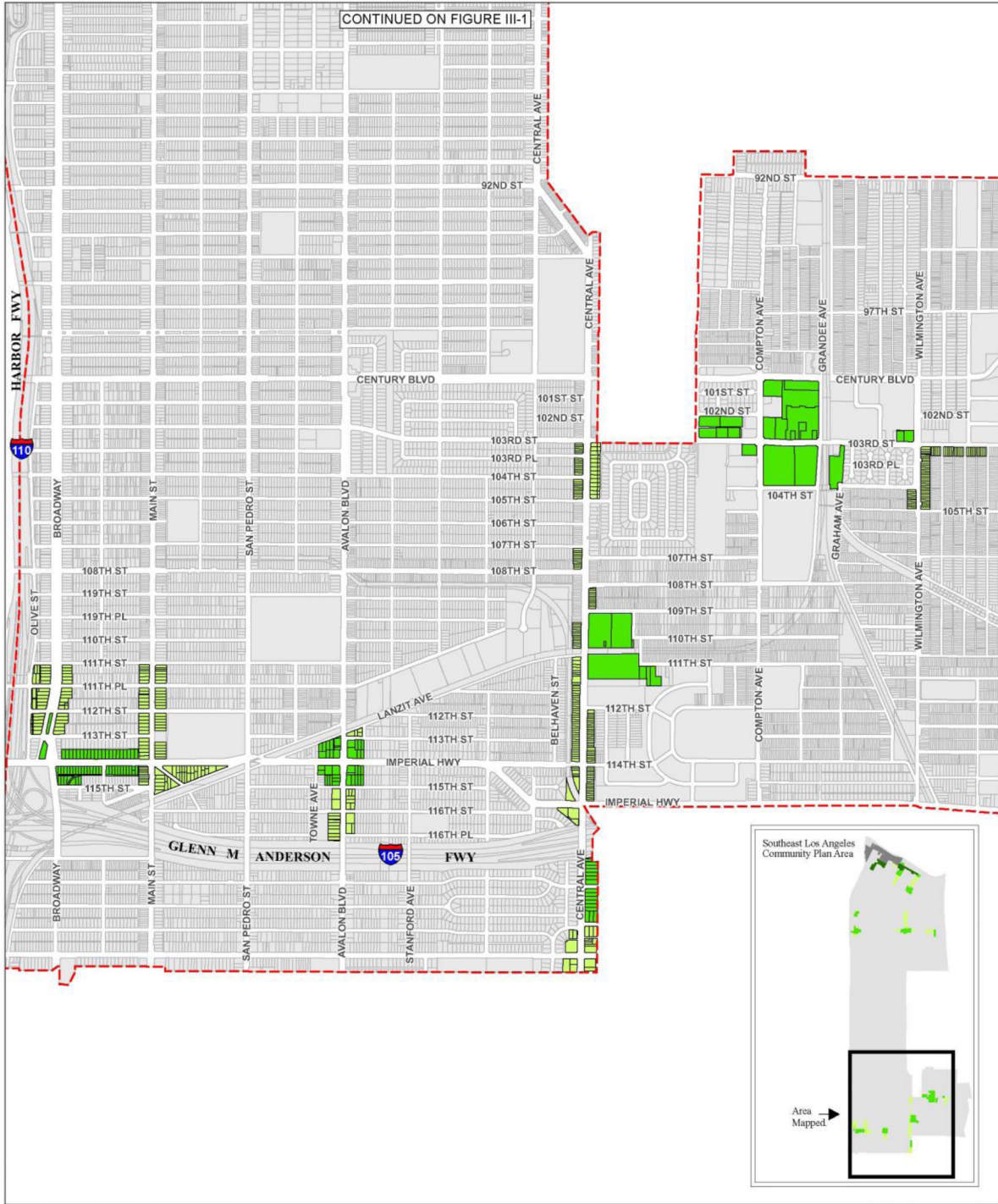
The intent of the supplemental development regulations in this Chapter is to provide for well-designed, pedestrian-oriented projects that are appropriate to the scale and context of each specific transit neighborhood. Use regulations promote the establishment of much needed uses (such as Full-Service Grocery Stores and Banks), as well as incentivize 100 percent affordable housing and mixed-income housing projects to be built near transit. All Projects within a TOD Subarea (See Figures III-1 and III-2) shall comply with the applicable supplemental development regulations in this Chapter III.



**FIGURE III-1. TOD SUBAREAS**

- Subarea E - TOD Low
- Subarea F - TOD Medium
- Subarea G - TOD High
- Subarea H - TOD Regional
- Southeast Los Angeles CPA





## Section III-1. APPLICABILITY

**A. Purpose.** The purposes of this section are (1) to encourage the construction of 100 percent affordable housing projects and mixed-income housing projects by providing specific density, FAR and height bonuses and streamlined procedures to approve said projects; (2) to foster project designs that are pedestrian oriented; and (3) to improve the quality of new development as well as its compatibility with existing neighborhoods through the implementation of supplemental development regulations. By providing bonuses and streamlined procedures for specified affordable housing projects the section intends to provide additional tools to promote affordable housing while not undermining the implementation of the state density bonus law codified in Government Code Sections 65915-65918 and LAMC Section 12.22.A.25.

**B. Density, Height, and FAR Bonuses.** Projects that obtain density, height or FAR bonuses, incentives, waivers or concessions pursuant to LAMC Sections 12.22.A.25, 12.22.A.31 or any other State or local program, including Government Code Sections 65915-65918, may not use any CPIO Bonus or incentive unless otherwise expressly provided in this Southeast Los Angeles CPIO District.

### **C. TOC Projects or Density Bonus Projects.**

1. **Base.** The Base density, Base height and Base FAR for TOC Projects or Density Bonus Projects are set forth in Section III-3 and Table III-2.
2. **CPIO Bonuses.** Unless expressly provided otherwise in this CPIO District, no CPIO Bonuses are available for TOC Projects or Density Bonus Projects.

### **D. CPIO Affordable Housing Projects.**

1. **Base.** The applicable Base density, Base height and Base FAR for all CPIO Affordable Housing Projects are as set forth in Section III-3 and Table III-2.
2. **Bonuses.** CPIO Affordable Housing Projects may utilize CPIO Bonuses as provided in Section III-3 and Table III-2.
3. **Additional Incentives.** If eligible for CPIO Bonuses, then, in addition to the CPIO Bonuses above, a CPIO Affordable Housing Project may utilize up to two additional incentives from the menu of options listed below, provided that the landscaping for the Project is sufficient to qualify for the number of landscape points equivalent to 10 percent or more than otherwise required by LAMC Section 12.40 and Landscape Ordinance Guidelines "O":
  - (a) **Yard/Setback.** Up to 20 percent decrease in the required width or depth of any individual yard or setback except along any property line that abuts a R1 or more restrictively zoned property.
  - (b) **Lot Coverage.** Up to 20 percent increase in lot coverage limits.

- (c) **Lot Width.** Up to 20 percent decrease from a lot width requirement.
  - (d) **Open Space.** Up to 20 percent decrease from an open space requirement.
4. **Administrative Clearance.** CPIO Affordable Housing Projects that utilize CPIO Bonuses and incentives in Subsections 2 and 3, above, and that comply with all other requirements of the CPIO, shall be approved with an Administrative Clearance pursuant to Section I-6.C.2 of this ordinance.
5. **Replacement Housing.** Projects that qualify as a CPIO Affordable Housing Project must meet any applicable housing replacement requirements of Government Code Section 65915(c)(3), (as it may be amended from time to time), subject to verification by HCIDLA prior to the issuance of any building permit. Replacement housing units required per this subsection may also count towards any required Restricted Affordable Units.
6. **Affordability Covenants.** Prior to issuance of an Administrative Clearance for a CPIO Affordable Housing Project, the following shall apply:
- (a) For Projects that provide Lower, Very Low and Extremely Low Income Housing, a covenant shall be recorded in a form and manner approved by HCIDLA, guaranteeing that the affordability criteria will be observed for at least 55 years from the issuance of the certificate of occupancy or for a longer period of time if required by the construction or mortgage financing assistance program, mortgage assistance program, or rental subsidy program, or any other government requirement.
  - (b) Any covenant described in this paragraph must provide for a private right of enforcement by the City, any tenant, or owner of any building to which a covenant and agreement applies.
7. **Targeted Commercial Use Covenants.** Prior to issuance of an Administrative Clearance for a CPIO Affordable Housing Project that includes a Targeted Commercial Use, the following shall apply:
- (a) A covenant acceptable to the City Administrative Officer and the Department of City Planning shall be recorded guaranteeing that the subject Targeted Commercial Use, or another Targeted Commercial Use, or combination of Targeted Commercial Uses, applicable to the subarea and with the commensurate Bonus increase, will remain for at least 30 years from the issuance of the certificate of occupancy.
  - (b) If the duration of the covenants provided for in Section III-1.D.7(a) directly above conflicts with the duration for any other government requirement, the longest duration shall control.
  - (c) Any covenant described in this paragraph must provide for a private right of enforcement by the City, any tenant, or owner of any building to which a covenant and agreement applies.

- (d) Any covenant shall be prepared and recorded in a form and manner approved by the Department of City Planning to ensure that the obligations are binding against all successors in interest to the real property.
8. **Unit Quality.** Affordable dwelling units within CPIO Mixed-Income Housing Projects shall be no less than 90 percent of the average square footage of market-rate dwelling units with the same number of bedrooms, be interspersed throughout the development, and shall have access to the same amenities and use of the same entrances. Building materials shall be consistent throughout.
- E. 100 percent Commercial Projects.** Projects with new construction that include no residential uses shall comply with the following:
- 1. **Base.** The Base height, including the minimum height, and Base FAR for 100 percent Commercial Projects are set forth in Section III-3 and Table III-3.
  - 2. **Bonuses.** One hundred (100) percent Commercial Projects that include Targeted Commercial Uses may use CPIO Bonuses for height and FAR as provided in Sections III-3.A.2 and III-3.B.2 and in Table III-3.
  - 3. **Administrative Clearance.** One hundred (100) percent Commercial Projects that comply with all applicable supplemental development regulations, and that comply with all other requirements of the CPIO, shall be approved with an Administrative Clearance pursuant to Section I-6.C.2.
  - 4. **Targeted Commercial Use Covenants.** Prior to issuance of an Administrative Clearance for a 100 percent Commercial Project that includes a Targeted Commercial Use, the following shall apply:
    - (a) A covenant acceptable to the City Administrative Officer and the Department of City Planning shall be recorded guaranteeing that the subject Targeted Commercial Use, or another Targeted Commercial Use, or combination of Targeted Commercial Uses, applicable to the subarea and with the commensurate Bonus increase, will remain for at least 30 years from the issuance of the certificate of occupancy.
    - (b) If the duration of covenants provided for in Section III-1.E.4(a) directly above conflicts with the duration for any other government requirement, the longest duration shall control.
    - (c) Any covenant described in this paragraph must provide for a private right of enforcement by the City, any tenant, or owner of any building to which a covenant and agreement applies.
    - (d) Any covenant shall be prepared and recorded in a form and manner approved by the Department of City Planning to ensure that the obligations are binding against all successors in interest to the real property.

## **Section III-2. LAND USE REGULATIONS**

**A. Use.** Any new use or change of use shall be subject to the use regulations set forth in Table III-1 below.

**B. Existing Uses.** Non-conforming uses, including uses made non-conforming by this CPIO, shall comply with LAMC Section 12.23.

**TABLE III-1:  
USE REGULATIONS**

<b>Subarea Types:</b> E: TOD Low, F: TOD Medium, G: TOD High, H: TOD Regional			
<b>Use</b>	<b>Regulation</b>	<b>Applicable Subareas</b>	<b>Exemptions/Clarifications</b>
<b>Alcohol Sales, Off-Site</b>	Not more than one establishment is permitted within a ½ mile (2,640 linear foot) radius of another Off-Site Alcohol Sales use. <sup>1, 2</sup>	E, F, G, H	<ul style="list-style-type: none"> <li>• Full-Service Grocery Stores and Full-Service Drug Stores are exempt.</li> <li>• Full-Service Grocery Stores and Full-Service Drug Stores that sell alcohol shall be included in the ½ mile radius calculation for other new Off-Site Alcohol Sales requests.</li> <li>• This term is also expressed as Off-Site Alcohol Sales</li> </ul>
<b>Auto-Related Uses</b>	Prohibited.	E, F, G, H	<ul style="list-style-type: none"> <li>• Expansion, re-modeling, replacement of existing Auto-Related Uses, or new accessory uses are exempt from the prohibition provided the Project complies with all applicable development standards of this CPIO and the Project is allowed by the underlying zone.</li> <li>• New Auto-Related Uses or accessory Auto-Related Uses are exempt from the prohibition when the new uses are combined within the same lot or parcel of an existing Auto-Related Use.</li> </ul>
<b>Check Cashing Facilities</b>	Prohibited.	E, F, G, H	
<b>Drive-Through Establishments</b>	Prohibited.	E, F, G, H	
<b>Gun Shops</b>	Prohibited.	E, F, G, H	
<b>Motels</b>	Prohibited.	E, F, G, H	
<b>Pawn Shops</b>	Prohibited.	E, F, G, H	
<b>Payday Lenders</b>	Prohibited.	E, F, G, H	

**Subareas:** A: Neighborhood-Serving Corridor, B: Parkway Corridor, C: General Corridor, D: Commercial Corridor

Use	Regulation	Applicable Subarea	Exceptions/Clarifications
<b>Public Self Storage</b>	Prohibited.	E, F, G, H	
<b>Recycling Collection</b>	Prohibited.	E, F, G, H	
<b>100% Residential Uses</b>	Prohibited.	G, H	This prohibition includes live/work units.
<b>Smoke/Vapor Shops</b>	Not more than one establishment is permitted within a ½ mile (2,640 linear foot) radius of another Smoke/Vapor Shop use. <sup>1</sup>	E	
	Prohibited.	F, G, H	
<b>Swap Meets</b>	Prohibited.	E, F, G, H	
<sup>1</sup> Distance shall be measured from the center point of the front lot line of the subject parcel to the nearest property line of any parcel containing the same use.			

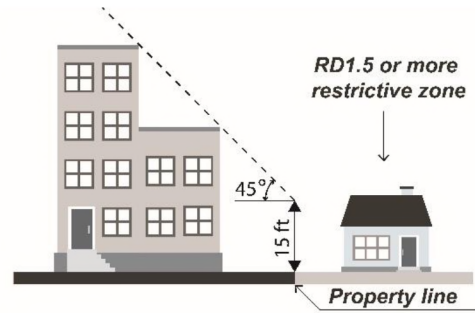
### Section III-3. DEVELOPMENT STANDARDS

All Projects in the TOD Subareas are subject to the following development standards:

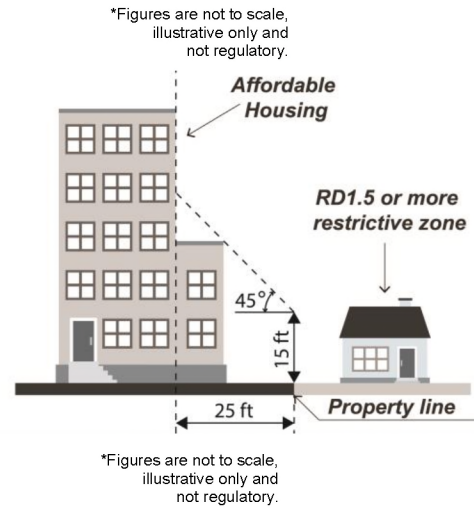
- A. Building Height.** In addition to any regulations set forth by the underlying zone and the LAMC, Projects with new construction or additions shall comply with the following height regulations:
1. **Ground Floor Height.** The following height restrictions apply:
    - (a) The Ground Floor shall have a minimum height of 14 feet, measured from the finished floor to the underside of the structural floor or roof above.
    - (b) For Projects with an Active Floor Area, the Ground Floor shall have a minimum height of 11 feet, measured from the finished floor to the finished ceiling.
  2. **Base Height.** The Base height, including any minimum height, shall be set forth in Table III-2 and Table III-3.
  3. **Bonuses for Height.** The following Bonuses for height apply:
    - (a) For a Density Bonus Project or a TOC Project, any incentive for height provided through the Density Bonus or TOC program shall be in addition to the Base height set forth in Table III-2.
    - (b) For a CPIO Affordable Housing Project, the Base height and Bonus height are set forth in Table III-2.
    - (c) For a 100 percent commercial project, the minimum height, Base height and the Bonus Height shall be as set forth in Table III-3, except as follows:
      - (i) 100 percent commercial projects that include one or more Targeted Commercial Use(s) may exceed the Base height set forth in Table III-3 by one additional story (not to exceed 15 feet).
      - (ii) Child care facility and Sit-Down Restaurant uses shall not be eligible for the additional story unless the proposed use exceeds 5,000 sq. feet.

4. **Transition to Residential.** The following height restrictions apply:

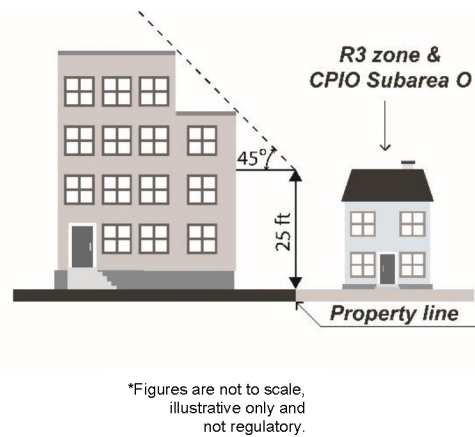
- (a) Where a parcel is either abutting or across an alley from a property in the RD1.5 or more restrictive zone, the building height shall be stepped-back within a 45 degree angle as measured 15 feet above grade at the property line of the lot in the more restrictive zone.



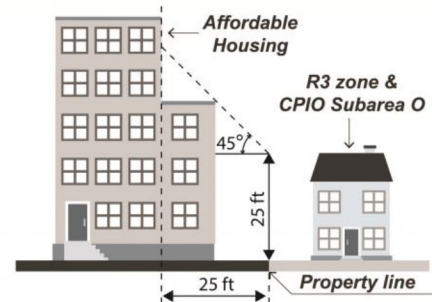
- (b) For all CPIO Affordable Housing Projects, Density Bonus Projects or TOC Projects, that are either abutting or across an alley from a property in the RD1.5 or more restrictive zone, the required height transition applies only to the first 25 feet of depth as measured from the property line of the lot in the more restrictive zone.



- (c) When a parcel is either abutting or across an alley from a property that is both in the R3 zone and is in Subarea O of the CPIO, the building height shall be stepped-back within a 45 degree angle as measured 25 feet above grade at the property line of the lot in the R3 zone.



- (d) For all CPIO Affordable Housing Projects, Density Bonus Projects and TOC Projects, when on a parcel that is either abutting or across an alley from a property that is both in the R3 zone and is in Subarea O of the CPIO, the required height transition applies only to the first 25 feet of depth as measured from the property line of the lot in the more restrictive zone.



\*Figures are not to scale, illustrative only and not regulatory.

5. **Architectural Features.** Architectural Features may exceed the allowable maximum height, including the maximum height granted through any CPIO Bonus or any bonus or incentive given under LAMC Section 12.22.A.25 or 12.22.A.31, by up to 20 percent.
  6. **Rooftop Structures and Equipment.** Rooftop structures, equipment and improvements may exceed the maximum building height when authorized pursuant to LAMC Section 12.21.1.B.3 (a) provided the structure, equipment or improvement is screened from public view using non-reflective materials or otherwise made compatible with the overall design of the building.
  7. **Subarea H (TOD Regional).** Projects that obtain a conditional use permit pursuant to LAMC Section 12.24 U.26 to request additional height in excess of the height regulations in this Section III-3 A shall not be required to obtain a CPIO Exception.
  8. **Adjustments.** The height regulations in this Section III-3.A shall not be eligible for a CPIO Adjustment.
- B. Building Density & Floor Area Ratio (FAR).** In addition to any regulations set forth by the underlying zone and the LAMC, Projects shall comply with the following density and FAR regulations:
1. **Residential Density.** The Base residential density shall be as provided in Table III-2, and as modified below:
    - (a) For a Density Bonus Project or a TOC Project, the Base density shall be 1 unit per 800 square feet of lot area, except that a Density Bonus Project or TOC Project that meets or exceeds the affordability percentages of a CPIO Mixed-Income Housing Project, shall use a Base density of 1 unit per 400 square feet of lot area (1/400) in addition to any residential density incentive provided through the Density Bonus or TOC program.

- (b) For a CPIO Affordable Housing Project, the Base density shall be increased from 1 unit per 800 square feet of lot area (1/800) to 1 unit per 300 square feet of lot area (1/300) as set forth in Table III-2.
  - (c) The density regulations in this Section III B.1 shall not be eligible for a CPIO Adjustment.
2. **Floor Area Ratio (FAR).** The maximum building FAR shall be as provided in Tables III-2, and III-3, and is subject to the following:
- (a) For a Density Bonus Project or a TOC Project, any FAR increase provided through those programs shall be added to the Base FAR set forth in Table III-2.
  - (b) A CPIO Affordable Housing Project's Base and Bonus FAR shall be as set forth in Table III-2, except as follows:
    - i. Projects that result in or create a Unified Lot:
      - a. Projects that involve new construction and consolidate two lots to form a Unified Lot that is at least 10,000 square feet are allowed up to a 10 percent increase in FAR.
      - b. Projects that involve new construction and consolidate three or more lots to form a Unified Lot that is at least 15,000 square feet are allowed up to a 15 percent increase in FAR.
      - c. No Project can receive more than one FAR increase related to the creation of one or more Unified Lots.
      - d. The FAR increase provided for Unified Lots cannot exceed the Maximum Allowable Bonus FAR set forth below in subdivision 2(d).
    - ii. Projects that include Publicly Accessible Open Space that are:
      - a. At least 5,000 square feet but less than 10,000 square feet in size, 25 percent of the area devoted to Publicly Accessible Open Space shall be added to the Base FAR provided the Maximum Allowable Bonus FAR set forth below in subdivision 2(d) is not exceeded.
      - b. 10,000 square feet or more, 50 percent of the floor area devoted to Publicly Accessible Open Space shall be added to the Base FAR provided the Maximum Allowable Bonus FAR set forth below in subdivision 2(d) is not exceeded.

- c. No Project can receive more than one FAR increase related to the creation of a Publicly Accessible Open Space.
- (c) For a 100 percent commercial project, the Base FAR and Bonus FAR are set forth in Table III-3.
  - (i) Bonus FAR is allowed for 100 percent commercial projects that include a Targeted Commercial Use, or combination of Targeted Commercial Uses, a Unified Lot, a Publicly Accessible Open Space and/or a Public Plaza as provided below, but cannot exceed the Maximum Allowable Bonus FAR set forth in subdivision 2(d).
  - (ii) The Bonus FAR for Targeted Commercial Uses shall be up to 50 percent of the building floor area devoted to each Targeted Commercial Use.
  - (iii) Projects that result in or create a Unified Lot:
    - a. Projects that involve new construction and that consolidate two lots to form a Unified Lot that is at least 10,000 square feet, are allowed up to a 10 percent increase in FAR.
    - b. Projects that involve new construction that consolidate three lots or more to form a Unified Lot that is at least 15,000 square feet, are allowed up to a 15 percent increase in FAR.
    - c. No Project can receive more than one FAR increase related to the creation of one or more Unified Lots.
  - (iv) Projects that include Publicly Accessible Open Space:
    - a. If the Publicly Accessible Open Space is at least 5,000 sq. ft. but less than 10,000 square feet in size, 25 percent of the floor area devoted to Publicly Accessible Open Space shall be added to the Base FAR but cannot exceed the Maximum Allowable Bonus FAR set forth below in Subdivision 2(d) below.
    - b. If the Publicly Accessible Open Space is 10,000 square feet or more, 50 percent of the floor area devoted to Publicly Accessible Open Space shall be added to the Base FAR but cannot exceed the Maximum Allowable Bonus FAR set forth below in Subdivision 2(d) below.

- c. No Project can receive more than one FAR increase related to the creation of a Publicly Accessible Open Space.
- (v) If a Public Plaza is included, an additional 0.5 Bonus FAR may be obtained. For example, a project with a FAR of 1.5:1 that includes a Public Plaza may increase its FAR to 2.0:1.
- (d) **Maximum Allowable Bonus FAR.** For all Projects except Density Bonus Projects and TOC Projects, the total combined floor area provided under this CPIO shall not exceed the following Maximum Allowable Bonus FAR, inclusive of all incentives and bonuses, as follows:
  - (i) Projects in Subarea E (TOD Low) shall be limited to 3:1;
  - (ii) Projects in Subarea F (TOD Medium) shall be limited to 3.5:1;
  - (iii) Projects in Subarea G (TOD High) shall be limited to 4:1; and
  - (iv) Projects in Subarea H (TOD Regional) shall be limited to 6:1.
- (e) **Adjustments.** The FAR regulations in this Section III B.2 shall not be eligible for a CPIO Adjustment.

**TABLE III-2  
DENSITY, FAR, & HEIGHT  
FOR ALL PROJECTS THAT INCLUDE RESIDENTIAL**

ALL PROJECTS - BASE (Including Density Bonus and TOC)				CPIO AFFORDABLE HOUSING PROJECTS - BONUS				Clarifications	
Subarea	Base Density <sup>1</sup>	Minimum Height	Base Height	Base FAR	Bonus Density	Bonus Height <sup>2</sup>	Bonus FAR <sup>3</sup>		Maximum Allowable Bonus FAR <sup>3</sup>
E (TOD Low)	1/800	N/A	3 Stories / 45 feet	1.5:1	1/300	4 Stories / 60 feet	2:1	up to 3:1	<ul style="list-style-type: none"> <li>Maximum 2:1 FAR shall be reserved for CPIO Mixed-Income Housing Projects.</li> <li>Up to 3:1 FAR for CPIO Mixed-Income Housing Projects that include a TCU, UL and/or PAOS (inclusive of all bonuses and incentives).</li> </ul>
F (TOD Medium)	1/800	2 Stories	4 Stories / 60 feet	1.5:1	1/300	5 Stories / 75 feet	3:1	up to 3.5:1	<ul style="list-style-type: none"> <li>Maximum 3:1 FAR shall be reserved for CPIO 100% Affordable Housing Projects.</li> <li>Up to 3.5:1 FAR for CPIO Affordable Housing Projects that include a TCU, UL and/or PAOS (inclusive of all bonuses and incentives).</li> </ul>
G (TOD High) <sup>1</sup>	1/800	2 Stories	7 Stories / 105 feet	1.5:1	1/300	8 Stories / 120 feet	3.5:1	up to 4:1	<ul style="list-style-type: none"> <li>Up to 4:1 FAR for CPIO Affordable Housing Project that includes a TCU, UL and/or PAOS (inclusive of all bonuses and incentives).</li> </ul>
H (TOD Regional Center)	1/800	2 Stories	12 Stories / 180 feet	2.25:1	No Limit	15 Stories / 225 feet	6:1	up to 6:1	<ul style="list-style-type: none"> <li>Projects may apply for a CUP pursuant to LAMC Sec. 12.24.F. to request additional height.</li> <li>Up to 6:1 FAR for CPIO Affordable Housing Project that include a TCU, UL and/or PAOS (inclusive of all bonuses and incentives).</li> </ul>

<sup>1</sup> Base Density for Density Bonus and TOC Projects that meet certain requirements is 1/400; see Section III-3 B.1(a).

<sup>2</sup> Targeted Commercial Uses see Section III-3 A.3 for bonus height.

<sup>3</sup> Targeted Commercial Uses (TCU), Unified Lot (UL) and/or Publicly Accessible Open Space (PAOS); see Section III-3 B.2 for bonus FAR.

**TABLE III-3:  
FAR AND HEIGHT for 100% COMMERCIAL PROJECTS**

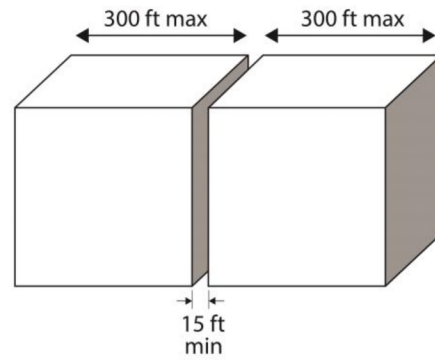
Subarea	Minimum Height	Base Height	Bonus Height <sup>1</sup>	Base FAR	Bonus FAR <sup>2</sup>	Clarifications
E (TOD Low)	N/A	3 Stories / 45 feet	4 Stories / 60 feet	1.5:1	3:1	<ul style="list-style-type: none"> <li>Projects that incorporate select Targeted Commercial Use(s) qualify for 4 story Bonus height.<sup>1</sup></li> <li>Projects that incorporate a Targeted Commercial Use(s), UL, PAOS and/or a PP qualify for up to 3:1 Bonus FAR.</li> </ul>
F (TOD Medium)	2 Stories	4 Stories / 60 feet	5 Stories / 75 feet	1.5:1	up to 3.5:1	<ul style="list-style-type: none"> <li>Full-Service Grocery Store uses shall be exempt from the 2 story minimum height regulation.</li> <li>Projects that incorporate select Targeted Commercial Uses qualify for 5 story Bonus height.<sup>1</sup></li> <li>Projects that incorporate a Targeted Commercial Use(s), UL, PAOS and/or PP qualify for up to 3.5:1 Bonus FAR.</li> </ul>
			8 Stories / 120 feet		4:1	
G (TOD High)	2 Stories	7 Stories / 105 feet	N/A	1.5:1	2.25:1	<ul style="list-style-type: none"> <li>Professional Office and/or Research and Development Projects (where such uses shall comprise a minimum of 30 percent of the total square footage of the building) qualify for 2.25:1 Bonus FAR.</li> </ul>
			8 Stories / 120 feet		4:1	
H (TOD Regional Center)	2 Stories	12 Stories / 180 feet	13 Stories / 195 feet	3:1	up to 6:1	<ul style="list-style-type: none"> <li>Projects that incorporate a Targeted Commercial Use(s), UL, PAOS and/or PP qualify for up to 6:1 Bonus FAR and one additional story.</li> </ul>
			15 Stories / 225 feet		4:1	

<sup>1</sup> Targeted Commercial Uses see Section III-3 A.3 for bonus height  
<sup>2</sup> Targeted Commercial Use(s) (TCU), Unified Lot (UL), Publicly Accessible Open Space (PAOS) and/or a Public Plaza (PP); see Section III-3 B.2 for bonus FAR.

C. **Building Disposition.** In addition to any regulations set forth by the underlying zone and the LAMC, Projects with new construction or additions shall comply with the following disposition regulations:

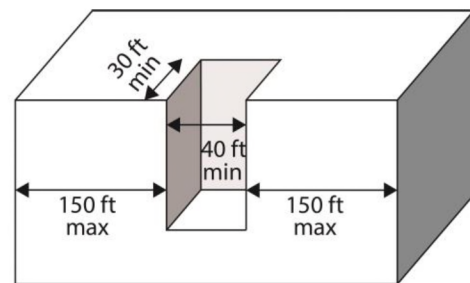
1. **Street Wall.** Any street facing façade of a Project where the cumulative total is greater than 300 feet in length shall comply with either subsection (a) or (b) below:

(a) Design the Project as separate buildings, with each not to exceed a maximum of 300 feet in length, separated by passageways that are open to the sky from sidewalk grade and are at least a minimum of 15 feet wide (separate buildings may be built upon the same subterranean parking structure); or



\*Figures are not to scale, illustrative only and not regulatory.

(b) Provide a continuous building base of 1 to 3 stories with upper floor volumes that do not exceed a maximum of 150 feet in length and separated by courtyards open to the sky that are a minimum of 40 feet wide and a minimum of 30 feet in depth, as measured from the street facing façade.



\*Figures are not to scale, illustrative only and not regulatory.

2. **Primary Frontage.**

(a) For all Projects, the Ground Floor shall be located along the Primary Lot Line for at least 75 percent of the length of the Primary Frontage, up to a minimum height of 12 feet as measured from the abutting sidewalk grade or right of way.

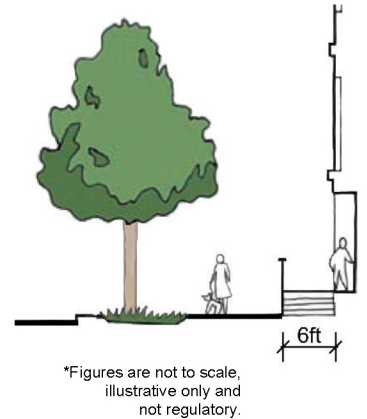
(b) The Ground Floor may be set back up to 20 feet along the Primary Frontage to the extent necessary to accommodate Pedestrian Amenities.

3. **Lot Coverage.** Projects shall provide a minimum lot coverage of 30 percent. Lot coverage shall be the cumulative total of the Building Footprint of all buildings on the lot including existing buildings to remain on the Project site and new buildings.

4. **Landscape Buffer.** A 5-foot landscape buffer, inclusive of all required setbacks, shall be provided between the Project site and any abutting lot zoned RD1.5 or more restrictive. Landscaping that is drought tolerant, evergreen, and capable of growing to a height of 10 feet shall be utilized, and a decorative masonry wall a minimum of six and a maximum of eight feet in height shall be constructed along the shared property line.

5. **Residential Setbacks**

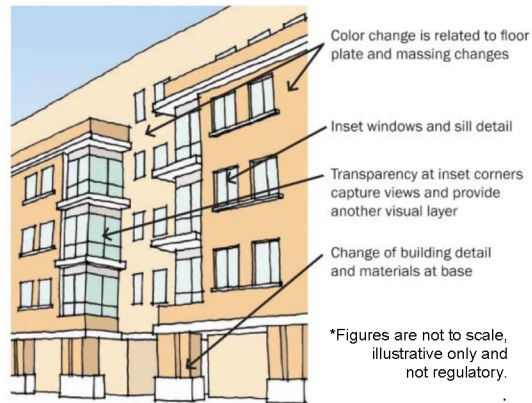
- (a) A Project that consists exclusively of residential dwelling units with no Active Floor Area, where permitted, shall be set back at least six feet and not more than ten feet from the property line. This setback area shall be improved with landscaping, Pedestrian Amenities or a combination thereof.
- (b) For Mixed-Use Projects, no setback requirements shall apply to any portion of a street facing building frontage used for residential uses.
- (c) Projects that involve the construction of new one and two family dwellings, including small lot subdivisions authorized by LAMC Section 12.22.C.27, shall have zero side-yard setbacks with abutting or shared common walls, as permitted by the Building Code.



**D. Building Design.** In addition to any regulations set forth by the underlying zone and the LAMC, Projects with new construction or additions shall comply with the following building design regulations:

1. **Glazing.** Clear transparent glazing (e.g., windows or doors), shall occupy a minimum of 50 percent of Primary Frontage of the Ground Floor. For all other building façades facing public streets, clear transparent glazing shall occupy a minimum of 15 percent inclusive of all floors except the Primary Frontage of the Ground Floor.
2. **Articulation.** All exterior building walls shall provide a break in the plane, or a change in material, at least every 20 feet in horizontal length and every 15 feet in vertical length, created by an articulation or architectural detail, such as:
  - (a) Ground Floor storefront bays;
  - (b) A change in plane of at least 18 inches;
  - (c) Windows that are recessed at least 2 inches, or that project such as bays;
  - (d) Building overhangs, such as canopies or eaves;
  - (e) Terraces, balconies, porches or cantilevered designs;
  - (f) Wood accents and wood trim for windows and doors;
  - (g) Varying roof forms and heights; and

- (h) Other Architectural Features or building materials that create a visual break (e.g. stucco reveals that are a minimum of 2 inches in depth).



3. **Projects Near Freeways.** For Projects that are within 100 feet of a freeway right-of-way, the following shall apply:
- (a) Balconies are not permitted on any portion of a building that is within 100 feet of a freeway right-of-way.
  - (b) Projects that abut a freeway right-of-way shall provide a minimum 5-foot landscaped setback from the freeway right-of-way property line. Landscaping that is drought tolerant, evergreen, and capable of growing to a height of 10 feet shall be utilized.
4. **Active Floor Area.** For all Projects, the Ground Floor of the Primary Frontage shall incorporate Active Floor Area or Pedestrian Amenities along up to 75 percent of the Primary Frontage to a depth of at least 25 feet excluding areas required to be used for vehicular access.
5. **Street-Oriented Entrance.**
- (a) Projects shall provide a Street-Oriented Entrance. Street-Oriented Entrances need not be parallel to the Primary Lot Line, provided that they are no more than 20 feet from the Primary Lot Line and augmented by entrance forecourts or other design features that establish a visual connection to the Primary Lot Line.
  - (b) For non-residential Projects, Street-Oriented Entrances shall be accessible during business hours and shall be no more than three feet above or below the sidewalk grade.

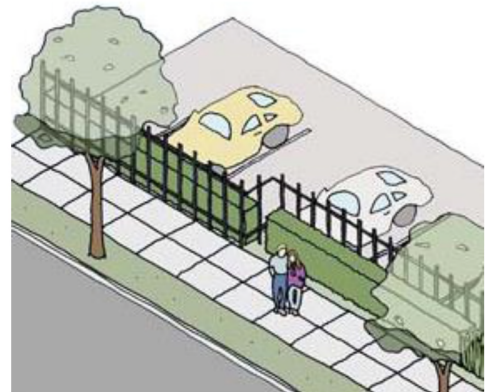
6. **Building Materials.**

- (a) Projects shall utilize two or more high-quality building materials and treatments on building exteriors such as brushed aluminum, brick, finished wood, or “Santa Barbara” smooth finish stucco.
- (b) The following materials and treatments are prohibited: Styrofoam plant-  
ons and rough texture stucco (Examples lace, heavy dash, tunnel dash, heavy sand float).
- (c) The Primary Frontage may be comprised of no more than 80 percent stucco.

E. **Parking Design.** In addition to any regulations set forth by the underlying zone and the LAMC, Projects with new construction or additions shall comply with the following parking design regulations:

- 1. **Parking Lot Location.** Surface parking areas shall not be located between the Property Lot Line and the Primary Frontage of a building. Surface parking shall be located at the rear or side of buildings. Parking can also be enclosed within a structure, or located entirely below grade. Below grade structures may occupy the entire footprint of a lot.

- 2. **Surface Parking Screening.** Where permitted, surface parking lots that abut public sidewalks shall provide a three-foot wide landscaped buffer, and a three and a half foot high decorative wall and/or hedge along the property line facing a street intended to screen headlights. The wall and/or hedge shall provide pedestrian entrances (separate from vehicular entrances) from the public sidewalk.



\*Figures are not to scale, illustrative only and not regulatory.

- 3. **Ground Floor Parking Level.** Wherever at-grade or above ground parking is to be provided within a building’s Ground Floor level fronting a public street (excluding alleys), the entire building shall be set back six feet from the adjacent public street and the setback shall be improved with diverse landscaping that is comprised of two or more plant types that, at maturity, screens the Ground Floor parking area up to a height of 10 feet. This requirement does not apply to that portion of the building where internal parking structures are buffered by habitable floor area on the Ground Floor such as retail space or a community room.

4. **Parking Structure Façades.** For stand-alone parking structures, provide an external skin or other material consistent with or complementary to the overall design of the building intended to improve the building's appearance over the basic concrete structure of ramps, walls and columns on all visible façades. Examples of appropriate skin material include heavy-gauge metal screen, pre-cast concrete panels, laminated glass, and photovoltaic panels.
  5. **Shade Trees.** Surface parking lots shall have at least one tree for every four uncovered parking spaces distributed throughout the parking lot to shade the parking area at maturity. A minimum of half of the trees planted shall be no less than a 24-inch box trees or a 15 gallon trees. Palm trees shall not be used to meet this requirement.
  6. **Pedestrian Walkway.** Within the surface-parking lot area, Projects shall provide at least one centrally located pedestrian walkway that runs the length of the parking lot from the sidewalk to the building entrance and is separated from the parking lot by landscaping and shade trees.
  7. **Vehicular Access.** Projects involving new buildings shall provide vehicular access from an alley or side street when available. Vehicular access from the Primary Frontage is prohibited unless the LADOT determines that no other reasonable alternative exists.
  8. **Curb Cuts.** Curb cuts shall be limited to the minimum number permitted as determined by LADOT and parking/loading entries into buildings shall be limited to the minimum number required and the minimum width permitted by the LAMC.
- F. **Signs.** In addition to any regulations set forth by the underlying zone and the LAMC, Projects shall comply with the following signage regulations:
1. **Prohibited Signs.** The following types of signs are prohibited: pole signs; illuminated architectural canopy signs; Feather Signs; digital displays; and Canister/Can/Cabinet Signs.
- G. **Equipment, Fencing and Utilities.** In addition to any regulations set forth by the underlying zone and the LAMC, Projects with new construction and additions shall comply with the following equipment and utility regulations:
1. **Security Devices.** Interior roll-down doors and security grilles that are at least 75 percent transparent (open), retractable, and designed to be fully screened from view during business hours are permitted. The following security devices are prohibited in all Projects:
    - (a) Permanently affixed exterior security grilles or bars.
    - (b) Exterior accordion (or scissor) gates.
    - (c) Exterior roll-down doors that are less than 75 percent transparent
    - (d) Exterior roll-down housing that is visible from the sidewalk.

2. **Mechanical Equipment.** Mechanical equipment shall be screened from public view using non-reflective materials or other material consistent with or complementary to the overall design of the building.
3. **Fencing.** Chain link fencing (with or without slats), corrugated metal fencing, and barbed/razor wire is prohibited along a Primary Frontage or where a parcel is either directly adjacent to or across an alley from a property in the RD1.5 or more restrictive zone or a property containing a Community Facility.
4. **Refuse Enclosures.** Areas where trash and recycling containers are stored outside shall be fully enclosed, including roofing, with solid masonry walls or other materials that have been determined to prevent the release of refuse odors.

**H. Auto-Related Use and New Automobile Sales Standards.** In addition to any regulations set forth by the underlying zone and the LAMC, Projects with Auto-Related Uses or New Franchise Automobile Sales Uses shall comply with the following regulations.

1. When a parcel is either directly adjacent to or across an alley from a residentially zoned property or a property containing a Community Facility, a solid masonry wall, at least six feet in height, for security and visual screening, shall be provided along the property line separating the parcel from the residentially zoned property or property containing a Community Facility.
2. No permit shall be issued until a covenant has been recorded on the subject property in a form and manner approved by the Department of City Planning, for the life of the use, demonstrating the following requirements shall apply:
  - (a) All actual repair or installation work shall be conducted within an enclosed building.
  - (b) All vehicles undergoing, or awaiting, repair or pick-up shall be parked on-site. Vehicles stored overnight shall be parked on-site. No on-street parking spaces shall be utilized for storage or parking of vehicles. Storage of or parking of vehicles for 30 or more days is prohibited.
  - (c) Equipment or parts removed from vehicles during the repair process shall be stored indoors or shall be deposited in an approved covered outdoor collection receptacle for appropriate off-site disposal.
  - (d) All loading and un-loading of vehicles shall be done on-site.

#### **Section III-4. PARKING REGULATIONS**

**A. Required Parking Spaces.** The required number of parking spaces for Projects with new construction shall be set forth in the applicable provisions of the LAMC except as provided in Table III-4, and as set forth below.

1. **Guest Parking.** Residential guest parking spaces may be provided through shared use of required commercial parking spaces in Mixed-Use Projects.

2. **Eligible Historic Resources.** That portion of a Project involving the Restoration or Rehabilitation of an Eligible Historic Resource shall be exempt from all off-street parking requirements so long as the existing number of parking spaces are retained.
  3. **Parking Incentives.** CPIO Affordable Housing Projects and certain identified commercial uses may reduce the required parking as set forth in Table III-4.
- B. Change of Use.** No additional parking shall be required for a change of use in an existing building from a non-residential use to a non-residential use permitted in the C1.5 zone.

**TABLE III-4:  
PARKING REGULATIONS**

Subareas: E (TOD Low); F (TOD Medium); G (TOD High); and H (TOD Regional)	
Parking Standards	Subarea
Projects that establish a Targeted Commercial Use other than a sit-down restaurant, may reduce the required parking for the Targeted Commercial Use by 25%.	E
CPIO Affordable Housing Projects may choose from the following 3 options: Options 1 and 2 – the same two options as set forth in LAMC Subsection 12.22 A.25(d). Option 3 – 25% less parking for the entire Project.	E
CPIO Affordable Housing Projects may choose from the following 3 options: Options 1 and 2 – the same two options as set forth in LAMC Subsection 12.22 A.25(d). Option 3 – 50% less parking for the entire project.	F, G, H
Projects that establish a Targeted Commercial Use, other than a sit-down restaurant, may reduce the required parking for the Targeted Commercial Use by 50%.	F, G, H
In new buildings, Sit-Down Restaurants of any size may provide a minimum of 1 parking space per 500 square feet of floor area.	E, F, G, H
Projects that establish a hotel, Professional Office Use, or Research and Development Use may reduce the required parking for that use by 25%.	G, H

# CHAPTER IV- INDUSTRIAL SUBAREAS

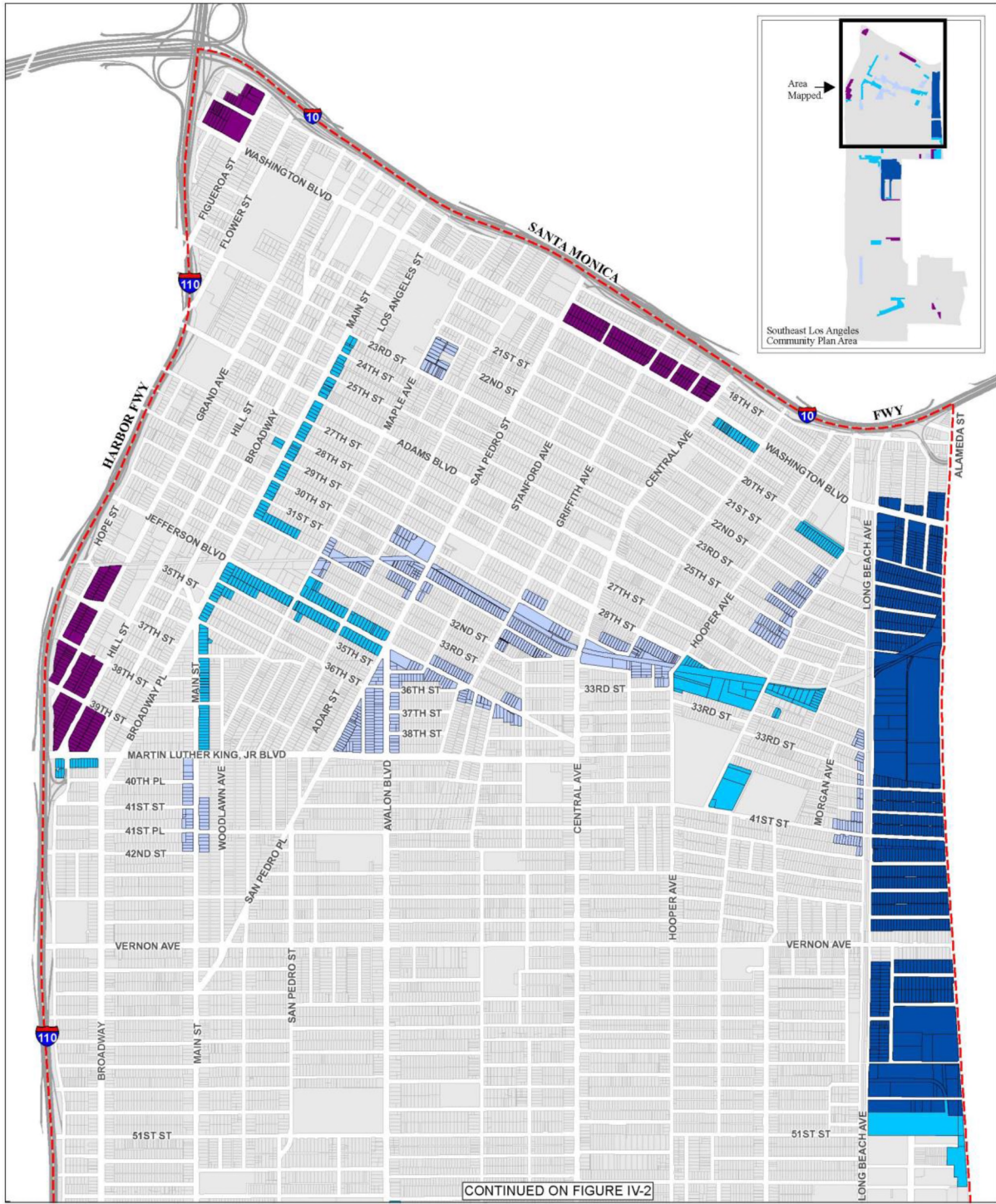
## INDUSTRIAL SUBAREAS

- I – Hybrid Limited
- J – Hybrid
- K – Compatible Industrial
- L – Industrial Innovation

## OVERVIEW

Industrial Subareas I, J, K, and L seek to preserve and revitalize industrial land throughout Southeast Los Angeles as described in Chapter 1, Section I-3 and consistent with the purposes set forth in Chapter 1, Section I-2.

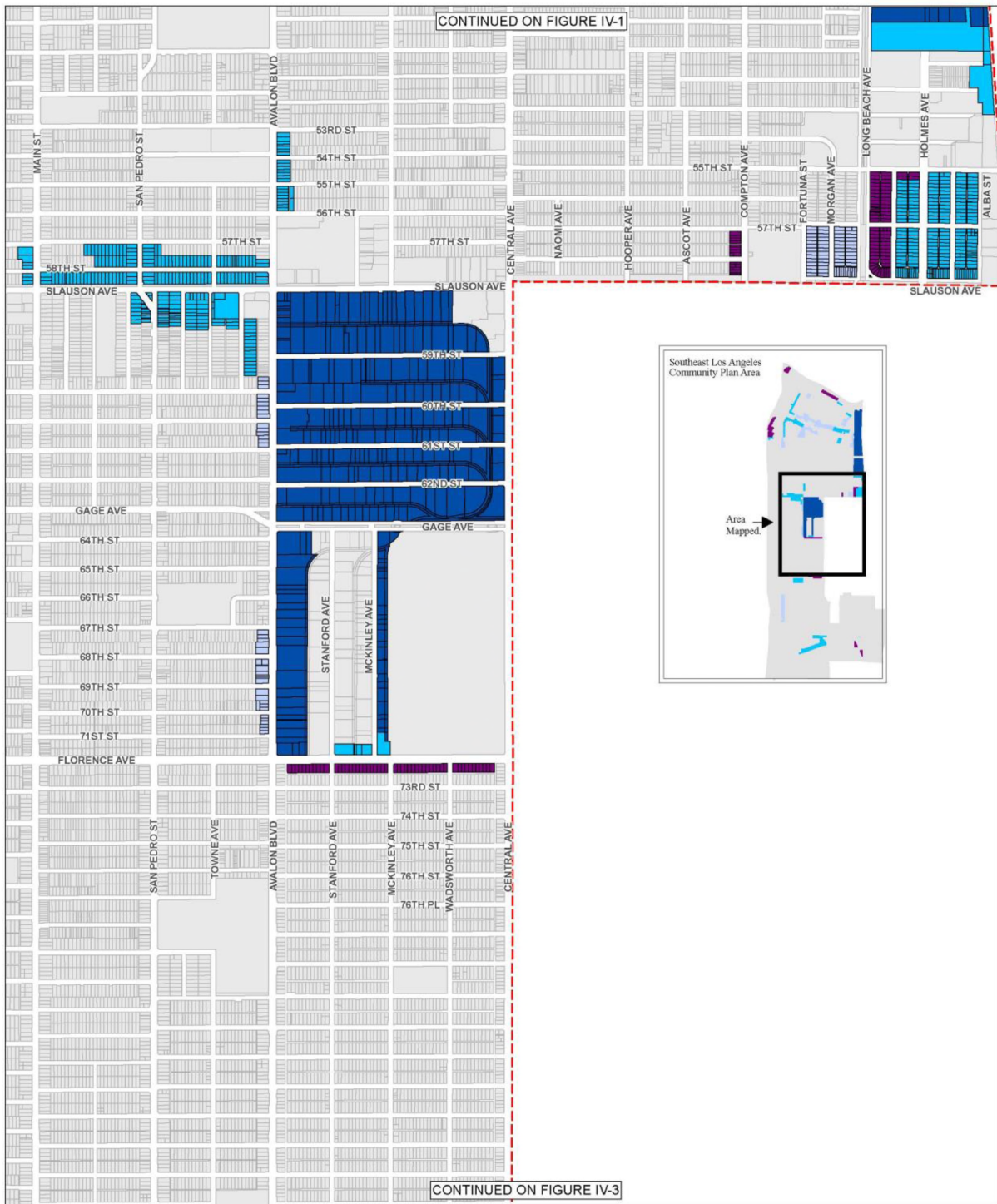
The intent of these supplemental development regulations in this Chapter is to upgrade industrial development and design standards in order to: encourage industry as a better neighbor to residences and other surrounding uses; protect industrial investment against incompatible residential, retail, and commercial uses; prevent future industrial blight; and improve the aesthetic character and quality of building facades and the edges of industrial areas as seen from public views. By employing design sensitivity, these CPIO subareas strive to improve the aesthetics of industrial buildings and quality of life for neighborhoods next to industrial uses. Projects within an Industrial Subarea (See Figures IV-1, IV-2, and IV-3) shall comply with the applicable supplemental development regulations in this Chapter.



**FIGURE IV-1. INDUSTRIAL SUBAREAS**

- Subarea I - Hybrid Limited
- Subarea J - Hybrid
- Subarea K - Compatible Industrial
- Subarea L - Industrial Innovation
- Southeast Los Angeles CPA

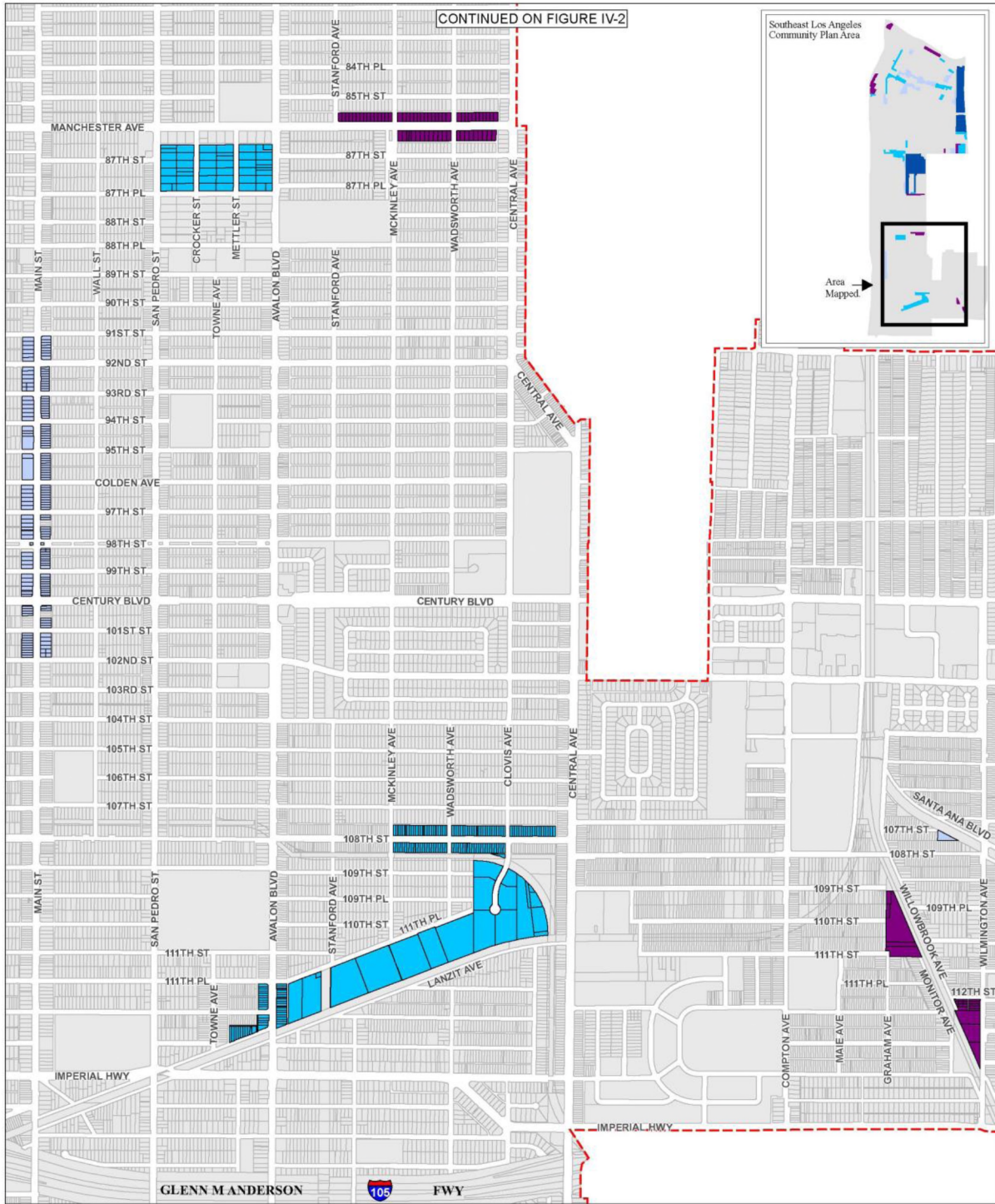




**FIGURE IV-2. INDUSTRIAL SUBAREAS**

- Subarea I - Hybrid Limited
- Subarea J - Hybrid
- Subarea K - Compatible Industrial
- Subarea L - Industrial Innovation
- Southeast Los Angeles CPA





## Section IV-1. LAND USE REGULATIONS

A. **Use Regulations.** Any new use or change of use shall be subject to and limited by the use restrictions set forth in Tables IV-1 and IV-2, below.

1. **Allowed Uses.**

- (a) In Subareas I, J or K, any new use or any change of use shall be limited only to the uses listed in Table IV-1, and as may be further regulated by Table IV-2.
- (b) In Subarea L, all uses allowed by the underlying zone shall be permitted except as set forth in Table IV-2.

B. **Existing Uses.** Legal non-conforming uses, including uses made non-conforming by this CPIO, shall comply with LAMC Section 12.23, except as follows:

- 1. **Residential Uses - Maintenance/Expansion.** An existing residential use in Subareas K or L may be repaired, maintained and/or expanded to a maximum of 20% of the building's legally permitted gross floor area but may not create an additional dwelling unit.

**TABLE IV-1: ALLOWED USES IN INDUSTRIAL SUBAREAS I, J, K**

Subareas: I: Hybrid Limited, J: Hybrid, K: Compatible Industrial			
Use <sup>1</sup>	Regulations <sup>2</sup>	Applicable Subarea	Exemptions/ Clarifications/ Regulations
Commercial Uses	Allowed.	I, J, K	Commercial Uses subject to any additional limitations by the underlying zone.
Community Facilities	Allowed.	I, J, K	
Light Manufacturing and Assembly	Allowed.	I, J, K	
Media Production	Allowed.	I, J, K	
Multipurpose Cultural Facilities	Allowed.	I, J, K	
Professional Office Uses	Allowed.	I, J, K	
Research and Development	Allowed.	I, J, K	

Subareas: I: Hybrid Limited, J: Hybrid, K: Compatible Industrial

Use <sup>1</sup>	Regulations <sup>2</sup>	Applicable Subarea	Exemptions/ Clarifications/ Regulations
<b>Residential Uses</b>	Allowed, except as limited below.  In Subarea I, Residential Uses shall comply with the limitations set forth in Section IV-2 B.2.(b)	I, J	
	Prohibited.	K	
<b>Vocational School</b>	Allowed.	I, J, K	
<b>Warehouse/Storage Building</b>	Allowed	I, J, K	All storage shall be within an enclosed building.

<sup>1</sup> Uses are defined in Chapter 1 of this CPIO or LAMC Section 12.03.

### TABLE IV-2: USE REGULATIONS

Subareas: I: Hybrid Limited, J: Hybrid, K: Compatible Industrial, L: Industrial Innovation

Use <sup>1</sup>	Regulation	Applicable Subarea	Exemptions/ Clarifications
<b>Alcohol Sales, Off-Site</b>	Not more than one establishment is permitted within a ½ mile (2,640 linear foot) radius of another Off-Site Alcohol Sales use. <sup>3</sup>	I, J, K, L	<ul style="list-style-type: none"> <li>• Full-Service Grocery Stores and Drug Stores are exempt.</li> <li>• Full-Service Grocery Stores that sell alcohol shall still be included in the ½ mile radius calculation when other new Off-Site Alcohol Sales requests are made in ½ mile proximity.</li> <li>• This term is also expressed as Off-Site Alcohol Sales.</li> </ul>

Subareas: I: Hybrid Limited, J: Hybrid, K: Compatible Industrial, L: Industrial Innovation

Use <sup>1</sup>	Regulation	Applicable Subarea	Exemptions/ Clarifications
<b>Auto-Related Use</b>	Not more than one establishment is permitted within a ½ mile (2,640 linear foot) radius of another Auto-Related Use. <sup>3</sup>	I, J, K	<ul style="list-style-type: none"> <li>Expansion, re-modeling, replacement of existing Auto-Related Uses, or inclusion of other accessory uses shall be allowed provided that such changes comply with the development standards of this CPIO and are allowed by the underlying zone.</li> <li>Multiple Auto-Related Uses or accessory Auto-Related Uses are allowed when combined within the same lot or parcel of an existing Auto-Related Use.</li> </ul>
<b>Freestanding Restaurant with Drive-Through</b>	Not more than one establishment is permitted within a ½ mile (2,640 linear foot) radius of another Freestanding Restaurant with Drive-Through use. <sup>3</sup>	I, J, K, L	<ul style="list-style-type: none"> <li>Expansion, re-modeling or replacement of existing establishments shall be permitted provided that such change complies with the development standards of this CPIO.</li> </ul>
<b>Gun Shop</b>	Not more than one establishment is permitted within a ½ mile (2,640 linear foot) radius of another Gun Shop use. <sup>3</sup>	I, J, K, L	
<b>Pawn Shop</b>	Not more than one establishment is permitted within a ½ mile (2,640 linear foot) radius of another Pawn Shop use. <sup>3</sup>	I, J, K, L	
<b>Noxious Uses</b>	These uses are prohibited within 2,500 feet of any Sensitive Land Uses.	L	
<b>Office Uses</b>	Allowed.	L	<ul style="list-style-type: none"> <li>Includes Creative Office Uses.</li> </ul>
<b>Recycling Collection</b>	Prohibited.	I, J, K	

Subareas: I: Hybrid Limited, J: Hybrid, K: Compatible Industrial, L: Industrial Innovation

Use <sup>1</sup>	Regulation	Applicable Subarea	Exemptions/ Clarifications
<b>Public Self Storage</b>	Limited. Not more than one establishment is permitted within a ½ mile (2,640 linear foot) radius of another Public Self Storage use. <sup>3</sup>	I, J, K, L	
<b>Restaurants</b>	Prohibited, except as exempted.	L	<ul style="list-style-type: none"> <li>• Properties fronting on Avalon, Central, Florence, Main, or Washington are exempt.</li> <li>• Cafes/restaurants constructed as an accessory use to the primary use are exempt.</li> </ul>
<b>Retail Sales (including Major Retailers)</b>	Prohibited, except as exempted.	L	<ul style="list-style-type: none"> <li>• Properties fronting on Avalon, Central, Florence, Main, or Washington are exempt.</li> </ul>
<b>Smoke/Vapor Shops</b>	Not more than one establishment is permitted within a ½ mile (2,640 linear foot) radius of another Smoke/Vapor Shop use. <sup>4</sup>	I, J, K, L	
<b>Residential Uses</b>	Limited.	I	<ul style="list-style-type: none"> <li>• Projects involving construction of a new building shall limit any residential floor area (excluding live/work units) to a maximum of 30% of the total floor area of the building.</li> </ul>
	Prohibited.	K, L	

<sup>1</sup> Uses are defined in Chapter 1 of this CPIO or LAMC Section 12.03.

<sup>2</sup> Permitted if applicable distance requirements are met.

<sup>3</sup> Distance shall be measured from the center point of the front lot line of the subject parcel to the nearest property line of any parcel containing the same use.

## Section IV-2. DEVELOPMENT STANDARDS

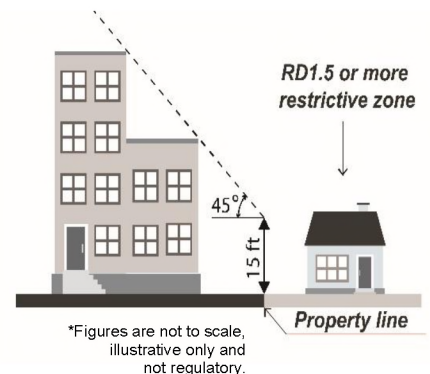
All Projects in Industrial Subareas are subject to the following development standards:

**A. Building Height.** In addition to the height standards set forth by the underlying zone and the LAMC, Projects with new construction or additions shall comply with the following height regulations:

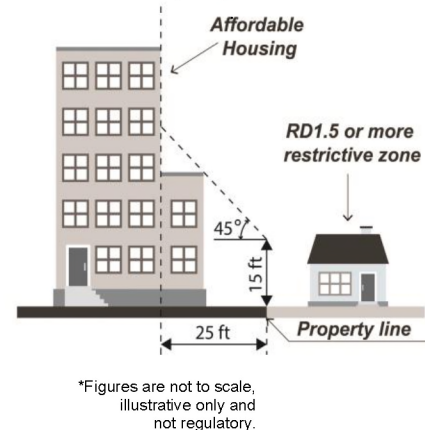
1. **Overall Height.** In Subareas I and J, all Projects in Height District 2D shall be limited to a maximum height of 3 stories except as follows:
  - (a) Live/work Projects shall not exceed a maximum height of 6 stories.
  - (b) TOC Projects or Density Bonus Projects shall have a Base height of 5 stories.
2. **Ground Floor.** For Projects involving the construction of a new building or additions, the following height restrictions apply:
  - (a) The Ground Floor shall have a minimum height of 14 feet, measured from the finished floor to the underside of the structural floor or roof above.
  - (b) For Projects with an Active Floor Area, the Ground Floor shall have a minimum height of 11 feet, measured from the finished floor to the finished ceiling.

3. **Transition to Residential.** The following height restrictions apply:

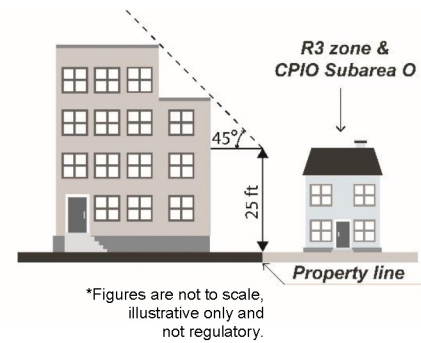
(a) The building height shall be stepped-back within a 45 degree angle as measured 15 feet above grade at the



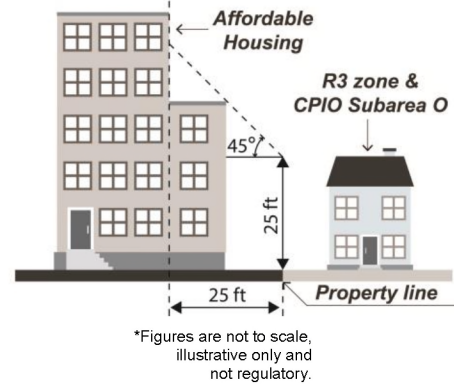
(b) For Density Bonus Projects or TOC Projects, the required height transition applies only to the first 25 feet of depth as measured from the property line of the lot in the more restrictive zone.



- (c) When adjacent to or across an alley from an R3 property in Subarea O, the building height shall be stepped-back within a 45 degree angle as measured 25 feet above grade at the property line of the lot in the R3 zone.



- (d) For Density Bonus Projects or TOC Projects, when on a property that is adjacent to or across an alley from an R3 property in Subarea O, the required height transition applies only to the first 25 feet of depth as measured from the property line of the lot in the more restrictive zone.



**B. Building Density and Floor Area Ratio (FAR).** In addition to any regulations set forth by the underlying zone and the LAMC, Projects shall comply with the following density and FAR regulations:

1. **Residential Density.** The maximum residential density shall be as set forth by the underlying zone.
2. **Floor Area Ratio (FAR).** The maximum building FAR shall be as set forth by the underlying zone, except as follows:
  - (a) In Subarea I, Mixed-Use Projects involving the construction of new buildings or additions to existing buildings shall limit residential floor area to 30 percent of the total building floor area, excluding live/work dwelling units. All 100 percent residential Projects shall be prohibited.
  - (b) In Subareas I and J, Projects involving the construction of new buildings or additions to existing buildings in Height District 2D, the maximum building FAR shall be 1.5:1 except as follows:
    - 1) Live/work Projects shall not exceed a maximum FAR of 3:1.
    - 2) Density Bonus Projects or TOC Projects shall have a Base FAR of 2.5:1.

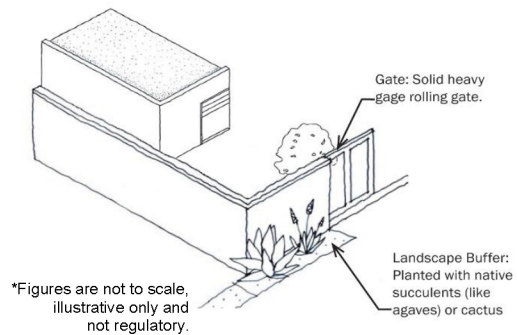
- C. Building Disposition.** In addition to any regulations set forth by the underlying zone and the LAMC, Projects with new construction or additions shall comply with the following disposition regulations:
1. **Residential-Adjacent Setbacks.** Industrial Projects shall provide a minimum 5-foot setback along any property line that is adjacent to a residentially zoned property.
    - (a) The residential-adjacent setback shall not be required when residential uses are located across a public street or alley from the Project site.
    - (b) A landscape buffer shall be provided within the residential-adjacent setback. The landscape buffer shall include a diversity of plant species, at least one of which is a hedge that grows to a minimum 10-foot height at maturity and is planted in at least 3-foot intervals.
  2. **Siting and Orientation.** In Subareas I, J and K, exterior mechanical equipment, loading areas and service bays shall be sited so that they are a minimum of 15 feet from abutting residentially-zoned properties in order to reduce noise, vibration, odor and glare to residential areas.
- D. Building Design.** For Projects with new construction in Subareas I, J, and K and for Projects with new construction in Subarea L that front on Avalon Boulevard, Central Avenue, Florence Avenue, Gage Avenue, Slauson Avenue, or Washington Boulevard, the following shall apply:
1. **Glazing.** The Ground Floor of the Primary Frontage shall provide clear transparent glass (e.g., storefront windows and doors) on at least 20 percent of a building's street-level façade as measured 10 feet from sidewalk grade.
  2. **Articulation.** The street facing building façade of a Project shall feature breaks that occur, at minimum, every 30 feet in horizontal distance, by utilizing a relief, graphic pattern or change in material, color or texture that provides scale and visual interest such as:
    - (a) A change in plane of at least 18 inches;
    - (b) Windows that are recessed at least 2 inches, or that project such as bays;
    - (c) Building overhangs, such as canopies or eaves;
    - (d) Terraces, balconies, proches or cantilevered designs;
    - (e) Wood accents and wood trim for windows and doors;
    - (f) Varying roof forms and heights; and
    - (g) Other Architectural Features or building materials that create a visual break, such as stucco reveals that are a minimum of 2 inches in depth.

### 3. Street-Oriented Entrance

- (a) Projects shall provide a Street-Oriented Entrance. Street-Oriented Entrances need not be parallel to the Primary Lot Line, provided that they are augmented by entrance forecourts or other design features that establish a visual connection to the Primary Lot Line.
- (b) For non-residential Projects, all Street-Oriented Entrances shall be accessible during business hours. Such entrances shall be no more than three feet above or below sidewalk grade.

### E. Parking

**Surface Parking Screening.** Where permitted, surface parking that abuts a public sidewalk shall provide a visual screen consisting of a three-foot wide landscaped buffer, and a three and a half foot high decorative wall, hedge or a combination thereof along the property line facing the street intended to screen headlights. The wall and/or hedge shall provide pedestrian entrances (separate from vehicular entrances) from the public sidewalk.



**F. Signs.** In addition to any regulations set forth by the underlying zone and the LAMC, Projects shall comply with the following signage regulations:

- 1. **Prohibited Signs.** The following types of signs are prohibited: pole signs; illuminated architectural canopy signs; Feather Signs; digital displays; and Canister/Can/Cabinet Sign.
- 2. **Required Signs.** An applicant shall provide a tenant identification sign for any non-residential uses.

**G. Equipment, Fencing and Walls, and Utilities.** In addition to any regulations set forth by the underlying zone and the LAMC, Projects with new construction and additions shall comply with the following equipment and utility regulations:

- 1. **Security Devices.** For buildings fronting on Avalon Boulevard, Central Avenue, Florence Avenue, Gage Avenue, Jefferson Boulevard, Main Street, Slauson Avenue, and Washington Boulevard, the following regulations shall apply:
  - (a) **Permitted.** Interior roll-down doors and security grilles must be at least 75 percent transparent (open), retractable, and designed to not be visible from the public right-of-way during business hours.

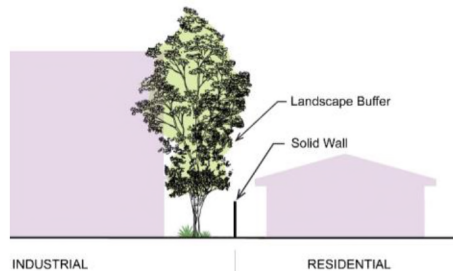
- (b) **Prohibited.** The following security devices are prohibited on all Primary Frontages:
  - (i) Permanently affixed exterior security grilles or bars.
  - (ii) Exterior accordion (or scissor) gates.
  - (iii) Exterior roll-down doors that are less than 75 percent transparent
  - (iv) Exterior roll-down doors that have exterior housing that is visible from the sidewalk.

2. **Mechanical Equipment.** For buildings fronting on Avalon Boulevard, Central Avenue, Florence Avenue, Gage Avenue, Jefferson Boulevard, Main Street, Slauson Avenue, and Washington Boulevard, mechanical equipment shall be screened from public view using non-reflective materials or other material consistent with or complementary to the overall design of the building.

3. **Fencing and Walls.** In addition to any regulations set forth by the underlying zone and the LAMC, Projects with new construction and additions shall comply with the following fencing and wall regulations:

- (a) For non-residential Projects, a solid wall with a minimum height of six feet shall be provided along any property line that is shared with a residential use, a residentially zoned lot, or any lot developed with a Community Facility. The wall shall be concrete masonry unit, brick, or other opaque, sturdy material. Wood fencing is prohibited.
- (b) Chain link fencing (with or without slats), corrugated metal and barbed/razor wire is prohibited.
- (c) Where a wall or fence is located adjacent to a public street or sidewalk (not including alleys), a minimum 3-foot landscaped setback shall be provided, with landscaping provided between the public street and the wall. Landscaping shall be drought-tolerant.

4. **Refuse Enclosures.** Areas where trash and recycling containers are stored outside shall be fully enclosed, including roofing, with solid masonry walls or other materials that have been determined to prevent the release of refuse odors.



\*Figures are not to scale, illustrative only and not regulatory.

H. **Lighting.** Provide outdoor lighting for all parking areas and pedestrian walkways for

security purposes but avoid spillover impacts onto adjacent properties. Glare shields shall be provided where necessary to avoid unwanted light flooding onto residential lots.

- I. **Open Storage and Open Air Work Standards.** For Projects that include storage and open air work areas, including pallet yards and storage yards, shall comply with the following:
- (a) **Subareas I, J, and K.** In Subareas I, J and K, when the site abuts a residentially-zoned property, all work and storage activities shall be performed wholly within an enclosed building.
  - (b) **Subarea L.** In Subarea L, open air storage and open work areas shall not be located within 15 feet of abutting residentially-zoned properties or existing school uses.
  - (c) **Fencing.** Solid perimeter fencing for outdoor storage, including storage yards and pallet yards, shall be provided consistent with materials described in Subsection G.3.(a) above, and shall be 12 feet high at side and rear only when abutting a residentially-zoned property.
  - (d) **Outdoor Storage.** Outdoor storage of materials, where allowed, shall not exceed the height of the exterior fence.

# CHAPTER V - RESIDENTIAL SUBAREAS

## **SUBAREA TYPES**

- M – Legacy Single-Family Residential
- N – Multi-Family Residential
- O – Character Residential

## **OVERVIEW**

The Residential Subarea Types M, N and O encourage well-designed projects that are compatible with the surrounding neighborhood scale and character as described in Chapter 1, Section I-3 and consistent with the purposes set forth in Chapter 1, Section I-2.

The intent of these supplemental development regulations in this Chapter IV is to strengthen residential neighborhood stability and guide new infill residential development to be consistent with prevailing neighborhood character. For all Residential Subarea types, Projects must meet basic design standards for front façades, front yards, roof forms, and building materials. Projects within a Residential Subarea (See Figures V-1, and V-2) shall comply with the applicable supplemental development regulations in this Chapter.



CONTINUED ON FIGURE V-2

**FIGURE V-1. RESIDENTIAL SUBAREAS**

- Subarea M - Legacy Single-Family
- Subarea N - Multi-Family
- Southeast Los Angeles CPA





**FIGURE V-2. RESIDENTIAL SUBAREAS**

- Subarea M - Legacy Single-Family
- Subarea N - Multi-Family
- Southeast Los Angeles CPA



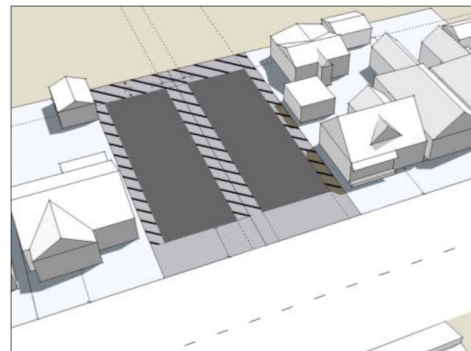
## Section V-1. LAND USE REGULATIONS

No additional land use regulations apply.

## Section V-2. DEVELOPMENT STANDARDS

Projects in the Residential Subareas are subject to the following development standards.

- A. Building Height.** In addition to the height standards established by the underlying zone and height district, Projects with new construction or additions shall comply with the following building step-back requirements:
- 1. Subarea M (Legacy Single-Family Residential).** Any story above the first story shall be stepped back a minimum of 10 feet from the first floor Primary Frontage facade or 30 feet from the Primary Lot Line, whichever is less restrictive.
  - 2. Subarea N (Multi-Family Residential).** No additional building step-back regulations apply.
  - 3. Subarea O (Character Residential).** Except for properties zoned R1R3 (Single Family - Rear Mass Variation Zone), the portion of a building above thirty feet shall be stepped back a minimum of 10 feet from the Primary Frontage façade.
- B. Building Disposition.** In addition to any regulations set forth by the underlying zone and the LAMC, Projects with new construction or additions shall comply with the following disposition regulations:
- 1. Bulk and Massing.**
    - (a) Subarea M (Legacy Single-Family Residential) and Subarea N (Multi-Family Residential).** No additional bulk and massing regulations apply.
    - (b) Subarea O (Character Residential)**
      - 1) For Projects on a Unified Lot, all buildings shall be designed to maintain the side and rear yard setback dimensions associated with the original individual lots set forth in B.2 (b)(1) below. A Project may not rely on the status of the lots being Unified Lots to waive or modify setback, yard area, or any other development standards related to bulk and massing. (See figure for illustrative example of this regulation.)**



\*Figures are not to scale,  
illustrative only and  
not regulatory.

- 2) Except for properties zoned R1R3, the total cumulative length of any side elevation above the first floor shall not extend more than 60 percent of the lot depth or 80 feet, whichever is less.

## 2. **Setbacks**

(a) **Subarea M (Legacy Single-Family Residential) and Subarea N (Multi-Family Residential).** No additional setback regulations apply.

(b) **Subarea O (Character Residential)**

(i) **Front.** The Primary Frontage shall be located no closer to the street than the Primary Frontage of the adjacent residential building closest to the street, and shall be located no further from the street than the Primary Frontage of the adjacent residential building farthest from the street.

(ii) **Side and Rear.** The side and rear setback dimensions shall be as set forth in the underlying zone, except as follows:

(1) New construction, including additions to existing buildings, on Unified Lots shall not encroach into side and rear setback areas associated with the original individual lots in accordance with B.1 (b)(1) above.

(2) The side and rear yard setback requirements shall not apply to accessory buildings (including but not limited to, garages, recreation rooms) provided the following requirements are met:

(iii) The accessory building's footprint does not exceed 10 percent of the overall square footage of the lot, the height does not exceed 15 feet, and the building is single story.

(iv) The accessory building shall be detached from the main house and set back a minimum of 10 feet, as measured from the rear most façade of the main house.

(v) In addition to the allowable yard projections in LAMC Section 12.22.C.20, loggias (covered walkways), gazebo structures and pools may encroach into the rear and side yard setback areas that are internal to Unified Lots.

(vi) Where the yard setback dimensions in this Chapter V are more restrictive than those set forth in the underlying zone, including LAMC Sections 12.22.C.27 (Small Lot Subdivisions) and 12.08 (R1R3 Variation Zone), the more restrictive setbacks shall prevail.

3. **Parking Areas, Garages and Carports.** Projects with onsite parking shall conform to the following standards:

- (a) **Subarea M (Legacy Single-Family Residential)**
  - (i) No parking areas shall be allowed between the Primary Frontage and the Primary Lot Line, except required driveways.
  - (ii) Detached or attached garages, parking areas, and carports associated with the construction of a new building shall be located behind any main building(s).
  - (iii) Projects that involve the construction of a new building(s) shall provide one additional on-site parking space for every bedroom over 3 bedrooms per dwelling unit.
  - (iv) Driveway widths shall be the minimum allowed by the LAMC and curb cuts shall be the minimum allowed by LADOT.
  
- (b) **Subarea N (Multi-Family Residential)**
  - (i) No parking areas shall be allowed between the Primary Frontage and the Primary Lot Line, except for required driveways.
  - (ii) Detached garages and carports associated with the construction of a new building shall be located behind any main building(s).
  - (iii) Attached parking areas shall be located either underground (subterranean or semi-subterranean), or behind any main building(s).
  - (iv) Any semi-subterranean parking areas (i.e. parking podiums) shall include exterior façades that are integrated into the overall architecture of the building, and that are accompanied by a minimum three-foot landscape buffer that is landscaped with plants that, at maturity, adequately screen the parking area.
  - (v) Driveway widths shall be the minimum allowed by the LAMC and curb cuts shall be the minimum allowed by LADOT
  
- (c) **Subarea O (Character Residential)**
  - (i) No parking areas shall be allowed between the Primary Frontage and the Primary Lot Line, except for required driveways.
  - (ii) Detached garages and carports shall be located behind any buildings, except for single-family properties zoned R1R3, which shall comply with the detached garage regulations of LAMC Section 13.19.
  - (iii) Attached parking areas shall be located either underground (subterranean or semi-subterranean), or behind any buildings.

- (iv) Any semi-subterranean parking areas (i.e. parking podiums) shall include exterior façades that are integrated into the overall architecture of the building, and that are accompanied by a minimum three-foot landscape buffer that is landscaped with plants that, at maturity, adequately screen the parking area.
  - (v) Access driveways shall be taken from alleys or side-streets when present.
  - (vi) Driveway widths shall be the minimum allowed by LAMC 12.21.A.5.
4. **Front Yards.** Residential front yards shall not be paved or used for vehicular parking or storage. Pavement shall be used only for walkways and driveways. Residential front yards shall be landscaped with plant materials, decomposed granite, turf block or a combination thereof. Residential front yards shall be open and not obstruct the views of the home from the street.
  5. **Parkways.** Parkways, the area between the street and sidewalk, when present, shall be porous and landscaped and shall be covered by an impervious surface.
  6. **Courtyards.** In Subarea O, a frontage of more than 100 feet shall incorporate a courtyard facing the street, at ground level, and open to the sky, that is at least 20 feet wide and 15 feet deep. For example, the building could be arranged on the lot in a U or L shape, around a central courtyard that faces a public street and is open to the sky.
- C. **Building Design.** In addition to any regulations set forth by the underlying zone and the LAMC, Projects with new construction or additions shall comply with the following design regulations:
1. **Primary Frontage.** A primary building entrance shall be provided that is directly visible and accessible from the Primary Lot Line, or individual entrances from a centrally located or common-access courtyard accessible from the Primary Lot Line. The primary building entrance(s) shall be accentuated by a canopy, recess, unique building materials, or another Architectural Feature that denotes the entrance against the rest of the façade.
  2. **Roof Forms.** Projects that involve the construction of additions or new detached dwelling units shall utilize roof forms that are consistent with the existing roof forms of the main building. For example, if a property is developed with a structure that has a 4/12 pitch gabled roof, the addition or second dwelling unit shall utilize the same gable roof pitch.
  3. **Building Materials**
    - (a) **Subarea M (Legacy Single-Family).** Projects shall utilize uniform building materials across all exterior facades, unless this requirement would conflict with requirements associated with new construction associated with Eligible Historic Resources. For example, if a property is developed with a house with exterior wood siding, an addition or new

detached dwelling unit on the site shall utilize the same or substitute with materials that give the same appearance.

(b) **Subarea N (Multi-Family Residential) and Subarea O (Character Residential)**

- 1) Projects shall utilize at least two building materials across all exterior façades of the building (e.g., wood window sashes, smooth stucco, wood, brick).
- 2) Rough texture stucco (e.g., lace, heavy dash, tunnel dash, heavy sand float) is prohibited.

4. **Articulation**

- (a) **Subarea M (Legacy Single-Family).** No additional articulation regulations apply.
- (b) **Subarea N (Multi-Family Residential) and Subarea O (Character Residential).** All exterior building walls shall provide a break in the plane or a change in material at least every 20 feet in horizontal length and every 15 feet in vertical length. Fenestration that is recessed a minimum of two inches from the outside wall may be counted as a break in plane.

D. **Historic Resources.** Any Project that qualifies as an Eligible Historic Resource shall comply with Chapter 1, Section I-6.C.5 of this CPIO.

# APPENDIX A – ENVIRONMENTAL STANDARDS

## OVERVIEW

As described in Section 1-9 of the CPIO District, these Environmental Standards are included to implement the Mitigation & Monitoring Program included as part of the South Los Angeles and Southeast Los Angeles Community Plans update and reviewed in the South Los Angeles and Southeast Los Angeles Environmental Impact Report (Case No. ENV-2008-1780-EIR), certified by the City Council.

In addition to Projects in Subareas that are required to comply with these Environmental Standards, any other discretionary project in the boundaries of the Southeast Los Angeles Community Plan Area that seeks to rely on the Southeast Los Angeles EIR for its CEQA clearance (including through tiering, preparing an addendum, supplemental EIR or a statutory infill exemption), may incorporate or impose the following Environmental Standards on the project. Compliance may be achieved through covenant, conditions, plan notations, or other means determined reasonably effective by the Director of Planning or the decision-maker.

## AIR QUALITY

**AQ1** Projects (except for Residential Subareas M, N, and O) shall ensure all contractors include the best management practices provided in the bulleted list below in contract specifications:

- Restrict idling of construction equipment and on-road heavy duty trucks to a maximum of 5 minutes when not in use.
- Use diesel-fueled construction equipment to be retrofitted with after treatment products (e.g. engine catalysts) to the extent they are readily available and feasible.
- Use heavy duty diesel-fueled equipment that uses low NO<sub>x</sub> diesel fuel to the extent it is readily available and feasible.
- Use construction equipment that uses low polluting fuels (i.e. compressed natural gas, liquid petroleum gas, and unleaded gasoline) to the extent available and feasible.
- All on-road heavy-duty diesel trucks or equipment with a gross-vehicle weight rating (GVWR) of 19,500 pounds or greater shall comply with EPA 2007 on-road emission standards for PM and NO<sub>x</sub>:
  - PM – 0.01 g/bhp-hr
  - NO<sub>x</sub> – at least 1.2 g/bhp-hr
- Use zero-emission trucks and equipment where available, or cleanest available technology.
- Every effort should be made by the Contractor to utilize grid-based electric power at any construction site, where feasible.
- Where access to the power grid is not available, on-site generators are required to meet 0.01 g/bhp-hr standard for PM, or be equipped with Best Available Control Technology (BACT) for PM emissions reductions.
- Use building materials, paints, sealants, mechanical equipment, and other materials that yield low air pollutants and are nontoxic.
- Construction contractors shall use pre-painted construction materials, as feasible.
- Construction contractors shall provide temporary traffic controls such as a flag person, during all phases of construction to maintain smooth traffic flow.
- Prepare haul routes, when required by the LAMC, that conform to local requirements to minimize traversing through congested streets or near sensitive receptor areas.

- Maintain a buffer zone that is a minimum of 1,000 feet between truck traffic and sensitive receptors, where feasible.
- When required by LADOT, upgrade signal synchronization to improve traffic flow.
- Configure construction parking to minimize traffic interference.
- When required by LADOT, provide dedicated turn lanes for movement of construction trucks and equipment on- and off-site.
- Schedule construction activities that affect traffic flow on the arterial system to off-peak hours to the extent practicable.
- Traffic speeds on all unpaved roads shall be 15 mph or less.
- Construction contractors shall reroute construction trucks away from congested streets or sensitive receptor areas, as feasible.
- Construction contractors shall appoint a construction relations officer to act as a community liaison concerning on-site construction activity including resolution of issues related to PM<sub>10</sub> generation. The name and contact information of the construction relations officer shall be posted at a location on the project site that is accessible and visible from the public right-of-way.
- Identify Sensitive Uses within 500 feet of a project that involves ground-disturbing activities and notify sensitive uses before construction projects occur, including disclosure of the name and contact information for the construction relations officer acting as the community liaison.
- Implement the fugitive dust control measures as required in the South Coast Air Quality Management District's Rule 403 Fugitive Dust.
- Require installation of high efficiency filtration systems (MERV 13) for housing projects within 500 feet of freeways and oil drilling sites.

## **CULTURAL RESOURCES**

**CR1** Projects (excluding Residential Subareas M, N, and O) that involve construction-related soil disturbance shall require that if during construction activities any cultural materials are encountered, construction activities within a 50-meter radius shall be halted immediately and the project applicant shall notify the City. A qualified archeologist (as approved by the City) shall be retained by the project applicant and shall be allowed to conduct a more detailed inspection and examination of the exposed cultural materials. During this time, excavation and construction would not be allowed in the immediate vicinity of the find. However, those activities could continue in other areas of the project site. If the find were determined to be significant by the archeologist, the City and the archeologist would meet to determine the appropriate course of action. All cultural materials recovered from the site would be subject to scientific analysis, professional museum curation, and a report prepared according to current professional standards.

**CR2** Projects (excluding Residential Subareas M, N, and O) that involve construction-related soil disturbance shall require that during excavation and grading, if paleontological resources are uncovered, all work in that area shall be halted immediately and the project applicant shall notify the City. The project applicant shall retain a paleontologist to assess the nature, extent, and significance of any cultural materials that are encountered and to recommend appropriate methods to preserve any such resources. Said paleontologist will have the authority to put a hold on grading operations and mark, collect and evaluate any paleontological resources found on the site where it is discovered during construction. Said paleontologist shall be provided a reasonable amount of time to prepare and implement protection measures coordinating with the

City of Los Angeles Building and Safety Department. Any paleontological remains and/or reports and surveys shall be submitted to the Los Angeles County Natural History Museum.

**CR3** In the event that objects or artifacts that may be tribal cultural resources are encountered during the course of any ground disturbance activities (excavating, digging, trenching, plowing, drilling, tunneling, quarrying, grading, leveling, removing peat, clearing, driving posts, augering, backfilling, blasting, stripping topsoil or a similar activity), all such activities shall temporarily cease on the project site until the potential tribal cultural resources are properly assessed and addressed pursuant to the process set forth below:

- Upon a discovery of a potential tribal cultural resource, the Applicant shall immediately stop all ground disturbance activities and contact the following: (1) all California Native American tribes that have informed the City they are traditionally and culturally affiliated with the geographic area of the proposed project; (2) and the Department of City Planning, Office of Historic Resources.
- If the City determines, pursuant to Public Resources Code Section 21074 (a)(2), that the object or artifact appears to be tribal cultural resource, the City shall provide any effected tribe a reasonable period of time, not less than 14 days, to conduct a site visit and make recommendations to the Applicant and the City regarding the monitoring of future ground disturbance activities, as well as the treatment and disposition of any discovered tribal cultural resources.
- The Applicant shall implement the tribe's recommendations if a qualified archaeologist and by a culturally affiliated tribal monitor, both retained by the City and paid for by the Applicant, reasonably concludes that the tribe's recommendations are reasonable and feasible.
- The Applicant shall submit a tribal cultural resource monitoring plan to the City that includes all recommendations from the City and any effected tribes that have been reviewed and determined by the qualified archaeologist and by a culturally affiliated tribal monitor to be reasonable and feasible. The Applicant shall not be allowed to recommence ground disturbance activities until this plan is approved by the City.
- If the Applicant does not accept a particular recommendation determined to be reasonable and feasible by the qualified archaeologist or by a culturally affiliated tribal monitor, the Applicant may request mediation by a mediator agreed to by the Applicant and the City who has the requisite professional qualifications and experience to mediate such a dispute. The Applicant shall pay any costs associated with the mediation.
- The Applicant may recommence ground disturbance activities outside of a specified radius of the discovery site, so long as this radius has been reviewed by the qualified archaeologist and by a culturally affiliated tribal monitor and determined to be reasonable and appropriate.
- Copies of any subsequent prehistoric archaeological study, tribal cultural resources study or report, detailing the nature of any significant tribal cultural resources, remedial actions taken, and disposition of any significant tribal cultural resources shall be submitted to the South Central Coastal Information Center (SCCIC) at California State University, Fullerton.

## **HAZARDS AND HAZARDOUS MATERIALS**

**HM1** Projects that involve construction-related soil disturbance located on land that is currently or was historically zoned as industrial shall conduct a comprehensive search of databases of sites containing hazardous waste or hazardous materials, including on lists prepared pursuant to Government Code Section 65962.5. A report setting forth the results of this database search shall be provided to the City and shall be made publicly available (e.g. historical environmental reports prepared by Enviroscan, EDR or similar firms). If the report indicates the project site or property within one-quarter mile of the project site has the potential to be contaminated with hazardous waste or hazardous materials for any reason, a Phase I Environmental Site Assessment (ESA) shall be prepared.

The Phase 1 ESA shall identify any hazardous materials/wastes that could be present on the project site. The Phase 1 shall also include recommendations and measures for further site assessment to address any hazardous materials/wastes potentially present on the project site. The Phase 1 assessment shall be prepared by an Environmental Professional (as defined in Title 40 Code of Federal Regulations § 312.10 Definitions) to evaluate whether the site or the surrounding area is contaminated with hazardous substances from the potential past and current uses. The ESA shall be made publicly available. Depending on the results of the Phase 1 ESA, further investigation and remediation may be required in accordance with local, state, and federal regulations and policies and shall be clearly indicated in the ESA. If the Phase 1 ESA finds that there is no contamination on the site, a letter of No Further Action shall be provided to the City.

The City shall require that a Phase 2 Site Assessment be conducted as may be indicated by the site-specific Phase 1 Environmental Site Assessment. If a Phase 2 is found necessary, it shall be performed prior to project approval or made a condition on the project if that is found to be adequate for remediation by the Environmental Professional and the relevant federal, state, or local agency.

Should the Phase 2 Site Assessment indicate soil and/or groundwater contamination is present, a detailed Soil Management Plan (SMP) for the treatment of contaminated soils and materials shall be developed and implemented in accordance with applicable laws and regulations. The SMP shall be prepared prior to the Department of Building and Safety's issuance of a grading permit to review and address any impacted soil that may be encountered during excavation and grading. The SMP shall provide for the sampling, testing, and timely disposal of such soil and shall specify the testing parameters and sampling frequency. Any impacted soils shall be properly treated and disposed of in accordance with applicable SCAQMD, DTSC, and LARWQCB requirements. An Environmental Professional shall be on-site during excavation and grading of the project site to monitor environmental conditions pertaining to soil. Written confirmation by the Environmental Professional stating that required site remediation was completed consistent with the relevant federal, state or local requirements shall be provided to the City prior to issuance of certificates of occupancy.

## **NOISE AND VIBRATION**

**N1** Projects (except for Residential Subareas M, N, and O) shall ensure that all contractors include the following best management practices in contract specifications, where applicable:

- Construction haul truck and materials delivery traffic shall avoid residential areas whenever feasible. If no alternatives are available, truck traffic shall be routed on streets with the fewest residences.
- The construction contractor shall locate construction staging areas away from sensitive uses.
- When construction activities are located in close proximity to noise-sensitive land uses, noise barriers (e.g., temporary walls or piles of excavated material) shall be constructed between activities and noise sensitive uses.
- Impact pile drivers shall be avoided where possible in noise-sensitive areas. Drilled piles or the use of a sonic vibratory pile driver are quieter alternatives that shall be utilized where geological conditions permit their use. Noise shrouds shall be used when necessary to reduce noise of pile drilling/driving.
- Construction equipment shall be equipped with mufflers that comply with manufacturers' requirements.
- The construction contractor shall use on-site electrical sources to power equipment rather than diesel generators where feasible.
- Use electric or solar generators, when available.

**N2** Projects (except for Residential Subareas M, N, and O) shall comply with the following conditions:

- Industrial activity yards that include the operation of heavy equipment shall be shielded by sound barriers that block line-of-sight to sensitive receptors.
- Mechanical equipment (e.g., heating, ventilation and air conditioning (HVAC) Systems) shall be enclosed with sound buffering materials.
- Truck loading/unloading activity shall be prohibited between the hours of 10:00 p.m. and 7:00 a.m. when located within 200 feet of a residential land use.
- Parking structures located within 200 feet of any residential use shall be constructed with a solid wall abutting the residences and utilize textured surfaces on garage floors and ramps to minimize tire squeal.

**N3** Projects (except for Residential Subareas M, N, and O) that are adjacent to buildings listed or determined eligible for listing in the National Register of Historic Places or the California Register of Historical Resources, designated as a Historic-Cultural Monument by the City of Los Angeles, within a Historic Preservation Overlay Zone ("historic buildings"), or determined to be historically significant in SurveyLA or other historic resource survey meeting all of the requirements of Public Resources Code Section 5024.1(g), shall ensure all of the following requirements are met:

- Historic buildings adjacent to the project's construction zones are identified.
- A Vibration Control Plan is prepared and approved by the City.
- The Vibration Control Plan shall be completed by a qualified structural engineer.
- The Vibration Control Plan shall include a pre-construction survey letter establishing baseline conditions at potentially affected buildings. The survey letter shall provide a shoring design to protect the identified land uses from potential damage. The structural

engineer may recommend alternative procedures that produce lower vibration levels such as sonic pile driving or caisson drilling instead of impact pile driving.

At the conclusion of vibration causing activities, the qualified structural engineer shall issue a follow-up letter describing damage, if any, to impacted buildings. The letter shall include recommendations for any repair, as may be necessary, in conformance with the Secretary of the Interior Standards. Repairs shall be undertaken and completed in conformance with all applicable codes including the California Historical Building Code (Part 8 of Title 24).

**N4** Projects (except for Residential Subareas M, N, and O) shall ensure that all contractors include the following best management practices in contract specifications, where applicable:

- Impact pile drivers shall be avoided where possible in vibration-sensitive areas. Drilled piles or the use of a sonic vibratory pile driver are alternatives that shall be utilized where geological conditions permit their use.
- The construction activities shall involve rubber-tired equipment rather than metal-tracked equipment.
- The construction contractor shall manage construction phasing (scheduling demolition, earthmoving, and ground-impacting operations so as not to occur in the same time period), use low-impact construction technologies, and shall avoid the use of vibrating equipment where possible to avoid construction vibration impacts.