

## TRANSMITTAL

To: **THE COUNCIL**

Date: **07/27/22**

From: **THE MAYOR**

TRANSMITTED FOR YOUR CONSIDERATION. PLEASE SEE ATTACHED.

A handwritten signature in black ink that reads "Mary Hodge". The signature is written in a cursive, flowing style.

**ERIC GARCETTI**  
**Mayor**  
(Mary Hodge for)

# LOS ANGELES FIRE COMMISSION

BOARD OF  
FIRE COMMISSIONERS

JIMMIE WOODS-GRAY  
PRESIDENT

JIMMY H. HARA, M.D.  
VICE PRESIDENT

CORINNE TAPIA BABCOCK  
DELIA IBARRA  
REBECCA NINBURG

LETICIA GOMEZ  
COMMISSION EXECUTIVE ASSISTANT II



ERIC GARCETTI  
Mayor

SUE STENDEL  
INDEPENDENT ASSESSOR

EXECUTIVE OFFICE  
200 NORTH MAIN STREET, SUITE 1840  
LOS ANGELES, CA 90012

(213) 978-3838 PHONE  
(213) 978-3814 FAX

July 19, 2022

Honorable Members of the City Council  
City of Los Angeles  
City Hall, Room 395  
Attn: City Clerk

Honorable Eric Garcetti  
Mayor, City of Los Angeles  
Room 303, City Hall  
Attn: Legislative Coordinator

[BFC 22-065] – IN-KIND DONATION OF TWO COMMERCIAL-GRADE WASHERS AND DRYERS TO FIRE STATION 61

At its special meeting of July 19, 2022, the Board of Fire Commissioners approved the report and its recommendations. The report is hereby transmitted concurrently to the Mayor and City Council for consideration and approval.

Should you need additional information, please contact the Board of Fire Commissioners' office at 213-978-3838.

Sincerely,

Leticia Gómez  
Commission Executive Assistant II

Attachments

cc: Fire Chief Kristin Crowley (via email)  
Office of the City Administrative Officer (via email)

# LOS ANGELES FIRE DEPARTMENT



KRISTIN M. CROWLEY  
FIRE CHIEF

APPROVED: *7/20/2022*  
BOARD OF FIRE COMMISSIONERS  
BY: *[Signature]*  
COMMISSION EXECUTIVE ASSISTANT

July 8, 2022

BOARD OF FIRE COMMISSIONERS  
FILE NO. 22-065

TO: Board of Fire Commissioners

FROM: *[Signature]* Kristin M. Crowley, Fire Chief

SUBJECT: IN-KIND DONATION OF TWO COMMERCIAL-GRADE WASHERS AND DRYERS TO FIRE STATION 61

FINAL ACTION:	<input checked="" type="checkbox"/> Approved	<input type="checkbox"/> Approved w/Corrections	<input type="checkbox"/> Withdrawn
	<input type="checkbox"/> Denied	<input type="checkbox"/> Received & Filed	<input type="checkbox"/> Other

## SUMMARY

The First-In Foundation has graciously donated two commercial-grade washers and three commercial-grade dryers from Park La Brea and WASH to Fire Station 61. Currently, Fire Station 61 has two old household washers and three household-style dryers. Replacing these appliances with two new robust and reliable commercial washers and dryers would benefit the members in efficiently maintaining clean uniforms, workout clothing, dish towels and more. The donated items would improve the quality of life for members of Fire Station 61. The value of this donation is estimated at \$8,858.

## RECOMMENDATIONS

That the Board:

1. Receive this report for the In-Kind Donation by First-In Fire Foundation for the items listed above, valued at \$8,858. to the Los Angeles Fire Department.
2. Request the Commission Executive Assistant to transmit this report to the Mayor's Office in accordance with Executive Directive No. 3 and to City Council in accordance with the Los Angeles Administrative Code, Ordinance 15514, Article 12, Section 5.111.4, for consideration and approval.

## FISCAL IMPACT

There is no fiscal impact on the Department's budget from the acceptance of this donation. Donations provide the necessary items to meet the needs of the respective fire stations or administration sections. Replacement or repair of items meeting City specifications and Fire Department business needs may be borne by General Fund, subject to budgetary constraints.

**CONCLUSION**

The Los Angeles Fire Department benefits tremendously from gracious donations and support provided by the First-In Foundation. The LAFD acknowledges the Foundation for its generosity.

Board report was prepared by Acting Public Information Director Cheryl Getuiza, Community Liaison Office.

Attachment

**LOS ANGELES FIRE DEPARTMENT**



KRISTEN M. CROWLEY  
FIRE CHIEF

June 15, 2022

TO: Honorable Board of Fire Commissioners, THROUGH CHANNELS

FROM: Paul N. Pham, Battalion Chief  
Battalion 18, C Platoon

SUBJECT: IN-KIND DONATION FOR FIRE STATION 61

SUMMARY

Fire Station 61 Commanders are requesting permission to accept a donation of two commercial grade washers and three commercial grade dryers from Park La Brea and WASH through the First-In Fire Foundation.

RECOMMENDATION

It is respectfully recommended that the Board of Fire Commissioners approve the request to accept the donation of the commercial washers and dryers.

FINDINGS

Fire Station 61 does currently have two old household style washers and three household style dryers. Replacing these appliances with two new robust and reliable commercial washers and three commercial dryers would benefit the members of Fire Station 61. The appliances are identified as:

Washer - Speed Queen Quantum Gold Pro top load washers Model #SWNNY2SP116TW01 at a valued cost of \$2017 per washer.

Dryer - Speed Queen Quantum Gold Pro rear control single dryers Model #DGNRGS116TW01 at a value cost of \$1608 per dryer.

Total Donation Value - 2 X \$2017 + 3 X \$1608 = \$8,858

22-06-0124

COMPANY/STATION/UNIT COMMANDER	DATE	EMS BATTALION CAPTAIN	DATE	BATTALION COMMANDER	DATE	DIVISION COMMANDER <i>Paul N. Pham for</i>	DATE <i>6/17/22</i>
<i>Ramin Villanar</i>	<i>6/17/22</i>	<i>Adrian Z. Jarama</i>	<i>6/28/22</i>				

Park La Brea is a large and highly populated apartment community that sits on 160 acres in the Miracle Mile District of Los Angeles and whose fire district belongs to Fire Station 61. A small "city" housing up to 12,000 residents, the Park La Brea community frequently calls upon the members of Fire Station 61 to respond and mitigate their medical and fire related incidents. The Park La Brea management company has expressed sincere gratitude for Fire Station 61's consistent exceptional service and upon a station visit offered to replace 61's old washer and dryer appliances with rugged and commercial type appliances commonly used throughout the Park La Brea property and supplied by the WASH company. Tested to be reliable in Park La Brea, these donated appliances would improve the quality of life for the members of Fire Station 61.

As the donation would be a one for one replacement of existing house due paid for appliances, it has been verified that the donation of the washers and dryers will not incur any city costs or maintenance other than the cost to power the efficient appliances.

CONCLUSION

Having two reliable commercial grade washers and three dryers would greatly assist the members working at Fire Station 61 in efficiently maintaining clean uniforms, workout clothing, dish towels, etc. The members at Fire Station 61 are grateful for the opportunity to accept such a useful donation by Park La Brea and WASH through the First-In Fire Foundation. The Battalion 18 office supports Fire Station 61's request and respectfully requests the Board's approval.

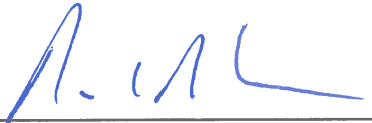

Paul N. Pham, Battalion Chief  
Battalion 18, C Platoon

Attachments

RECEIVED  
22 JUN 28 PM 3:21  
EMERGENCY OPERATIONS

**LOS ANGELES FIRE DEPARTMENT**

**KRISTEN M. CROWLEY**  
 FIRE CHIEF

June 11, 2022

**TO:** Honorable Board of Fire Commissioners, THROUGH CHANNELS  
**FROM:** Commanders, Fire Station 61, A, B and C Platoon  
 Battalion 18  
**SUBJECT:** IN-KIND DONATION FOR FIRE STATION 61

SUMMARY

Fire Station 61 Commanders are requesting permission to accept and utilize an appliance donation from Park La Brea and WASH through the First-In Fire Foundation. The donation consists of two washers and three dryers that are commercial grade.





RECOMMENDATION

It is respectfully recommended that the Board of Fire Commissioners approve the request to accept the donation of the commercial washers and dryers.

FINDINGS

Fire Station 61 currently have two household style washers and three household style dryers. Two commercial washers and three commercial dryers to replace the household style appliances were identified to meet the needs at Fire Station 61. The appliances identified as Speed Queen commercial grade washers and dryers are used in high capacity at Park La Brea and have proven to be robust. The model of washers to be donated are Speed Queen Quantum Gold Pro top load washers Model #SWNNY2SP116TW01 at a cost of \$2017 per washer. The dryers to be donated are Speed Queen Quantum Gold Pro rear control single dryers Model #DGNYRGS116TW01 at a cost of \$1608 per dryer. Both models' specification sheets are attached.

Fire Station 61 consists of a Task Force, Paramedic and BLS Rescue, and an EMS Captain. With an upwards of 15 members per day at the fire station, there is a need for

COMPANY/STATION/UNIT COMMANDER 	DATE	EMS BATTALION CAPTAIN	DATE	BATTALION COMMANDER 	DATE	DIVISION COMMANDER 	DATE
6/11/22				6/13/22		for 6/17/22	
BUREAU COMMANDER 	DATE	EMERGENCY OPERATIONS COMMANDER	DATE	ADMINISTRATIVE OPERATIONS COMMANDER DATE			
6/17/22							

reliable commercial grade washers and dryers to keep up with the demand of a large capacity station. The current station washers and dryers are old, frequently breaking down, and need to be replaced.

As a result of the current fire department staffing crisis, members are working more consecutive shifts and working from other fire stations which has increased the need for the use of the cleaning appliances. Additionally, with the increase in call load, having multiple units would assist in the ability for multiple members to be able to wash their clothes at the same time when they are ready to do so instead of waiting.

### CONCLUSION

Having two reliable commercial grade washers and three dryers would greatly assist the members in maintaining clean uniforms, workout clothing and dish towels. The members at Fire Station 61 are grateful for the opportunity to accept such a useful donation by Park La Brea and WASH through the First-In Fire Foundation, and the approval to accept it would be greatly appreciated.



Douglas Noonan, Captain II  
Fire Station 61, A Platoon



Timothy Ketailey, Captain I  
Fire Station 61, A Platoon



Richard Martinez, Captain I  
Fire Station 61, B Platoon



Jason Jamal, Captain I  
Fire Station 61, C Platoon

**Attachments**



# Top Load Washer

## Quantum® Gold Pro

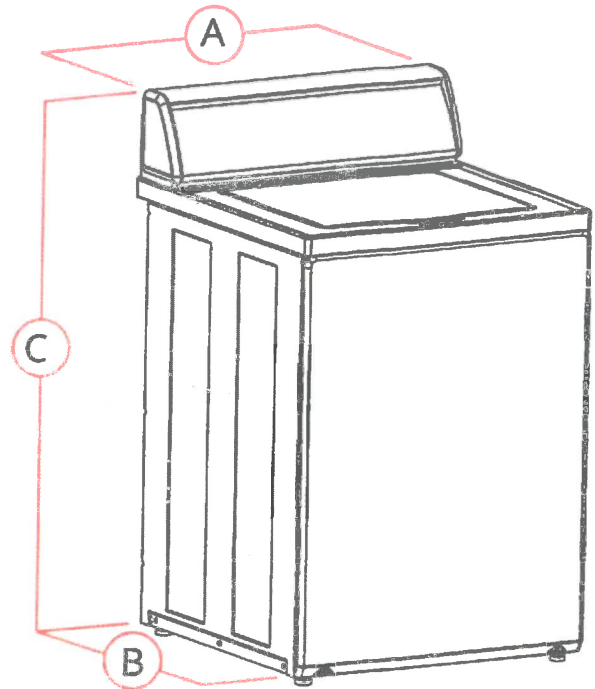
Specifications	
Control Option	Quantum Gold Pro
Color	White
Capacity - lb (kg)	16 (7.3)
Overall Width - in (mm)	25 63 (651)
Overall Depth - in (mm)	28 (711)
Overall Height - in (mm)	43 (1092)
Cylinder Volume - cu. ft. (liters)	3.19 (90.3)
Spin Speed G-Force (RPM)	150 (710)
Motor Size - HP (kw)	0.5 (0.37)
Water Consumption Per Cycle - g (liter)*	28.07 (106)
IWF (Water Factor) - gal/ft³ (liters/liter/cycle)*	8.8 (1.18)
MEF <sub>p</sub> (Modified Energy Factor) ft³/kWh/cycle (Liters/kWh/cycle)*	1.35 (38.2)
Available Water Temperatures	Cold, Warm, Hot
Available Cycles	Normal, Synthetic, Delicate
Electrical Requirements (v/Hz/Ph-Amp)	120/60/1 - 15 Amp
Water Pressure - p.s.i. (bar)	20-120 (1.4/8.3)
Drain	Pump
Cylinder Finish	Stainless Steel
Net Weight - lb (kg)	206 (93.4)
Shipping Weight - lb (kg)	218 (98.8)
Shipping Dimensions Approx. - in (mm)	Width 28 (711)
	Depth 30 (762)
	Height 45 (1143)
Agency Approvals	cULus



A. Overall Width - in (mm)	25.625 (651)
B. Overall Depth - in (mm)	28 (711)
C. Overall Height - in (mm)	43 (1092)

Models	Actuation
SWNNC2SP116TW01	Coin Drop Installed 
SWNNY2SP116TW01	Prep for Card 

\* Average usage based on multiple load sizes and current DOE test protocol. Real usage will vary depending on load size, composition and cycle selectivity.

For the most accurate information, the installation guide should be used for all design and construction purposes. Due to continuous product improvements, design and specifications subject to change without notice. The quality management systems of Alliance Laundry Systems are registered to ISO 9001.



# Rear Control Single Dryer

## Quantum® Gold Pro

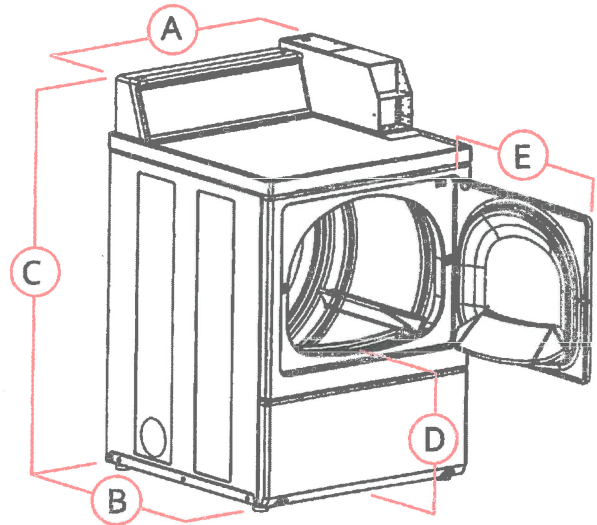
Specifications	
Control Option	Quantum Gold Pro
Color	White
Capacity - lb (kg)	18 (8.2)
Overall Width - in (mm)	26.875 (683)
Overall Depth - in (mm)	28 (711)
Overall Height - in (mm)	43 (1092)
Cylinder Volume - cu. ft. (liters)	7.0 (198)
Motor (Thermal Protected)	0.33 HP
Type Of Gas (Gas Models Only)	Factory equipped natural
Air Outlet Diameter - In (Mm)	4 (102)
Exhaust Airflow - cfm (liters/sec)	220 (105)
Available Cycles	High, Medium, Low, Delicates, No Heat
Electrical Requirements	Electric 120/208-240/60/1-30 amp
	Gas 120/60/1-15 amp
Heating Element	Electric 5350W, 240V 4750W, 208V
	Gas 25,000 Btu
Net Weight - lb (kg)	Electric 150 (68)
	Gas 150 (68)
Shipping Weight - lb (kg)	Electric 161 (73)
	Gas 161 (73)
Shipping Dimensions Approx. - in (mm)	Width 30.5 (775)
	Depth 29.5 (749)
	Height 45 (1143)
Agency Approvals	Electric cULus
	Gas cCSAus



A. Overall Width - in (mm)	26.875 (683)
B. Overall Depth - in (mm)	28 (711)
C. Overall Height - in (mm)	43 (1092)
D. Floor To Door Opening -in (mm)	15.44 (392)
E. Door Swing - in (mm)	23.5 (597)

Model	Voltage/Freq/PH	Actuation	
SDENCRGS176TW01	208-240/60/1	Electric	Coin Drop Installed 
SDGNCRGS116TW01	120/60/1	Gas	
SDENXRG5176TW01	208-240/60/1	Electric	Prep for Coin 
SDGNXRG5116TW01	120/60/1	Gas	
SDENYRGS176TW01	208-240/60/1	Electric	Prep for Card 
SDGNYRGS116TW01	120/60/1	Gas	

Electric dryers come equipped for 208-240/60/1 operation. They can be field converted to operate on 208/60/1 with optional 61928 conversion kit. Gas dryers can be field converted for operation on LP gas with optional 458P3 conversion kit.

For the most accurate information, the installation guide should be used for all design and construction purposes. Due to continuous product improvements, design and specifications subject to change without notice. The quality management systems at Alliance Laundry Systems are registered to ISO 9001.



SPEED QUEEN MULTI-HOUSING LAUNDRY SOLUTIONS

## Top Load Washer

### Quantum® Gold Pro

Prep for Card | Coin Drop Installed

#### Built for Reliable Performance

Speed Queen's two-speed top load washer, defined by its simplicity and its performance, provides everything you need to get the job done – and nothing you don't. Speed Queen's top load washer combines heavy-duty construction with reliable operation proven to stand the test of time. Speed Queen® washers provide maximum energy efficiency and long-lasting performance.

- Touch pad control with sound annunciator
- 27 cycle selections

- Extract speed of 710 RPM spins clothes out drier
- Integrated meter case
- Advanced suspension system
- Easy-to-read digital display
- Cycle programming flexibility
- Multi-level vend pricing
- Individual cycle modifier keys
- Durable stainless steel tub standard
- 3.19 cu. ft. (90.3 liters) wash capacity
- Large capacity meter case standard
- Wash Alert™ capability

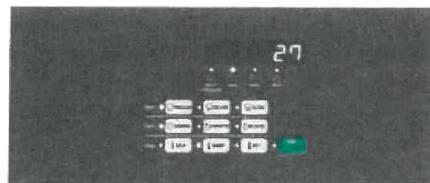

#### Quantum® Gold Pro Control

The Quantum® Gold Pro control delivers a truly premium experience to residents. From intuitive soft touch buttons that walk them through cycle options to multiple actuations (coin, card, mobile) for payment flexibility, this control gives residents the wash and dry options they want, and the revenue potential managers desire.



SPEED QUEEN® MULTI-HOUSING LAUNDRY SOLUTIONS

## Rear Control Single Dryer

### Quantum® Gold Pro

Prep for Card | Coin Drop Installed | Prep for Coin

#### Built for Reliable Performance

Speed Queen's dryer, defined by its simplicity and its performance, provides everything you need to get the job done - and nothing you don't. Speed Queen's single load dryers combine heavy-duty construction with reliable operation proven to stand the test of time. They're designed with less moving parts for one reason: so you'll face fewer maintenance problems and less wear and tear down the road. Speed Queen's dryers provide the perfect balance of heat, airflow and tumble action for optimal performance and efficiency.

- Integrated meter case
- Industry's largest door opening 2.06 sq. ft. (1914 cm<sup>2</sup>)
- Quiet, efficient blower system
- Door is reversible for installation flexibility
- High efficiency exhaust blower with superior airflow 220 cfm (105 liters/sec)
- 100% serviceable from the front
- Space-saving narrow cabinet 26.875" (683 mm)
- Upfront lint filter easy to clean and secured
- Durable galvanized steel cylinder
- Large capacity meter case standard



#### Quantum® Gold Pro Control

The Quantum® Gold Pro control delivers a truly premium experience to residents. From intuitive soft touch buttons that walk them through cycle options to multiple actuations (coin, card, mobile) for payment flexibility, this control gives residents the wash and dry options they want, and the revenue potential managers desire.