

**DEPARTMENT OF
CITY PLANNING**

COMMISSION OFFICE
(213) 978-1300

CITY PLANNING COMMISSION

SAMANTHA MILLMAN
PRESIDENT

MONIQUE LAWSHE
VICE-PRESIDENT

MARIA CABILDO
CAROLINE CHOE
ILISSA GOLD
HELEN LEUNG
KAREN MACK
JACOB NOONAN
ELIZABETH ZAMORA

CITY OF LOS ANGELES

CALIFORNIA



KAREN BASS
MAYOR

EXECUTIVE OFFICES

200 N. SPRING STREET, ROOM 525
LOS ANGELES, CA 90012-4801
(213) 978-1271

VINCENT P. BERTONI, AICP
DIRECTOR

SHANA M.M. BONSTIN
DEPUTY DIRECTOR

ARTHI L. VARMA, AICP
DEPUTY DIRECTOR

LISA M. WEBBER
DEPUTY DIRECTOR

November 28, 2023

Los Angeles City Council
c/ o Office of the City Clerk
City Hall, Room 395
Los Angeles, California 90012

Attention: PLUM Committee

Dear Honorable Members:

**DIRECTOR OF PLANNING TECHNICAL MEMO TO PLUM COMMITTEE FOR
CONSIDERATION OF AMENDMENTS TO THE RECOMMENDED BOYLE HEIGHTS
COMMUNITY PLAN; CF 23-0861; CASE NO. CPC-2016-2905-CPU; ENV-2016-2906-EIR**

This report includes a discussion of topics that were elevated by the City Planning Commission (CPC) during its April 20, 2023 meeting to consider the Boyle Heights Community Plan, with a request by CPC to provide further study and recommendations to the Planning and Land Use Management (PLUM) Committee. This report also includes for City Council consideration of optional modifications (Council Modifications) to CPC's recommendations on the proposed ordinances of the Boyle Heights Community Plan Update, including the New Zoning Code, which were transmitted to the City Council in August 2023. Optional Council Modifications are provided by topic in the subsections of this report and are indicated under the sub-heading "Optional Council Modifications-[Subject Matter]." Additions to a proposed ordinance are indicated by underlined text and deletions to a proposed ordinance are indicated by ~~strikethrough~~.

Table of Contents

| | |
|---|-----------|
| I. CPC Directed Items | 3 |
| A. Minimum Two-Bedroom Set Aside Feasibility and Exemption for Specific Housing Types | 3 |
| B. Rent Schedules..... | 7 |
| C. Local Hire Requirement..... | 10 |
| D. Local Preference Program for Affordable Housing Units | 14 |
| II. Additional Items for Consideration by the PLUM Committee..... | 17 |
| A. Land Use Mix Alternative (Los Angeles River-Adjacent Industrial Alternative)..... | 17 |
| i. General Plan Goals and Policies | 18 |
| ii. General Plan Land Use and Zoning Designations..... | 20 |
| iii. Inclusionary Housing | 27 |
| iv. Form District Modifications..... | 30 |
| v. Sixth Street PARC Project Parcels | 34 |
| vi. New CPIO Subarea for Non-residential Public Benefit Incentives | 35 |
| B. Legacy Small Business Incentives | 38 |
| C. Expansion of CPIO Historic Resources Subarea B..... | 44 |
| D. Technical Modifications to Chapter 1A of the Los Angeles Municipal Code..... | 45 |
| E. Technical Modification to General Plan Designations | 55 |
| Appendix I - IX6 Use District..... | 57 |

I. CPC Directed Items

The City Planning Commission (CPC) at its meeting on April 20, 2023 voted 6-0 to recommend approval of the Boyle Heights Community Plan (Proposed Plan), with a few modifications. The CPC also recommended that Los Angeles City Planning provide additional study for the following topics for City Council's consideration:

- Study the feasibility of increasing the CPIO Subarea A requirement to provide units with 2 or more bedrooms from 30% to 40%.
- Study the feasibility of the CPIO Subarea A requirement to provide units with 2 or more bedrooms for housing for veterans, housing for seniors, and supportive housing, and possibilities to exempt certain housing types.
- Study the feasibility using LAHD Land Use Rent Schedule 6 (HCD) compared to LAHD Land Use Rent Schedule 1 (HUD) for the Boyle Heights Community Benefits Program and the impact each would have on applicants choosing to use the Community Benefits Program versus Density Bonus.
- Study the possibility of a local hire requirement for projects and developments adjacent to the Los Angeles River.
- Study the possibility of a local preference program for affordable housing units in Boyle Heights.

The following section describes the findings from additional studies that were requested by the CPC.

A. Minimum Two-Bedroom Set Aside Feasibility and Exemption for Specific Housing Types

Background

At the April 20, 2023 City Planning Commission (CPC) meeting, Commissioners directed the Department of City Planning to study two additional considerations regarding family-sized units before the Proposed Plan is presented to the City Council's Planning & Land Use Management Committee. The Proposed Plan requires housing projects seeking to use the incentives in the Boyle Heights Community Benefits Program (e.g. FAR and height bonus, density bonus, parking reductions, etc.) to include 30% of the total units with two or more bedrooms. The CPC requested that City Planning evaluate the possibility of increasing the 30% requirement to 40% of total units. In addition, the Proposed Plan provides an exemption from this requirement for 100% affordable housing projects, therefore these types of projects can access incentives without having to meet the two or more-bedroom requirement. Based on public comment heard during the CPC hearing, the Commission requested that City Planning evaluate the possibility of narrowing this exemption to only include certain types of 100% affordable projects, such as Permanent Supportive Housing, Veteran Housing, and Senior Housing, as these types of housing are known to have higher demand for smaller unit types such as studios and one-bedroom units.

City Planning retained the economic consulting services of AECOM to assess the economic feasibility of these additional considerations for the proposed Boyle Heights Community Benefits Program; and provide feedback for City Council's consideration to determine whether to adjust the program requirements.

Topic: Number of Family Sized Units Required

A market analysis and interviews with developers revealed initial findings that reinforced the need for larger housing units in Boyle Heights, as well as developer's concerns over adding additional requirements that may have an impact on the feasibility of housing developments. Demographic patterns in Boyle Heights indicate that residents of the CPA continue to live in household sizes that are larger than the citywide average, yet at the same time, housing units are smaller than the citywide average, resulting in a large portion of overcrowded households in Boyle Heights (30%) compared to citywide (13%). The study also found that about 44% of existing multifamily housing stock in Boyle Heights consists of 2-bedroom units or larger (family sized), highlighting the historical market trend towards larger housing units. The proportion of family sized units was found to be greater for affordable housing (45%), than for market rate housing (35%).

AECOM completed a pro-forma financial analysis to test the development feasibility of 40% compared to 30% of total units with two or more bedroom units, for three prototypes which simulate the economic conditions a developer would consider in deciding whether to pursue a project. The results of the pro-forma analysis indicate that an increase in the requirement for family-sized units from 30% to 40% of the total would have an adverse impact on the potential feasibility of residential and mixed-use projects, and of mixed-income development in Boyle Heights. Studio and one bedroom apartments command a higher market rate rent than two and three bedroom units, with the latter having a notable discount in achievable rent per square foot. Increasing the requirement for larger unit sizes may result in fewer studio and one bedroom units as that floor area is instead used to accommodate additional larger units. The result of substituting studios for three bedroom units results in fewer total units and a lower average rent for the combined residential uses. Therefore, reducing monthly revenue by substituting smaller units for larger units negatively impacts the capitalized value and pushes many prototype scenarios to be infeasible. The most likely scenario in Boyle Heights in the near future is one with higher market rents and construction costs. By increasing the family sized unit requirement from 30% to 40%, the feasibility and ability to develop a variety of affordable housing on a range of development types, is generally reduced to only those with the highest density and the lowest affordable set-asides (10% and Acutely Low and 11% Extremely Low).

The net impact on the number of affordable and family sized affordable units was also analyzed through this study. The table below demonstrates the net increase or decrease in overall units as well as affordable units when the requirement is raised from 30% to 40%. Table A.1 below demonstrates a 45 unit project with five units set aside as restricted Extremely-Low Income units. With a 30% two bedroom requirement, 14 units would be required to have two or more bedrooms;

with a 40% two bedroom requirement, that number increases to 18 units. Because of existing requirements that restricted units be distributed throughout a development and be similar in size to market rate units, a proportional number of two bedroom units would likely be set aside for the restricted affordable units and the market rate units. With a 30% requirement, this yields two affordable two bedroom units and 12 market rate two bedroom units; a 40% requirement yields two affordable two bedroom units and 16 market rate two bedroom units.

| Table I.A.1: Comparison of 30% vs. 40% 2 bedroom requirement | | |
|---|---|---|
| | 2 bedroom requirement set at 30% | 2 bedroom requirement set at 40% |
| Total Units in Project | 45 | 45 |
| Total Affordable Units (11% ELI) | 5 | 5 |
| Total 2 BR Units | 14 | 18 |
| Total 2 BR Affordable Units | 2 | 2 |
| Total 2 BR Market Rate Units | 12 | 16 |

While the overall number of family-sized units may increase in a project, because the percentage of affordable units typically seen in a mixed-income development is the lowest set-aside, at 10-11%, the additional family-sized units at the development scale typically seen in Boyle Heights may only yield zero or one additional affordable family-sized unit.

Recommendation on Topic: Number of Family Sized Units Required

It is recommended that the Proposed Plan’s requirement for mixed-income housing projects to provide 30% of housing units as two-bedroom or greater be sustained as an economically viable approach to bolstering family-sized housing units in Boyle Heights. While considering the impact that the family sized housing unit requirement has on the production of overall units, it is important to take into account the balance between maximizing the production of overall market rate and affordable housing units, while meeting the specific needs of varying household sizes. When the requirement is raised to 40%, the total number of housing units in a project may be reduced to accommodate the higher number of larger sized units within the same building envelope. However, in general more family-sized units are produced, though not all of the family-sized units will be affordable units.

One of the City’s overarching policy objectives is to increase housing production and incentivize the production of affordable housing. Based on the analysis and demonstrated above, increasing

the two bedroom requirement from 30% to 40% will further limit project feasibility and decrease the overall potential number of housing units, to accommodate the larger unit sizes, thus undermining citywide housing goals. In addition, the yield of affordable family-sized units is not likely to substantially increase due to the scale of development seen in Boyle Heights. These impacts must be fully considered if the required percentage of family sized units is increased. Therefore, it is recommended that the Proposed Plan's requirement for 30% of the units to be two-bedroom, or greater be sustained.

Topic: Revisions to the Exemption for 100% Affordable Housing Projects

While larger affordable units are desirable for families, there appears to be less demand for larger units among certain subcategories of affordable housing, specifically Permanent Supportive Housing (PSH), and housing for Seniors, Veterans, and Transitional Age Youth. Amongst these types of housing, most projects studied did not have at least 30% of units with 2 or more bedrooms. In addition, organizations whose business model differs from standard income based and family affordable housing types can find it more difficult to meet a family-sized unit requirement, oftentimes due to different funding and financing models. Additional requirements to qualify for incentives are also unpopular with market rate and some affordable housing developers, further challenging the development of housing developments in Boyle Heights.

It is important to consider that there are housing projects and public funding models that target specific populations, where a family-sized unit requirement would hinder their feasibility. In particular, housing projects that are funded and designated for special populations such as Permanent Supportive Housing, and housing for Veterans, Seniors, and Transitional Age Youth. Many developers for these types of projects utilize modular housing, and may have difficulty making projects with a wider range of unit types work with their business model, which rely on off-site assembly of standardized unit types in order to reduce costs and maintain affordability. Developers expressed that such an onerous requirement for all types of affordable housing models would only make these specialty types of affordable housing projects more challenging, time consuming, and costly to develop.

While the need for larger family sized units is still prevalent in Boyle Heights, there is less of a demand for larger units among certain subcategories of housing, specifically Permanent Supportive Housing, housing for Veterans, Seniors and Transitional Age Youth. The vast majority of these households have only one member, and could be considered for an exemption from the family size unit requirement. Further, interviews with developers and analysis shows that the 2 bedroom requirement may add barriers that make these subcategories of affordable housing infeasible.

Recommendation on Topic: Revisions to the Exemption for 100% Affordable Housing Projects

It is recommended that the two-bedroom requirement be applied to 100% affordable projects, with the exception of Permanent Supportive Housing, housing for Veterans, Seniors and Transitional

Age Youth. The technical edits to the Boyle Heights CPIO necessary to effectuate this change provided below, with additions to the ordinance indicated by underlined text and deletions are indicated by ~~strikethrough~~.

Technical Amendment I.A: Two-bedroom Set Aside Exemption

Amend the Boyle Heights Community Plan Implementation Overlay (CPIO) Chapter II (*Community Benefits Program Subarea*) Section II-2. (*Eligibility*) to read as follows:

2. Dwelling Unit Mix and Location. A minimum of 30% of the dwelling units for an Eligible Housing Development shall be two bedrooms or larger, and LAHD shall determine the location of the restricted affordable units within the development. Projects that provide 100% of the units as deed-restricted housing for Veterans, housing for Seniors, housing for Transitional Age Youth, or Permanent Supportive Housing, ~~in the development as deed-restricted affordable units,~~ except for a manager's unit, are exempt from this requirement.

B. Rent Schedules

Background

At the CPC meeting, the Commissioners also requested that City Planning study the feasibility of using Los Angeles Housing Department's Rent Schedule 6 compared to Rent Schedule 1 for the Boyle Heights Community Benefits Program, and present some considerations to City Council's PLUM Committee. The Boyle Heights CPIO District includes a permanent affordable housing incentive program that replaces the currently in-effect Transit Oriented Communities (TOC) Guidelines for properties within the Boyle Heights CPIO District per Measure JJJ. Although the Boyle Heights CPIO does not include language to prescribe a specific rent schedule, it does state that projects that use the CPIO Incentive Program set rents as determined by the Los Angeles Housing Department (LAHD). As LAHD now uses HUD's Schedule 1 for projects with incentives, projects that use the Boyle Heights CPIO's affordable housing incentives would also default to using Schedule 1.

The Transit Oriented Communities Guidelines (TOC Guidelines), went into effect in 2017 as part of the voter-approved Measure JJJ. Since it went into effect in 2017 the TOC Guidelines has incentivized housing production at deeper levels of affordability than any other planning entitlement, including Density Bonus. The program's combination of incentives and requirements has proven successful at increasing housing production, while also producing a higher percentage of affordable units year after year.

When implementing affordable housing covenants that are established for individual mixed-income housing projects, the Housing Department, per Measure JJJ and the definition of On-Site Affordable Units per Section 12.22 A.31(g) of the Los Angeles Municipal Code, has the authority

to establish the rent levels that will be required for onsite affordable housing units. Since the establishment of the TOC Guidelines, the Housing Department has used “Schedule 6,” and “Schedule 7” developed pursuant to regulations by the California Housing Department (HCD). These schedules are similarly used for Density Bonus projects, as mandated by State Law. In October 2022, the Housing Department began to use “Schedule 1” developed pursuant to regulations by the U.S. Department of Housing and Urban Development (HUD). Maximum allowable rents under Schedule 1 are higher than those provided under Schedules 6 and 7.

There is a growing concern that the change in rent schedule for TOC projects would have a significant impact on lower-income households because of the increase in maximum allowable rent levels. The issue was also raised when the Downtown Los Angeles Community Plan and Hollywood Community Plan went through the City Council adoption process in May 2023, as both community plans include a permanent affordable housing incentive program that replaces the TOC Guidelines. As noted in the tables below, the HUD rents (Schedule 1) are notably higher than the HCD rents (Schedule 6).

Table I.B.1 Schedule 1 (HUD schedule) - Maximum Allowable Rent Levels

| Rent Level | Bedroom Size | | | | | |
|---------------------|--------------|---------|---------|---------|---------|---------|
| | Single | 1-BR | 2-BR | 3-BR | 4-BR | 5-BR |
| Extremely Low (30%) | \$626 | \$715 | \$805 | \$894 | \$966 | \$1,038 |
| Very Low (50%) | \$1,043 | \$1,191 | \$1,340 | \$1,489 | \$1,609 | \$1,728 |
| Low (80%) | \$1,669 | \$1,906 | \$2,145 | \$2,383 | \$2,574 | \$2,764 |
| Moderate (120%) | \$2,503 | \$2,859 | \$3,216 | \$3,573 | \$3,861 | \$4,146 |
| Workforce (150%) | \$3,128 | \$3,574 | \$4,020 | \$4,466 | \$4,826 | \$5,183 |

Table I.B.2 Schedule 6 (HCD schedule) - Maximum Allowable Rent Levels

| Rent Level | Bedroom Size | | | | | |
|---------------------|--------------|---------|---------|---------|---------|---------|
| | Single | 1-BR | 2-BR | 3-BR | 4-BR | 5-BR |
| Extremely Low (30%) | \$461 | \$527 | \$592 | \$658 | \$711 | \$763 |
| Very Low (50%) | \$768 | \$878 | \$987 | \$1,097 | \$1,185 | \$1,272 |
| Low (60%) | \$921 | \$1,053 | \$1,185 | \$1,316 | \$1,422 | \$1,527 |
| Moderate (110%) | \$1,689 | \$1,931 | \$2,172 | \$2,413 | \$2,606 | \$2,799 |

Similarly, if the projects under the Boyle Heights CPIO were to use Schedule 1, the rents for participating affordable housing units would be notably higher than they would be using Schedule 6. Stakeholders and Council Members have expressed concern that the use of Schedule 1 will result in lower-income households being priced out of being able to rent these new affordable housing units, and particularly from projects that use unsubsidized (privately-financed) affordable units.

The table below further highlights the difference in maximum allowable rent between Schedule 6 to Schedule 1.

Table I.B.3 Rent Schedule Established Rents Comparison

| Low Income Households | Maximum Income Level for 1-person household | Maximum Rent Level for Studio | Maximum Income Level for 3-person Household | Maximum Rent for a 2 bedroom Unit |
|-----------------------|---|-------------------------------|---|-----------------------------------|
| Schedule 6 (HCD) | \$66,750 | \$921 | \$85,800 | \$1,185 |
| Schedule 1 (HUD) | \$66,750 | \$1,669 | \$85,800 | \$2,145 |

For low-income households, the change from Schedule 6 to Schedule 1 represents an 81% rent increase for renting a studio (for a 1-person household) or renting a two-bedroom apartment for a three-person household.

There is also interest in further discussing the change in the rent schedule for TOC projects at a broader citywide level than just as it applies to the affordable housing incentives in the Boyle Heights Community Plan and the recently adopted Downtown Los Angeles Community Plan and Hollywood Community Plan. On May 10, 2023, Councilmember Raman introduced a motion (CF-23-0490), which was seconded by Councilmember Hernandez, that instructed the Los Angeles Housing Department, with support from the City Attorney, to report back with a plan for changing the TOC Guidelines back to Schedule 6 or 7, and to also include additional options to minimize rent amounts for lower-income tenants of 100% affordable housing projects, while ensuring that those projects meet funding source requirements. Council’s Housing and Homelessness Committee considered and approved the motion at their June 21, 2023 meeting, and City Council subsequently approved the motion at its June 30, 2023 meeting.

Recommendation on Topic: Rent Schedules

At the time of drafting this report the Housing Department’s report back to the Council’s Housing and Homelessness Committee is still pending. If the City Council seeks to establish that the Boyle Heights affordable housing incentive system uses HCD Rent Schedule 6, ahead of resolving the citywide process currently underway, it can incorporate the technical language provided below. The Council may also request that the City Attorney work with City Planning staff to incorporate any recommended changes to the final ordinances to address any consistency issues with the ongoing citywide reports and recommendations under CF-23-0490, or with Measure JJJ.

If the City Council chooses to address rent schedules in the Boyle Heights CPIO, an option for City Council’s consideration is to make the following modifications to Exhibit D1 of the PLUM Transmittal (Boyle Heights CPIO District), which is presented below for Council’s consideration. Additions to the ordinance are indicated by underlined text and deletions are indicated by ~~strikethrough~~. In addition, the City Council should request that the City Attorney provide a report to the Council, at the time the final Boyle Heights ordinances are presented to Council for adoption, that addresses any legal or consistency concerns with respect to prescribing Rent Schedule 6 in Boyle Heights.

Technical Amendment I.B: Affordable Housing Rent Schedules

Amend the Boyle Heights Community Plan Implementation Overlay (CPIO) Chapter I (*Function of the CPIO District*) Section I-4. (*Definitions*) to read as follows:

Restricted Affordable Unit. A Dwelling Unit for which rental amounts are restricted so as to be affordable to and occupied by Acutely-Low, Extremely-Low, Very-Low, or Lower-income households, ~~as determined by the Los Angeles Housing and Community Investment Department or its successor agency~~ and Mixed-Income projects shall comply with income ranges as defined by the California Health and Safety Code Sec. 50052.5 or California Health and Safety Code Sec. 50053.

C. Local Hire Requirement

Background

At the April 20, 2023 CPC meeting, the City Planning Commission also directed City Planning to evaluate the possibility of a local hire requirement for projects and developments in the industrial district adjacent to the Los Angeles River. The area is currently designated for light and heavy industrial uses, and developed predominantly with lower-scale warehouse-type buildings with uses such as offices, textile manufacturing, and food processing. As proposed by City Planning and as recommended by the CPC, this area would be designated for light industrial land uses, promoting a range of employment opportunities, similar to uses that exist today. In an effort to improve the environmental quality for nearby residents, the Proposed Plan prohibits new heavier industrial and noxious uses from opening in the area. In addition, similar to today, the only housing that would be allowed would be through the adaptive reuse of existing buildings, through a Conditional Use Permit process.

In tandem, the Proposed Plan includes several policies and programs that support local employment opportunities, in particular Land Use Goal 13, which calls for “Industrial land located adjacent to the Los Angeles River Rail areas provides a dynamic concentration of ‘High Road Career Ladder’ and local jobs and small businesses.” Proposed Program 20 also points to the desire to “Develop partnerships to create business outreach programs targeting local schools for student and adult participation in business apprenticeship and internship programs...” highlighting the need heard from the community in building pathways to employment, and the potential of land use policy as a tool to achieve this end.

These antecedents led to the CPC’s request for City Planning to explore the possibility of targeting Boyle Heights residents for the potential jobs created in the construction and operation of new projects and businesses near the Los Angeles River. In order to better understand how a local hire requirement could work at a neighborhood level, such as in Boyle Heights, a preliminary

investigation was conducted that examined existing programs within the City of Los Angeles, as well as in other jurisdictions.

Findings

Several public entities, including the City of Los Angeles, use various types of policies, programs and incentives to encourage local resident hiring. Many of these local hiring programs are established through ordinances or statutes, while others may be incorporated into development agreements, financing requirements, construction contracts, or project labor agreements. Consequences for non-compliance or violation of local hiring laws vary by jurisdiction, while in others, compliance is optional, and incentive based. The following is a summary of the research and potential considerations.

City of Los Angeles

In 2016, City of Los Angeles voters approved Measure JJJ, also known as the “Build Better LA Initiative,” to address the homeless and affordable housing crisis, which added a provision to the City’s municipal code to require developers of certain residential projects to either provide on-site affordable units or pay an in-lieu fee, into the City’s Affordable Housing Trust Fund. The Measure also requires projects that seek certain zone changes or General Plan Amendments comply with Labor Standards including using licensed contractors, paying prevailing wages, and hiring trained workers and apprentices from local and disadvantaged areas. It also requires a good faith effort to ensure that 30% of construction worker hours are performed by permanent residents of Los Angeles, and 10% are performed by Transitional Workers, as defined by LAMC 11.5.11(j), whose primary place of residence is within a 5-mile radius of the covered project.

Employment and Workforce Development Department (EWDD)

The City of Los Angeles’ Employment and Workforce Development Department (EWDD) serves the Boyle Heights CPA through its WorkSource and YouthSource Centers, and through programs that offer employment services and broad support in building businesses and careers. The EWDD currently operates 16 WorkSource Centers throughout the City, including one located within the Boyle Heights CPA a block from the Metro E Line Pico/Aliso Station. The Center offers local residents job training; skills workshops such as for resume building and interview preparation; career guidance, job referrals, and employment matching services; as well as access to computers and phones. The Center also supports local businesses with job advertisements, referrals, customized recruitment services, interview facilities, and on-the-job and pre-employment training. Similarly, EWDD’s YouthSource Centers, which includes the local Boyle Heights Technology Youth Center, provides residents between the ages of 14 to 24 with support and resources designed to help those that are not in school and not working. This includes help finding the classes they need to graduate, pathways to pursue higher education, as well as opportunities for paid internships, occupational skills training, and job readiness programs. The center also provides access to computers, tutoring, mentoring, and counseling.

In addition to these centers, Boyle Heights residents and local businesses are supported by the various targeted workforce development programs and services such as Hire LA's Youth Program, LA: RISE, and the Veteran's Initiative Program (VIP). In Hire LA's Youth Program, the City partners with the City's business community, local schools, community colleges and community organizations to prepare young adults for the modern workplace, and develop long-term employment opportunities for LA's emerging workforce. LA: RISE is a partnership between the City and County's workforce development system with nonprofit and for-profit employers to help those with high barriers to employment, such as those experiencing homelessness, to get jobs and stay employed. VIP is a veteran's employment program designed to help veterans secure employment and or education through community partnerships with employers and colleges.

The Boyle Heights Community Plan also identifies future programs to enhance the role of EWDD in building greater access to employment opportunities for Boyle Heights residents. One such program is a future Business Outreach and Mentorship Program to develop partnerships with businesses to create outreach programs that target local schools for adult and student participation in apprenticeship and internship programs.

Other Jurisdictions and Local Hire for Construction Projects

Washington DC

The First Source Employment Program in the District of Columbia provides that 51% of new jobs created with public funding go to DC residents where the projects are between \$300,000 and \$5 million. The program applies to both government-assisted construction and non-construction projects, as well as retail or commercial tenants that are beneficiaries of government assistance. For construction projects monitoring and reporting is required until the final certificate of occupancy is issued, for non-construction projects it is required as long as the benefit is being received, and for retail and commercial tenants, for five years following the commencement of the tenant's initial lease date.

San Francisco

Established in 2011, the San Francisco Local Hiring Policy requires that public works or improvement construction projects worth an estimated \$600,000 or more include San Francisco resident participation levels of 50% for total work hours within each trade. Contractors and developers who exceed the 50% threshold, may be provided with financial and non-financial incentives or entitlements. Those who fall short of meeting these requirements must pay the city an amount equal to the prevailing wage for journey persons or apprentices, at a rate that equates to the number of hours below the threshold.

Seattle

Enacted in 2015, the Priority Hire Ordinance applies to city construction projects in excess of \$5 million. Project specific goals are set at no less than 20% and will adjust annually to increase to

40% by 2025. The ordinance gives priority to residents of economically disadvantaged neighborhoods within Seattle by zip code.

Boston

The Boston Residents Construction Employment Standards, established by Mayoral Executive Order in 1983, and amended with new employment standards, requires private development projects over 50,000 square feet and any public development project use good faith efforts to ensure that at least 51% of total work hours of journey people and apprentices in each trade go to Boston residents. The ordinance is monitored by the Boston Residents Jobs Policy office and the Boston Planning and Development Agency.

St. Louis

St. Louis established a local resident project labor hour goal of 20% to be performed by City residents, for the City's public works contracts that are worth an estimated base value of one million dollars or more. This ordinance also establishes apprenticeship training for groups under-represented in the skilled workforce in the construction industry and requires 25% of all labor hours include women and targeted minorities. If St. Louis residents are also minorities and or women, their labor hours can count for both requirements, which is administered and monitored by the St. Louis Agency for Training and Employment.

New Orleans

The "Hire NOLA" Ordinance was passed by New Orleans City Council in 2015, which requires contractors on public city projects with an estimated value above \$150,000 make a good faith effort to ensure that 30% of total work hours go to New Orleans residents. There was a gradual increase in this percentage and it currently stands at its goal of 50% by the year 2020. The ordinance provides support for non-compliant contractors, but eventual failure to meet the local hiring standards constitutes a breach of contract.

Baltimore

The Local Hiring Law provides that 51% of all new hires used to complete a project must be residents of Baltimore. In effect since 2013, the law applies to all city contracts exceeding \$300,000, and any private entities involved in a project that benefits from more than \$5 million in city subsidized assistance.

Recommendation on Topic: Local Hire

No action is recommended with respect to addressing local hire provisions within the Boyle Heights Community Plan. There are some considerations that need to be further explored to determine whether a local hiring policy would fall primarily under the purview of City Planning, and within the scope of an industrial district within Boyle Heights Community Plan. As seen by these examples, local hiring programs enacted by public entities are generally focused on ensuring that local residents at the citywide level (with the exception of Seattle) are the primary labor pool drawn from during the construction phase (with the exception of Washington DC) of

larger, and typically publicly funded projects. Access to public works contracts, grant funding, and other types of public subsidies are linked to compliance with local hiring policies, and enforced through tools such as in lieu fees and penalties; and or contract terminations.

The Community Plan's ordinances are contained within Chapter 1A of the Municipal Code and are chiefly oriented around land use and zoning. Thus, while the zoning regulations can establish what the allowed uses or building activities will be, employment activities are generally regulated under local, state and federal employment laws; and implemented outside of the planning and development process. Research conducted by City Planning did not yield a viable example to build upon that embeds local hiring requirements into base zoning and land use regulations at either a citywide or neighborhood level. Furthermore, in almost all the aforementioned examples, local hire preference was only during the construction phase of a development project, and not for the operation of a particular future business housed in a development. Good faith efforts in local recruitment can be included in and enabled through development agreements between municipalities, developers, and businesses, but as previously stated, incorporating local hire requirements into zoning and land use is not common practice. Further research should be conducted to better understand how this practice would be implemented as well as the legal and practical implications of requiring businesses to hire from a local labor force as a zoning and land use requirement, and to consider whether such a requirement should be applied more broadly across the City.

Should City Council choose to implement a local hire requirement within Boyle Heights, City Planning recommends that this be done as a future study and potential program at a Citywide level in collaboration with the Economic and Workforce Development Department, and any relevant City Departments and local agency partners to ensure adequate enforcement and implementation of the program.

D. Local Preference Program for Affordable Housing Units

Background

At the April 20, 2023 meeting, the City Planning Commission also directed City Planning to further research the possibility of a Local Preference Program for Affordable Housing Units, so when new restricted affordable units become available within Boyle Heights, Boyle Heights residents are given priority for those units.

In early 2023, the Los Angeles Housing Department (LAHD) provided a report to City Council ([CF 22-0651](#)) outlining a proposed policy for a City of Los Angeles Local Preference Policy ("City Local Preference"). This program would require developers to prioritize applicants that live or work in the City of Los Angeles for restricted affordable housing units.

Several other cities in the Los Angeles region and California maintain a local preference or priority program for applicants who work or live in the respective jurisdiction. These programs often prioritize tenants displaced by no-fault evictions or displaced by government actions. In other cases, priority is given to applicants who either live or work in the City currently, or live in areas that are at high risk of gentrification or displacement. Where geographical preference is given, it is often within a specific political district or within Census tracts high on a Displacement Risk Index or done at a jurisdiction-wide scale. For example, the City of Santa Monica¹ created a waitlist for applicants who wish to be selected for affordable housing units in private developments. The process gives priority to current households in Santa Monica who have been or will be displaced, due to natural disasters, building demolition, or Ellis Act evictions, among other circumstances. Second priority is given to households that currently live in Santa Monica or work in Santa Monica at least 25 hours a week. Third priority is given based on order of application.

Similar to programs in other jurisdictions and as discussed in the LAHD report-back previously mentioned, a Los Angeles local preference policy would likely apply Citywide to prioritize residents that currently live and/or work within the City of Los Angeles, rather than in specific neighborhoods. In pursuing the establishment of a local preference system, the City has to consider whether a neighborhood-specific local preference program could be inconsistent with the federal Fair Housing Act by potentially reinforcing historic segregation patterns that are tied to the legacy of redlining that limited financial investment and opportunities to purchase housing, as well as how a local preference system relates to the City's Affirmatively Furthering Fair Housing (AFFH) obligations established under the Housing Element, and under State Law.

The fundamental goal of a local preference system for Boyle Heights would be to ensure that local residents who may be priced-out or evicted from housing under a variety of circumstances have access to new affordable housing within their community, and are thus able to remain close to employment, community institutions such as schools and churches, etc. However, since the demographic make-up of the Boyle Heights CPA is predominantly Latino/a/e residents, a neighborhood-specific program could be considered to have a discriminatory effect because it could result in a disparate impact on a group of individuals, or could create, increase, reinforce, or perpetuate segregated housing patterns, based on membership in a protected class. Additionally, in order to move forward with a neighborhood-specific local preference program, the City would need to demonstrate that a local preference program is the only tool that could prevent displacement, and that all other options that are less discriminatory do not address displacement.

The Boyle Heights Community Plan includes several strategies that address displacement, including a requirement for projects that use the proposed Community Benefits Program or another incentive program to replace demolished units subject to the Rent Stabilization Ordinance (RSO) with Lower Income units at a 1:1 ratio, with a covenant for a term of 99 years. The Plan also includes a future implementation program, in collaboration with the Los Angeles Housing Department (LAHD), to explore the creation of a right to return program. This program would

¹ City of Santa Monica Housing Division (<https://santamonicahousing.org/>), accessed July 20, 2023.

ensure that tenants of any RSO units or an On-Site Restricted Affordable Unit that is demolished or vacated for purposes of a proposed development project would be granted first right to return for the replacement units. This is currently a requirement under SB 330 and SB 8, but as it is set to expire in 2030 the Boyle Heights Community Plan identifies a future program to establish a permanent First Right to Return program.

Recommendation on Topic: Local Preference

No additional action is recommended with respect to establishing a local preference system, however some technical amendments are recommended to the Boyle Heights CPIO to bolster the manner in which new affordable housing units will be advertised within their respective neighborhoods.

Currently the Housing Department is pursuing a Citywide local preference system. At this time, it is not envisioned that the citywide system would provide local preference at the neighborhood-level. As previously noted, careful consideration should be given as to how neighborhood-level local preference program relates with the Fair Housing Act. In addition, the Council may continue to work with the Housing Department to develop and refine the local preference ordinance that is already underway.

In the absence of a neighborhood-specific local preference policy, City Council may still take steps to prioritize Boyle Heights residents for vacated and new restricted affordable units. City Council may amend the Boyle Heights Community Plan Implementation Overlay (CPIO) District to include a requirement in CPIO Subarea A that developers and project owners make a good faith effort to advertise the available units within a specified distance of the housing development. Further, City Council may specify the type and number of locations where the housing units must be advertised, such as libraries, recreation centers, public schools, or other businesses. This would help ensure that developers and project owners are adequately advertising the available units at locations frequented by residents and those who work in Boyle Heights.

Technical Amendment I.D: Local Advertisement of Affordable Housing Units

Request that the City Attorney work with City Planning to incorporate regulations within the Boyle Heights CPIO Subarea A that developers and project owners make a good faith effort to advertise the available units within a specified distance of the housing development, and require that advertisement in English and Spanish occur at the development location, and at locations such as libraries, community or recreation centers, at public schools, relevant online platforms, and at other locations frequented by local residents or workers.

Amend the Boyle Heights Community Plan Implementation Overlay (CPIO) Chapter II (*Community Benefits Program Subarea A*) Section II-2. (*Eligibility*) to add the following:

3. Advertisements. In order to demonstrate a good-faith advertising effort, the developer or owner of an Eligible Housing Development shall advertise the available deed-restricted affordable housing units to meet the following criteria:

- a. Advertisements shall be posted in both English and Spanish, at a minimum 12 point font and minimum 8.5x11 size;
- b. Advertisements shall be posted for a minimum of 60 days;
- c. Advertisements shall include a working phone number and email address for interested applicants to contact the developer, owner, or operator;
- d. Advertisements should include website information for the Los Angeles Housing Department (LAHD) and the development project, if applicable;
- e. Advertisements should include the number of available affordable units and the income limits for applicants to be eligible for those units;
- f. Advertisements shall be posted in the following locations:
 - i. All public libraries located within a 1.5 mile radius of the project site;
 - ii. At minimum two LAUSD schools or publicly operated recreation centers within a 1.5 mile radius of the project site;
 - iii. At the exterior fence or wall of the project site in a publicly visible and accessible location.

II. Additional Items for Consideration by the PLUM Committee

The following sections include discussions and optional Council Modifications to CPC's Recommendations for consideration by the PLUM Committee. The following sections represent emerging items that were raised to City Planning staff by staff members of Council District 14, or through various letters and discussions.

A. Land Use Mix Alternative (Los Angeles River-Adjacent Industrial Alternative)

Background

Throughout the Boyle Heights Community Plan update process, a wide range of input has been given on the area adjacent to the Los Angeles River and existing railroad tracks. The area is currently designated for Light and Heavy Industrial uses and is developed predominantly with lower-scale warehouse type buildings with uses such as offices, textile manufacturing, and food processing. This area has received increased attention during the planning and construction phases of the new Sixth Street Viaduct, and as efforts to complete a park beneath the viaduct continue. Over the past several years of outreach, feedback on the future vision for this area has been mixed. Some have affirmed the area's role in providing opportunities for future employment, while others were interested to see housing, including affordable housing developed in the future.

The Draft EIR for the Boyle Heights plan was published in July 2022, and included a Project Alternative (or scenario), called “Alternative 3 - Land Use Mix Alternative”, where the zoning for this area of the CPA would permit housing and more conventional commercial uses. Under Project Alternative 3 in the Draft EIR, the existing industrial area near the Los Angeles River would be changed to a combination of “Hybrid Industrial” and “Commercial-Mixed Use” zoning, both of which would allow for residential uses. This alternative was presented for public consideration at the Public Hearing for the Boyle Heights plan, as well as to the City Planning Commission. The City Planning Commission has recommended the continuation of light industrial activities within this area, citing the need to have space for employment activities, as well as concerns that housing development within this industrial area would create new public health and land use inconsistencies, noting in particular the high level of truck traffic experienced within the area.

In the weeks following the CPC’s determination, Council District 14 expressed an interest in pursuing Council consideration of changes to the Boyle Heights Community Plan that would allow for housing within the subject area, with various stipulations, including refinement of General Plan Land Use and zoning to allow for Hybrid Industrial/Industrial Mixed-use designations that allow for ongoing light industrial uses as well as new housing uses; the establishment of an inclusionary housing obligation; refinements to zoning districts to address building scale transitions; and an expanded set of public benefits for non-residential projects within the Community Benefits Program. Following is a discussion on each of these topics as well as a comprehensive set of amendments that can be made by the Council to effectuate these changes.

i. General Plan Goals and Policies

Several of the Goals and Policies enumerated within the Boyle Heights Community Plan text, as well as the Framework Element speak to the preservation and bolstering of industrial land, specifically within the subject river-adjacent area. Should the Council seek to amend the Community Plan to allow for housing uses within this context, the following Goals and Policies should be re-worded and/or removed:

Boyle Heights Community Plan

LU GOAL 12

~~INDUSTRIAL LAND SUPPORTING PRODUCTION AND DISTRIBUTION USES IS PRESERVED AND IMPROVED AS A LOCAL SOURCE OF EMPLOYMENT OPPORTUNITY AND ECONOMIC PROSPERITY, WHILE INTRODUCING OPPORTUNITIES FOR NEW HOUSING IN PROXIMITY TO REGIONAL JOBS CENTERS AND INFRASTRUCTURE.~~

~~LU 12.1 Maintain existing industrial land for both traditional and~~ Allow for housing to co-locate near emerging clean industries that provide sources of employment

for the local workforce as well as opportunities for small business creation and expansion.

LU 12.2 Maintain industrial land, facilities, and infrastructure necessary for warehousing and distribution centers to serve the region expeditiously and reliably.

LU 12.3 ~~Support the continued use and function of industrial districts for wholesale activities-~~ Establish the potential for vertical integration of industry and wholesale activities with commercial and residential uses to ensure that businesses in Boyle Heights and throughout Los Angeles have direct access to goods from around the world.

LU 12.4 Attract and sustain uses involved in textile manufacturing in support of the region's fashion industry and as a source of local jobs.

LU 12.5 Enhance the role food and beverage processors and distributors play locally by encouraging related businesses to cluster around a food hub that integrates growers, producers, wholesalers, retailers, and food markets within a publicly accessible setting.

LU 12.6 Ensure that industrial districts provide a balance of large facilities and small workplaces in order to accommodate a diverse set of industries and support businesses at all stages of growth.

LU 12.7 ~~Discourage uses that detract from the productive function of industrial districts, such as~~ Encourage mixed-use development along the Los Angeles River, including residential in combination with commercial, light industrial, manufacturing, and creative uses, in-lieu of single-use residential development and large, free-standing retail establishments.

LU 12.8 Discourage new distribution centers and other uses that generate high volumes of truck traffic from locating in areas without direct access to the Metro Countywide Significant Truck Arterial Network or near residential uses.

Framework Element:

- a. In Chapter 3 of Framework Element under the Land Use section, Industrial policies, add the following language after policy 3.14.9 to read:
3.14.10 Within the Downtown Community Plan Area and in portions of the Boyle Heights Community Plan Area adjacent to the Los Angeles River, promote the development of a mix of uses to facilitate innovation, development of new markets, and accommodate evolving industries over time, including clean technology, creative office uses, and other emerging industries that create new jobs.

3.14.11 Promote the development of hybrid industrial uses in the Downtown Plan Area and in portions of the Boyle Heights Community Plan Area adjacent to the Los Angeles River that provide an opportunity for local employees to live and work in close proximity and thereby further the sustainability goals of the City, while safeguarding space for employment, including light industrial, commercial, manufacturing, and creative office uses.

ii. General Plan Land Use and Zoning Designations

While the EIR analyzed a mix of Hybrid Industrial and Community Center land use designations, with corresponding zoning districts, a policy preference for designating the entirety of the subject area as Hybrid Industrial has emerged. This designation would allow for the continuation of long-standing light industrial uses within the area, while allowing for the incorporation of housing uses, both through the adaptive reuse of existing buildings, and through new construction development projects. In addition, the following amendments to zoning correspondence with the Hybrid Industrial land use designation should also be introduced:

The Industrial Mixed-use 6 (IX6) zoning Use District should be introduced to correspond to the Hybrid Industrial land use designation. The IX6 Use District allows for a broad range of light industrial, commercial, and residential activities, consistent with the light industrial zoning that would otherwise be established under the CPC's recommended Community Plan. The IX6 Use District also allows for housing uses both through the adaptive reuse of existing buildings, and through new construction. New housing structures would be required to provide 0.5 FAR toward either a Designated Production Space (i.e. light manufacturing, artisanal manufacturing, or office uses), or through the re-homing of a Legacy Small Business.

The LM3, LM4, LM6, and LM7 Form Districts should be introduced to correspond to the Hybrid Industrial land use designation. These Form Districts allow building scales that are compatible with potential future housing development within the subject area, including Base FARs of 1.5, and Maximum Bonus FARs of 3.0 and 4.0. LM3, would abut Clarence Street, a narrow local street across from a low-scale residential uses, and would include a maximum four-story height limit. LM4 and LM6 allow for 3.0 and 4.0 Bonus FAR respectively, and are widely used along many of Boyle Height's corridors. LM7 is a new Form District that includes "bulk plane" requirements that are intended to address how new buildings relate to the adjacent Sixth Street bridge and park.

The 4 and 8 Density Districts should be introduced to correspond to the Hybrid Industrial land use designation. These districts allow for residential densities that are compatible with future housing development within the subject area, at one unit per 400 square feet of lot area, and 800 square feet per lot area, respectively.

Recommendation

In whole, the following land use and zoning is recommended should the City Council elect to introduce housing uses:

Industrial Mixed-use 6 (IX6) District

Establish the IX6 Use District as a corresponding zone in the Hybrid Industrial land use designation, as shown in Appendix I - IX6 Use District I of this memo.

General Plan Land Use: Hybrid Industrial

Properties that were initially proposed to be designated Light Industrial between Aliso Street, Myers Street, Mission Road and between Willow St, 6th Street, Union Pacific right-of-way, and Mission Road:

Form District: LM4 (3:1 Max FAR)
Frontage District: GW1
Development Standards District: 4
Use District: IX6
Density District: 4

Properties that were initially proposed to be designated Light Industrial between Myers Street, Willow St, 6th Street, Union Pacific right-of-way, and Mission Road:

Form District: LM4 (3:1 Max FAR)
Frontage District: GW1
Development Standards District: 4
Use District: IX6
Density District: 8

Properties that were initially proposed to be designated Light Industrial between Whittier Boulevard, Jesse Street, Union Pacific right-of-way, and Mission Road:

Form District: LM6 (4:1 Max FAR)
Frontage District: GW1
Development Standards District: 4
Use District: IX6
Density District: 4

Properties that were initially proposed to be designated Light Industrial between 3rd Street, 6th Street, and Mission Road, and Clarence Street (excluding properties fronting Clarence Street and properties owned by the City of Los Angeles on Artemus Street between Mission Road and Anderson Street):

Form District: LM4 (3:1 Max FAR)
Frontage District: G2
Development Standards District: 4
Use District: IX6

Density District: 8

Properties that were initially proposed to be designated Light Industrial fronting Clarence Street between 3rd Street and Inez Streets:

Form District: LM3 (2.5:1 Max FAR)
Frontage District: G2
Development Standards District: 4
Use District: IX6
Density District: 8

Properties that were initially proposed to be designated Light Industrial between Jesse Street and 7th Street, 101 Freeway, and Myers Street, and three parcels located at the southeast corner of the intersection of 6th Street and Anderson Street:

Form District: LM6 (4:1 Max FAR)
Frontage District: G2
Development Standards District: 4
Use District: IX6
Density District: 4

Properties that were initially proposed to be designated Light Industrial between 6th Street and Jesse Street, 101 Freeway, and Mission Road (excluding properties fronting Whittier Boulevard that are owned by the City of Los Angeles):

Form District: LM6 (4:1 Max FAR)
Frontage District: GW1
Development Standards District: 4
Use District: IX6
Density District: 4

General Plan Land Use: Community Center

Properties that were initially proposed to be designated Light Industrial between Azusa Street, 3rd Street, Mission Road, and Anderson Street:

Form District: LM6 (4:1 Max FAR)
Frontage District: SH3
Development Standards District: 4
Use District: CX2
Density District: 4

General Plan Land Use: Public Facilities

Properties that were initially proposed to be designated Light Industrial that front Whittier Boulevard and owned by the City of Los Angeles between the 101 Freeway and Los Angeles River:

PLUM Committee

CF 23-0861

Page 23

Form District: LM6 (4:1 Max FAR)

Frontage District: WH1

Development Standards District: 4

Use District: P2

Density District: FA

Properties that were initially proposed to be designated Light Industrial between Union Pacific right-of-way, Mission Road, and Myers Street, and City of Los Angeles owned properties along Artemus Street between Mission Road and Anderson Street.

Form District: LM4 (3:1 Max FAR)

Frontage District: WH1

Development Standards District: 4

Use District: P2

Density District: FA

Map II.A.ii-1: General Plan Land Use Designations

Proposed Plan with Light Industrial



Modified Plan with Hybrid Industrial



A.1–A.2 - Technical Modifications

In addition, to support the changes listed above the following additional technical modifications are recommended:

A.1 Technical Modification: Framework Amendments

Amend the Framework Amendments (**Exhibit C5**) to introduce “4” and “8” Densities corresponding to the Hybrid Industrial Table 3-9a and amend the description of Hybrid Industrial to read “Hybrid Industrial areas preserve productive activity and prioritize employment uses, but may accommodate live/work uses or limited residential uses. The building form ranges from Low-Rise to Mid-Rise. Uses include light industrial, commercial, and office, with selective live/work uses. The residential density ranges from 1 unit per 400 square feet of lot area to being generally is limited by floor area.”

A.2 LAMC Chapter 1A, Article 5 (Use), Sec. 5C.4. (Special Use Programs)

Add Sec. 5C.4.6. Legacy Small Business Special Use Program into Sec. 5C.4. of Article 5 (Use) of Chapter 1A of the LAMC to read as follows:

Sec. 5C.4.6. Legacy Small Business Special Use Program

A. Intent

To create long-lasting opportunities for existing commercial tenants to remain in the communities they serve.

B. Applicability

1. Applies when a legacy small business is utilized to meet the In Conjunction With requirements of a Use District, or
2. When another provision of this Zoning Code requires compliance with this Section.

C. Standards

1. The legacy small business shall have been within continuous operations within a 2 mile radius of the project site within the City for at least 10 years with no break in its operations exceeding two years, and meet at least two of the following four standards:
 - a. Has no more than 100 employees/shareholders;
 - b. The business includes employees that can serve multi-lingual members of the community;
 - c. Accepts government issued assistance such as Electronics Benefits Transfer (EBT);
 - d. Pays employees wages equivalent to or greater than those specified in Sec. 10.37.2 (Payment of Minimum Compensation to Employees) of Article 11 (Living Wage) of the Los Angeles Administrative Code.
2. The floor area required to be dedicated to the legacy small business shall be occupied by a legacy small business for at least 10 years, or longer if stipulated in the lease agreement.
 - a. For the purposes of this provision, the time in which the minimum required FAR dedicated to the legacy small business space is vacant does not count towards the required minimum.

- b. After the 10 year minimum requirement has been satisfied, any use allowed in the applied Use District (Part 5B) is permitted.

D. Measurement

1. The minimum floor area ratio (FAR) required to be dedicated to a legacy small business is established under the In Conjunction With requirement of the applicable Use District per Sec. 5C.3.13. (In Conjunction With), where applicable.
2. Distance shall be measured pursuant to Sec. 14.1.3.A. (Distance)

E. Records & Agreements

1. Lease

- a. A minimum 10-year lease with a legacy small business, with a 5 year renewal option shall be required prior to a City Planning administrative sign-off or case condition clearance pursuant to Sec. 13B.3.1. (Administrative Review).
- b. This requirement does not mean that the legacy small business is required to complete the term of the lease. If the lease is not completed for the entirety of the 10-year term, the property owner or their representative shall find a new legacy small business to complete the 10-year term.
- c. Should the legacy small business decide to terminate the lease, the owner shall have up to 1 year from the date of the lease termination to establish a lease with a new legacy small business.

2. Covenant

- a. A covenant acceptable to the Department of City Planning must be recorded with the Los Angeles County Recorder, guaranteeing that the applicant, tenant, or property owner will dedicate floor area within the development for legacy small business for the periods outlined in this Section, and will submit annual reporting to the Department of City Planning in a manner consistent with Sec. 9.3.4.E.4. (Annual Reporting).

3. Annual Reporting

- Projects receiving a floor area exemption pursuant to this Section shall demonstrate compliance by submitting an annual report to the Department of City Planning.

- a. Annual Legacy Small Business Report
The Annual Legacy Small Business Report shall be provided by the property owner that delineates the following:
 - i. Occupancy status of the development.
 - ii. Occupancy status of the Legacy Small Business.
 - iii. Evidence as to compliance with any requirements of this Section
- b. Non-Compliance
Non-compliance with the requirements of this Section shall result in either renewal of the term of the lease or legal action taken against the owner to comply with the contract.
- c. Review
The Department of City Planning shall review the Annual Legacy Small Business Report pursuant to Sec. 13B.3.1. (Administrative Review).

iii. Inclusionary Housing

Council District 14 requested that City Planning present an economic analysis to determine the extent to which affordable housing units could be required as part of any prospective housing development within the subject industrial district, were the City to allow housing uses. The analysis is intended to support any further consideration by the City as to whether the subject area would remain zoned for light industrial uses, or to allow future housing development. An initial analysis has been completed that considered typical podium-style (seven stories) residential development within the area.

The initial economic analysis found that under a mixed-use project, the maximum set-aside percentages and AMI levels for an inclusionary housing obligation are: 13% Acutely Low, 15% Extremely Low, 17% Very Low, and 22% Low. Larger projects would be the most feasible and requiring additional affordable units beyond the aforementioned recommended percentages yield projects infeasible. As such, a 60% mandatory inclusionary housing requirement as had been requested by Council District 14 at the April 20, 2023 CPC meeting, would not be feasible.

Recommendation

A.3–A.4 - Technical Modifications to Chapter 1A of the LAMC

The following technical modifications to Chapter 1A of the LAMC are suggested should the City Council elect to introduce housing uses with an inclusionary housing obligation.

A.3 LAMC Chapter 1A, Article 5 (Use), Sec. 5C.4.5. (Inclusionary Housing Program)

Modify Section 5C.4.5.C.1. (Inclusionary Program Set Designations) of Article 5 (Use) of Chapter 1A of the LAMC to create a new affordability requirement set and incorporate the Acutely Low Income bracket into the affordability requirements, as shown below.

Sec. 5C.4.5.C. (Inclusionary Standards)

1. Inclusionary Program Set Designations

Unless otherwise established in an applied Community Plan Implementation Overlay, an inclusionary housing project shall provide the minimum percentage of on-site restricted affordable units required by the designated affordability requirement set as established below.

Table II.A.iii-1 Inclusionary Housing Affordability Requirements

| AFFORDABILITY REQUIREMENT SETS | | | | | |
|--------------------------------|----------------------------------|----------------------|-----------------|--------------|-----------------|
| Set | Affordability Requirements | | | | |
| | <u>DEEPLY ACUTELY LOW INCOME</u> | EXTREMELY LOW INCOME | VERY LOW INCOME | LOWER INCOME | MODERATE INCOME |
| A | 8% | 8% | 10% | 12% | 16% |
| B | 12% | 13% | 15% | 17% | 28% |
| C | 80% | 80% | 80% | 80% | 80% |
| <u>D</u> | <u>13%</u> | <u>15%</u> | <u>17%</u> | <u>22%</u> | <u>n/a</u> |

* "n/a" means not applicable

a. Calculating Required Units

An inclusionary housing project shall provide at minimum the percentage of required restricted affordable units specified in at least one of the applicable income ranges specified in the applicable Affordability Requirement Set. The minimum percentage of required restricted affordable units shall be calculated based on the total number of dwelling units in the inclusionary housing project. Any number resulting in a fraction shall be rounded up to the next whole number, and not as specified in Sec. 6C.1.2. (Lot Area Per Household Dwelling Unit) or Sec. 6C.1.3. (Lot Area Per Efficiency Dwelling Unit). Restricted affordable units provided pursuant to this program may also count towards the affordable housing incentive programs established in Sec. 9.2.1. (Density Bonus) or Sec.9.3.2. (Local Affordable Housing Incentive Program).

b. For-Sale Units

Restricted affordable units which are offered on a for-sale bases shall be subject to an applicant agreement with the Los Angeles Housing Department that ensures that a for-sale unit that qualified the applicant for the affordable housing program and meets the following conditions:

- i. The unit is initially occupied by a person or family of moderate income, low income, very low income, or extremely low income, as required, and it is offered at an affordable housing cost, as that cost is defined in Section 50052.5 of the California Health and Safety Code and is subject to an equity sharing agreement.
- ii. The unit is purchased by a qualified nonprofit housing corporation pursuant to a recorded contract that satisfies all of the requirements specified in PLUM Committee CF 22-0617 Page 26 (10) of Subdivision (a) of Section 402.1 of the Revenue and Taxation Code and that includes all of the following:
 - a) A repurchase option that requires a subsequent purchaser of the property that desires to resell or convey the property to offer the qualified nonprofit housing corporation the right to repurchase the property prior to selling or conveying that property to any other purchaser.
 - b) An equity sharing agreement, as specified in Subdivision 6 (Equity Sharing Agreement) of Subsection E. (Records & Agreements) below.
 - c) Affordability restrictions on the sale and conveyance of the property that ensure that the property will be preserved for lower income housing for at least 45 years for owner-occupied housing units and will be sold or resold only to persons or families of moderate income, low income, very low income, or extremely low income, as defined in Section 50052.5 of the California Health and Safety Code.

A.4 LAMC Chapter 1A, Article 1 (Introductory Provisions), Zoning Code Map (Inclusionary Program Set Designations)

Modify the Zoning Code Maps (**Exhibit E2**) to include a new Inclusionary Housing Program Zoning Code Map to designate identified parcels, those to be designated within the Hybrid Industrial land use designation, and zoned within the IX6 Use District, within

the Boyle Heights Community Plan with mandatory inclusionary housing for rental housing with affordability requirement set D.

iv. Form District Modifications

Should housing uses be introduced into the subject industrial district, Council District 14 requested that City Planning present modifications to assigned Form Districts in this area that would be more consistent with the revised Zoning Use Districts (i.e. allowing housing uses), complement the Sixth Street Viaduct, Sixth Street PARC Project and Los Angeles River, and minimize the impact of any future development on existing adjacent housing uses.

Modify existing Form Districts LM4 and LM6

Areas adjacent to the Los Angeles River within the subject industrial district are assigned a Frontage District Greenway 1 (GW1), which provides standards that seek to address how new development interfaces with the adjacent river corridor. As housing uses are being introduced to this area, it has been necessary to recommend the LM4 and LM5 Form Districts here (see section i. above), in lieu of the originally proposed low-scale VM1 Form District. The LM4 and LM5 Form Districts are also used elsewhere in Boyle Heights, and do not have the necessary setback requirements needed to work in concert with the Greenway 1 Frontage District, which would require that buildings be setback 15 feet from the river-abutting property line.

Modifications to the existing Form Districts LM4 and LM6 are recommended to maintain the intent of Frontage District GW1. The modifications would include removing the existing rear building setback standard of 10 feet and adding a building setback of 15 feet along a “special lot line” (i.e. the river-abutting property line). This would ensure that any future development along the Los Angeles River would continue to the intent of creating open area along the side of properties fronting the Los Angeles River. To maintain the original intent of the existing rear building setback standard of 10 feet that would be removed from Form Districts LM4 and LM6, a new upper-story bulk standard would be introduced to regulate transitional height if an adjoining district has a maximum allowed height of 36 feet or 3 stories.

Three additional technical modifications to Form Districts LM4 and LM6 would provide consistency and clarity. The first modification would establish a lot area (min) of 1,000 square feet and lot width (min) of 20 feet and the second modification would increase the lot amenity space (min) from 15% to 20%, so as to both be consistent with the same standards as found in similar Form Districts. The third modification would simplify the height standard by removing the base height in feet (max) and bonus height in feet (max) fields currently both listed as “n/a” and replacing them with a single height (max) field listed as “none”.

Introduce new Form District LM7

Together the Sixth Street Viaduct and Sixth Street PARC Project create a unique sense of place and serve as valuable public and open space community assets. Should housing uses be introduced into the subject industrial district, in-lieu of originally planned low-scale light industrial uses, it would be important to ensure that development not visually overcrowd the bridge and park and that natural light can penetrate into public areas, in particular, the public park that is to be located beneath the bridge. The creation of a new Form District LM7, would introduce a bulk plane standard that would apply to “special lot lines” (i.e. property lines abutting the bridge and park). The standard regulates bulk by requiring that above an origin height of 36 feet or 3 stories, the height of new development cannot exceed past an angled plane of 45 degrees. In effect, the height of new buildings would angle away from the bridge and park in a uniform manner, preserving visibility to and from the bridge, and allowing for the penetration of natural light under the bridge, as demonstrated in the model below. The new Form District LM7 would apply only in this unique area.

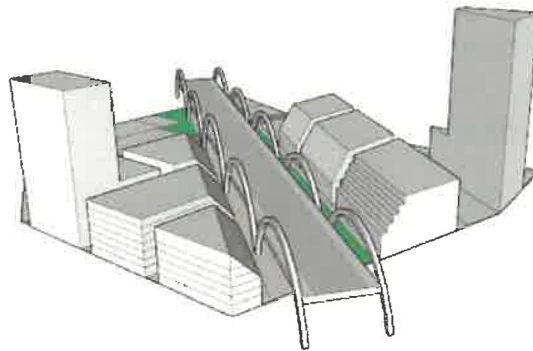

Figure II.A.iv-1: Sixth Street Bulk Plane (Note: This model for illustrative purposes only and does not represent real or proposed projects.)

Recommendation

In the event that the City Council determines housing uses should be introduced to this area, it is recommended that the following Form District modifications are implemented.

A.5–A.8 - Technical Modifications to Chapter 1A of the LAMC

The following technical modifications to Chapter 1A of the LAMC are suggested should the City Council elect to introduce housing uses and the recommended Form District modifications.

A.5 LAMC Chapter 1A, Article 2 (Form Districts), Sec. 2B.9.4. (Low-Rise Medium 4 (LM4))

Modify the existing Lot Size, Coverage, Amenity, and FAR & Height standards, and introduce new Upper-Story Bulk standards in Section 2B.9.4. of Article 2 (Form Districts) of Chapter 1A of the LAMC as demonstrated by the following original and modified versions of Form District LM4:

Original Form District LM4

FORM - Low-Rise Medium Form Districts

SEC 2B.9.4 LOW-RISE MEDIUM 4 (LM4)

A. Lot Parameters

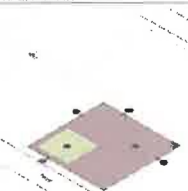

B. Bulk and Mass

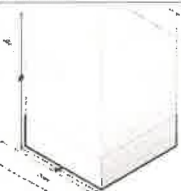

| Parameter | Value | Parameter | Value |
|---------------------------------|--------|--------------------------|-------|
| Lot area (sq ft) | 10,000 | Max height (ft) | 35 |
| Lot width (ft) | 100 | Max height w/ roof (ft) | 35 |
| Building coverage (max) | 100% | Max height to floor (ft) | 35 |
| Building setbacks | | Max height to roof (ft) | 35 |
| Front street (ft) | 0 | Building setback (ft) | 0 |
| Side (ft) | 0 | | |
| Rear (ft) | 0 | | |
| Alley (ft) | 0 | | |
| Special: All level | 0 | | |
| Lot amenity space (max) | 10% | | |
| Residential amenity space (max) | 10% | | |

BOYLE HEIGHTS - PROPOSED DRAFT - 03/17/2023 City of Los Angeles Zoning Code | 2-58

Modified Form District LM4

FORM - Low-Rise Medium Form Districts

SEC 2B.9.4 LOW-RISE MEDIUM 4 (LM4)

A. Lot Parameters



B. Bulk and Mass



| Parameter | Value | Parameter | Value |
|---------------------------------|-------------|--------------------------|-------|
| Lot area (sq ft) | 1,000 sq ft | Max height (ft) | 15 |
| Lot width (sq ft) | 20 | Max height w/ roof (ft) | 15 |
| Building coverage (max) | 100% | Max height to floor (ft) | 15 |
| Building setbacks | | Max height to roof (ft) | 15 |
| Front street (ft) | 0 | Building setback (ft) | 0 |
| Side street (ft) | 0 | | |
| Side (ft) | 0 | | |
| Rear (ft) | 0 | | |
| Alley (ft) | 0 | | |
| Special: All level | 0 | | |
| Lot amenity space (max) | 20% | | |
| Residential amenity space (max) | 10% | | |

BOYLE HEIGHTS - POST-CPC DRAFT - 03/17/2023

A.6 LAMC Chapter 1A, Article 2 (Form Districts), Sec. 2B.9.6. (Low-Rise Medium 6 (LM6))

Modify the existing Lot Size, Coverage, Amenity, and FAR & Height standards, and introduce new Upper-Story Bulk standards in Section 2B.9.6. of Article 2 (Form Districts) of Chapter 1A of the LAMC as demonstrated by the following original and modified versions of Form District LM6:

Original Form District LM6

FORM
Low-Rise Medium Form Districts

SEC 2B.9.6 LOW-RISE MEDIUM 6 (LM6)

A. Lot Parameters

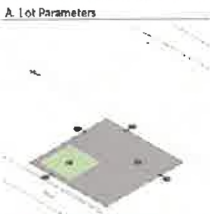

B. Bulk and Mass

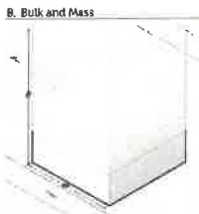

| Parameter | Value | Parameter | Value |
|-----------------------------------|-------|----------------------------|-------|
| Lot area (sq ft) | n/a | Base FAR (sq ft) | 1.5 |
| Lot width (ft) | n/a | Base height in feet | 35 |
| Building coverage (sq ft) | 100% | Base lot depth | 40 |
| Front setback (ft) | 5 | Base height in feet (max) | n/a |
| Side setback (ft) | 5 | Building width (ft) | 40 |
| Rear setback (ft) | 5 | Building depth (ft) | 40 |
| Alley setback (ft) | 0 | Building height (ft) | 35 |
| Special ALP (ft) | 0 | Building height (ft) (max) | n/a |
| Lot amenity space (sq ft) | 10% | Building height (ft) (min) | 10 |
| Residential amenity space (sq ft) | 10% | | |

Modified Form District LM6

FORM
Low-Rise Medium Form Districts

SEC 2B.9.6 LOW-RISE MEDIUM 6 (LM6)

A. Lot Parameters



B. Bulk and Mass

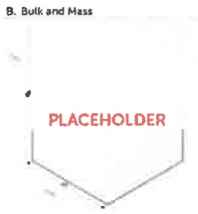



| Parameter | Value | Parameter | Value |
|-----------------------------------|----------|----------------------------|-------|
| Lot area (sq ft) | 1,000 sf | Base FAR (sq ft) | 1.5 |
| Lot width (ft) | 20 | Base height in feet | n/a |
| Building coverage (sq ft) | 100% | Base lot depth | 40 |
| Front setback (ft) | 0 | Base height in feet (max) | n/a |
| Side setback (ft) | 0 | Building width (ft) | 40 |
| Rear setback (ft) | 0 | Building depth (ft) | 40 |
| Alley setback (ft) | 0 | Building height (ft) | 35 |
| Special ALP (ft) | 0 | Building height (ft) (max) | n/a |
| Lot amenity space (sq ft) | 20% | Building height (ft) (min) | 10 |
| Residential amenity space (sq ft) | 10% | | |

A.7 LAMC Chapter 1A, Article 2 (Form Districts), Sec. 2B.9. (Low-Rise Medium Form Districts)

Introduce new Section 2B.9.7. Low-Rise Medium 7 (LM7) of Article 2 (Form Districts) of Chapter 1A of the LAMC to read as follows:

FORM - Low-Rise Medium Form Districts -

SEC. 2B.9.7. LOW-RISE MEDIUM 7 (LM7)

| | | | | | | | | | | | | | | | | | | | | | | | | | | | | | | | | | | | | | | | | | | | | | | | | | | | | | |
|--|----------------|----------|-----------------|-----|-------------------------|------|----------------------|---|-------------------|---|------------|---|------------|---|-------------|---|--------------------|-----|-------------------------|-----|---------------------------------|-----|--|-----------|-----|--------------|------|-----------------|-----|------------|--|---------------------|---------|---------------|----------------|-------|-----|---------------------|--|---|----------------|----------------------|-----|-------------------------|-----|-------------------------|-----|-------------------------|-----|----------------------|------|----------------------|-----|
| <p>A. Lot Parameters</p>  <p>1. LOT SIZE (Sec. 2B.4)</p> <table border="1"> <tr><td>Lot area (min)</td><td>1,000 sf</td></tr> <tr><td>Lot width (min)</td><td>20'</td></tr> </table> <p>2. COVERAGE (Sec. 2B.3)</p> <table border="1"> <tr><td>Building coverage (max)</td><td>100%</td></tr> </table> <p>Building setbacks</p> <table border="1"> <tr><td>Primary street (min)</td><td>0</td></tr> <tr><td>Side street (min)</td><td>0</td></tr> <tr><td>Side (min)</td><td>0</td></tr> <tr><td>Rear (min)</td><td>0</td></tr> <tr><td>Alley (min)</td><td>0</td></tr> <tr><td>Special: All (min)</td><td>15'</td></tr> </table> <p>3. AMENITY (Sec. 2B.5)</p> <table border="1"> <tr><td>Lot amenity space (min)</td><td>20%</td></tr> <tr><td>Residential amenity space (min)</td><td>10%</td></tr> </table> | Lot area (min) | 1,000 sf | Lot width (min) | 20' | Building coverage (max) | 100% | Primary street (min) | 0 | Side street (min) | 0 | Side (min) | 0 | Rear (min) | 0 | Alley (min) | 0 | Special: All (min) | 15' | Lot amenity space (min) | 20% | Residential amenity space (min) | 10% | <p>B. Bulk and Mass</p>  <p>1. FAR & HEIGHT (Sec. 2B.4)</p> <table border="1"> <tr><td>FAR (max)</td><td>1.5</td></tr> <tr><td>Height (max)</td><td>none</td></tr> <tr><td>Bonus FAR (max)</td><td>4.0</td></tr> </table> <p>2. UPPER-STORY (Sec. 2B.4)</p> <table border="1"> <tr><td>Bulk plane</td><td></td></tr> <tr><td>Applicable lot line</td><td>Special</td></tr> <tr><td>Origin height</td><td>36 / 3 stories</td></tr> <tr><td>Angle</td><td>45°</td></tr> <tr><td>Transitional height</td><td></td></tr> <tr><td>Applicability: max allowed height of adjoining district</td><td>36 / 3 stories</td></tr> <tr><td>Street setback (min)</td><td>10'</td></tr> <tr><td>Rear/side setback (min)</td><td>10'</td></tr> <tr><td>3rd story setback (min)</td><td>20'</td></tr> <tr><td>6th story setback (min)</td><td>30'</td></tr> </table> <p>3. BUILDING MASS (Sec. 2B.4)</p> <table border="1"> <tr><td>Building width (max)</td><td>140'</td></tr> <tr><td>Building break (min)</td><td>15'</td></tr> </table> | FAR (max) | 1.5 | Height (max) | none | Bonus FAR (max) | 4.0 | Bulk plane | | Applicable lot line | Special | Origin height | 36 / 3 stories | Angle | 45° | Transitional height | | Applicability: max allowed height of adjoining district | 36 / 3 stories | Street setback (min) | 10' | Rear/side setback (min) | 10' | 3rd story setback (min) | 20' | 6th story setback (min) | 30' | Building width (max) | 140' | Building break (min) | 15' |
| Lot area (min) | 1,000 sf | | | | | | | | | | | | | | | | | | | | | | | | | | | | | | | | | | | | | | | | | | | | | | | | | | | | |
| Lot width (min) | 20' | | | | | | | | | | | | | | | | | | | | | | | | | | | | | | | | | | | | | | | | | | | | | | | | | | | | |
| Building coverage (max) | 100% | | | | | | | | | | | | | | | | | | | | | | | | | | | | | | | | | | | | | | | | | | | | | | | | | | | | |
| Primary street (min) | 0 | | | | | | | | | | | | | | | | | | | | | | | | | | | | | | | | | | | | | | | | | | | | | | | | | | | | |
| Side street (min) | 0 | | | | | | | | | | | | | | | | | | | | | | | | | | | | | | | | | | | | | | | | | | | | | | | | | | | | |
| Side (min) | 0 | | | | | | | | | | | | | | | | | | | | | | | | | | | | | | | | | | | | | | | | | | | | | | | | | | | | |
| Rear (min) | 0 | | | | | | | | | | | | | | | | | | | | | | | | | | | | | | | | | | | | | | | | | | | | | | | | | | | | |
| Alley (min) | 0 | | | | | | | | | | | | | | | | | | | | | | | | | | | | | | | | | | | | | | | | | | | | | | | | | | | | |
| Special: All (min) | 15' | | | | | | | | | | | | | | | | | | | | | | | | | | | | | | | | | | | | | | | | | | | | | | | | | | | | |
| Lot amenity space (min) | 20% | | | | | | | | | | | | | | | | | | | | | | | | | | | | | | | | | | | | | | | | | | | | | | | | | | | | |
| Residential amenity space (min) | 10% | | | | | | | | | | | | | | | | | | | | | | | | | | | | | | | | | | | | | | | | | | | | | | | | | | | | |
| FAR (max) | 1.5 | | | | | | | | | | | | | | | | | | | | | | | | | | | | | | | | | | | | | | | | | | | | | | | | | | | | |
| Height (max) | none | | | | | | | | | | | | | | | | | | | | | | | | | | | | | | | | | | | | | | | | | | | | | | | | | | | | |
| Bonus FAR (max) | 4.0 | | | | | | | | | | | | | | | | | | | | | | | | | | | | | | | | | | | | | | | | | | | | | | | | | | | | |
| Bulk plane | | | | | | | | | | | | | | | | | | | | | | | | | | | | | | | | | | | | | | | | | | | | | | | | | | | | | |
| Applicable lot line | Special | | | | | | | | | | | | | | | | | | | | | | | | | | | | | | | | | | | | | | | | | | | | | | | | | | | | |
| Origin height | 36 / 3 stories | | | | | | | | | | | | | | | | | | | | | | | | | | | | | | | | | | | | | | | | | | | | | | | | | | | | |
| Angle | 45° | | | | | | | | | | | | | | | | | | | | | | | | | | | | | | | | | | | | | | | | | | | | | | | | | | | | |
| Transitional height | | | | | | | | | | | | | | | | | | | | | | | | | | | | | | | | | | | | | | | | | | | | | | | | | | | | | |
| Applicability: max allowed height of adjoining district | 36 / 3 stories | | | | | | | | | | | | | | | | | | | | | | | | | | | | | | | | | | | | | | | | | | | | | | | | | | | | |
| Street setback (min) | 10' | | | | | | | | | | | | | | | | | | | | | | | | | | | | | | | | | | | | | | | | | | | | | | | | | | | | |
| Rear/side setback (min) | 10' | | | | | | | | | | | | | | | | | | | | | | | | | | | | | | | | | | | | | | | | | | | | | | | | | | | | |
| 3rd story setback (min) | 20' | | | | | | | | | | | | | | | | | | | | | | | | | | | | | | | | | | | | | | | | | | | | | | | | | | | | |
| 6th story setback (min) | 30' | | | | | | | | | | | | | | | | | | | | | | | | | | | | | | | | | | | | | | | | | | | | | | | | | | | | |
| Building width (max) | 140' | | | | | | | | | | | | | | | | | | | | | | | | | | | | | | | | | | | | | | | | | | | | | | | | | | | | |
| Building break (min) | 15' | | | | | | | | | | | | | | | | | | | | | | | | | | | | | | | | | | | | | | | | | | | | | | | | | | | | |

BOYLE HEIGHTS - POST-CPC DRAFT - FALL 2023 City of Los Angeles Zoning Code 2-23

A.8 Technical Modification: Zoning Code Maps

Modify the Special Lot Line Map in Zoning Code Maps (**Exhibit E2**) to designate special lot lines identified along the side of properties adjacent to the Sixth Street PARC Project.

v. Sixth Street PARC Project Parcels

Council District 14 requested that City Planning identify all parcels associated with the Sixth Street PARC Project owned by the City of Los Angeles and modify their General Plan designation from Light Industrial to Public Facilities. This change would ensure that the existing use of a park and maintenance facilities on these parcels is consistent with the General Plan designation of Public Facilities.

Recommendation

It is recommended that the City Council accept the recommendation to designate City of Los Angeles owned parcels associated with the Sixth Street PARC Project as Public Facilities.

A.9–A.10 - Technical Modifications

The following technical modifications are suggested should the City Council elect to accept the recommended General Plan designation change.

A.9 Technical Modification: General Plan Land Use Map

Modify the General Plan Land Use Map (**Exhibit C3**) to include Form District LM6 corresponding to Public Facilities in the Correspondence Table.

A.10 Technical Modification: Boyle Heights Community Plan Implementation Overlay (CPIO) District

Add the identified parcels owned by the City of Los Angeles to the Boyle Heights Community Plan Implementation Overlay (CPIO) District (**Exhibit D1**) Subarea D – Public Lands.

vi. New CPIO Subarea for Non-residential Public Benefit Incentives

The designation of a Hybrid Industrial land use designation, in concert with the Use District IX6, and Form Districts LM3, LM4, LM6, and LM7 will allow for a range of moderately scaled non-residential, employment-focused uses to be developed in the future. This presents a need to adapt the Boyle Heights Community Benefits Program to include FAR incentives for non-residential projects that include specific community benefits. Using the Community Facilities enumerated under Article 9 of the newly established zoning code, non-residential projects may exceed the Base FAR of 1.5, up to 3.0 FAR or 4.0 FAR (depending on Form District designation), through a ministerial process, when the following Community Facilities are provided:

- Legacy Small Businesses: Re-homing an existing business that meets three of the following criteria: exists within two-miles of the project location, has fewer than 100 FTE employees, has been in business for at least 20 years, provides multi-lingual products or services, or accepts EBT.
- Daycare Facility: a licensed childcare facility
- Full-Service Grocery Store: a grocery store that is at least 10,000 square feet, accepts EBT, provides fresh produce and perishable items.
- Health Center: a Federally Qualified Health clinic that accepts MediCal and MediCare, and offers a sliding scale.

- Employment Center: a non-residential project that dedicates at least 50% of its floor area toward targeted non-residential uses.
- School and Library: Any LAUSD or LALD public school or library.
- Social Service: Non-profit services that include employment services, job training, business incubation, youth development, educational services, medical care, mental health care, substance abuse treatment, or food aid (social service centers).
- Civic Facility: cultural centers, museums, police stations, fire stations, community centers, indoor recreation, or other public facilities

Recommendation

It is recommended that the City Council accept the recommendation to adapt the Boyle Heights Community Benefits Program to include FAR incentives for non-residential projects that include specific community benefits.

A.11–A.13 - Technical Modifications

The following technical modifications are suggested should the City Council elect to modify the Boyle Heights Community Benefits Program to include FAR incentives for non-residential projects.

A.11 Technical Modification: Boyle Heights Community Plan Implementation Overlay (CPIO) District, Community Facilities Incentives

Add section II – 5. FAR Incentives for Non-residential Projects into Chapter II – Community Benefits Program Subarea of the Boyle Heights Community Plan Implementation Overlay (CPIO) District (**Exhibit D1**) to read as follows:

II – 5. FAR Incentives for Non-residential Projects. A non-residential project that meets the requirements outlined in LAMC Ch. 1A 9.3.4. shall be eligible for the maximum bonus FAR in the Form District.

1. For sites located in Subarea A.2 seeking to utilize the Community Facilities incentive must dedicate a minimum of 5,000 square feet to any of the eligible uses provided for within LAMC Chapter 1A Section 9.3.4.C.
2. For sites located in Subarea A.2 seeking to utilize the Employment Incentive Area, projects in which a minimum of 50% of the total Floor Area, inclusive of any bonus floor area, contains non-residential uses, excluding uses in the Eating and Drinking Establishments, Personal Services, and Retail Sales use groups, may obtain additional floor area above the base FAR and up to 4.0:1 FAR pursuant to the Employment Incentive Area, LAMC Chapter 1A Section 9.3.4.C.4. e.

- a. A Housing Development must fully utilize the Local Affordable Housing Incentive Program pursuant to LAMC Chapter 1A 9.3.2 before obtaining Floor Area through this incentive.

A.12 Technical Modification: Boyle Heights Community Plan Implementation Overlay (CPIO) District Subareas

Modify the Boyle Heights Community Plan Implementation Overlay (CPIO) District (**Exhibit D1**), Chapter II - Community Benefits Program Subarea to establish new Subarea A.1 and Subarea A.2 maps. Subarea A.1 would include the originally selected parcels for Subarea A, as well as the identified parcels where Use District IX6 is applied (pursuant to Section ii of this memo). Subarea A.2 would include the identified parcels where Use District IX6 is applied (pursuant to Section ii of this memo).

A.13 LAMC Chapter 1A, Article 9 (Public Benefit Systems), Sec. 9.3.4. (Community Facilities)

Add Sec. 9.3.4.C.9. Legacy Small Business Incentive Area to the Community Facility Options in Sec. 9.3.4.C. of Article 9 (Public Benefit Systems) of Chapter 1A of the LAMC to read as follows:

9. Legacy Small Business Incentive Area

A project within a Legacy Small Business Incentive Area in an applicable CPIO or Specific Plan may obtain additional floor area, subject to the following standards:

- a. The legacy small business shall meet at least three of the following five standards:
 - i. Has been in continuous operation within a 2 mile radius of the project site within the City for at least 10 years with no break in its operations exceeding two years;
 - ii. Has no more than 100 employees/shareholders;
 - iii. The business includes employees that can serve multi-lingual members of the community;
 - iv. Accepts government issued assistance such as Electronics Benefits Transfer (EBT);

- v. Pays employees wages equivalent to or greater than those specified in Sec. 10.37.2 (Payment of Minimum Compensation to Employees) of Article 11 (Living Wage) of the Los Angeles Administrative Code.
- b. The floor area used as a legacy small business shall be used for such purposes for at least 10 years, or longer if stipulated in the lease agreement.
 - i. For the purposes of this provision, the time in which the minimum required FAR dedicated to the legacy small business space is vacant does not count towards the required minimum.
 - ii. After the 10 year minimum requirement has been satisfied, any use allowed in the applied Use District (Part 5B) is permitted.
- c. The floor area devoted to a legacy small business shall be located on-site.
- d. Lease
 - i. A minimum 10-year lease with a legacy small business, with a 5 year renewal option shall be required prior to a City Planning administrative sign-off or case condition clearance pursuant to Sec. 13B.3.1. (Administrative Review).
 - ii. This requirement does not mean that the legacy small business is required to complete the term of the lease. If the lease is not completed for the entirety of the 10-year term, the property owner or their representative shall find a new legacy small business to complete the 10-year term.
 - iii. Should the legacy small business decide to terminate the lease, the owner shall have up to 1 year from the date of the lease termination to establish a lease with a new legacy small business.

B. Legacy Small Business Incentives

Several strategies to provide incentives to include space for Legacy Small Businesses are being recommended for incorporation into the zoning regulations for Boyle Heights.

The zoning regulations for all Form Districts across Boyle Heights are being modified such that any new building that incorporates space to “re-home” a Legacy Small Business may exempt the floor area for that business from its overall floor area calculation.

Additional strategies that are incorporated under Item A above include:

- The recommended Industrial Mixed-use District 6 (IX6) will allow for the location of a Legacy Small Business to count toward the 0.5 FAR Designated Production Space requirement that is placed on any new residential development projects. This item is recommended for action under section ii.
- The Community Benefits Program is being expanded to allow for non-residential projects to achieve bonus floor area by providing space for Legacy Small Businesses, within the IX6 Zoning District. This Item is recommended for action under section vi.

Recommendation

It is recommended that the City Council accept the zoning regulation strategies to provide incentives to include space for Legacy Small Businesses in Boyle Heights.

B.1–B.2 - Technical Modifications to Chapter 1A of the LAMC

The following technical modifications to Chapter 1A of the LAMC are suggested should the City Council elect to introduce the recommended Legacy Small Business Program.

B.1 LAMC Chapter 1A, Article 9 (Public Benefit Systems), Sec. 9.4. (General Incentive Programs)

Add Sec. 9.4.8 Legacy Small Business Program into Div. 9.4. (General Incentive Programs) of Article 9 (Public Benefit Systems) of Chapter 1A of the LAMC to read as follows:

Sec. 9.4.8. Legacy Small Business Program

A. Purpose

To create long-lasting opportunities for existing commercial tenants to remain in the communities they serve.

B. Eligibility

1. When an existing on-site building possesses one or more legacy small businesses and involves new construction, or when a new development is proposing to incorporate a legacy small business from an off-site location as a part of its development, such a development may qualify for this incentive program, as long as it abides by the eligibility requirements and standards of this section.

2. In order for a legacy small business to be eligible for this incentive program, it shall meet at least three of the following five standards:
 - a. Has been in continuous operation within a 2 mile radius of the project site within the City for at least 10 years with no break in its operations exceeding two years;
 - b. Has no more than 100 employees/shareholders;
 - c. The business includes employees that can serve multi-lingual members of the community;
 - d. Accepts government issued assistance such as Electronics Benefits Transfer (EBT);
 - e. Pays employees wages equivalent to or greater than those specified in Sec. 10.37.2 (Payment of Minimum Compensation to Employees) of Article 11 (Living Wage) of the Los Angeles Administrative Code.

C. Legacy Small Business Options

1. Preserving or Retaining a Legacy Small Business On-Site
 - a. When new construction retains a legacy small business or multiple legacy small businesses on the ground floor of a development, either by preservation of the tenant spaces or by the leasing of new tenant spaces to legacy small businesses, the floor area of those legacy small businesses may be exempted from the total floor area calculation of the new construction. Proof of retention may be provided by way of lease agreement, recorded covenant, and written confirmation and consent of the legacy small business owner.
2. Accommodating a Legacy Small Business On-Site From Another Location
 - a. When a new development can accommodate a legacy small business from another location, a developer may show proof of the accommodation of that legacy small business as a part of the new development by way of lease agreement, recorded covenant, and written confirmation and consent of the legacy small business owner. If such proof is provided, an exemption of floor area from the total floor area allowed may be granted to the development.

D. Incentives

1. Floor Area Exemption

a. Preserving

When preserving a legacy small business or businesses on-site, two times (2x) the existing total floor area of those tenant spaces may be exempted from the new construction's floor area calculation.

i. A legacy small business is considered preserved when its tenant space is not physically diminished nor demolished as a part of new construction.

ii. If an addition to a legacy small business' tenant space is proposed, only the existing floor area of the tenant space shall be used for the purpose of calculating this incentive.

b. Retaining

When leasing new tenant space to an existing legacy small business or businesses, two times (2x) the total floor area of those proposed tenant spaces may be exempted from the new construction's floor area calculation.

i. A legacy small business is considered retained when its tenant space existed at the address or site of the new construction, and proof of its continued existence at the site has been provided.

c. Accommodating

When accommodating a legacy small business or businesses on-site from an off-site location, two times (2x) the total floor area of the new, accommodated legacy small business may be exempted from the new construction's floor area calculation.

E. Measurement

1. Floor Area Exemption

For purposes of determining the total exempted floor area granted when preserving, retaining, or accommodating a legacy small business(s), the total floor area dedicated to the legacy small business(s), either on-site within the development, or off-site, shall be multiplied by two. This amount shall then be added to the total allowed floor area, based on the applied Form District FAR. This amount then becomes the total allowable floor area the project is entitled to.

F. Process

1. Administrative Review

Floor area exemption for legacy small businesses pursuant to this Section may be requested in accordance with Sec. 13B.3.1. (Administrative Review)

2. Annual Reporting

Projects receiving a floor area exemption pursuant to this Section shall demonstrate compliance by submitting an annual report to the Department of City Planning.

a. Annual Legacy Small Business Report

The Annual Legacy Small Business Report shall be provided by the property owner that delineates the following:

i. Occupancy status of the development.

ii. Occupancy status of the legacy small business.

iii. Evidence as to compliance with any requirements of this Section.

b. Non-Compliance

Non-compliance with the requirements of this Section shall result in either renewal of the term of the lease or legal action taken against the owner to comply with the contract.

c. Review

The Department of City Planning shall review the Annual Legacy Small Business Report pursuant to Sec. 13B.3.1. (Administrative Review).

G. Records and Agreements

1. Lease

a. A minimum 10-year lease with a small legacy business, with a 5 year renewal option shall be required prior to a City Planning administrative sign-off or case condition clearance pursuant to Sec. 13B.3.1. (Administrative Review).

b. This requirement does not mean that the legacy small business is required to complete the term of the lease. If the lease is not completed for the entirety of the 10-year term, the property owner or their representative shall find a new legacy small business to complete the 10-year term.

- c. Should the legacy small business decide to terminate the lease, the owner shall have up to 1 year from the date of the lease termination to establish a lease with a new legacy small business.

2. Covenant

A covenant acceptable to the Department of City Planning must be recorded with the Los Angeles County Recorder, guaranteeing that the applicant, tenant, or property owner will dedicate floor area within the development for a legacy small business for the periods outlined in this Section, and will submit annual reporting to the Department of City Planning in a manner consistent with Sec. 9.4.8.F.2. (Annual Reporting).

B.2 LAMC Chapter 1A, Article 14 (General Rules), Div. 14.2. (Glossary)

Add the term “Legacy Small Business” and its definition into Div. 14.2. (Glossary) of Article 14 (General Rules) of Chapter 1A of the LAMC to read as follows:

Legacy Small Business. Any business that is on the Citywide Legacy Business Registry, or a privately-owned corporation, cooperative, non-profit, social enterprise, or other entity that serves the neighborhood in which it is located, and is not franchised or affiliated with a national chain.

C.1 - Technical Modification

The following technical modification is suggested should the City Council elect to expand Subarea B.

C.1 Technical Modification: Boyle Heights Community Plan Implementation Overlay (CPIO) District

Add the identified parcels to the Boyle Heights Community Plan Implementation Overlay (CPIO) District (**Exhibit D1**) Subarea B – Historic Resources, as shown in Map C-1.

D. Technical Modifications to Chapter 1A of the Los Angeles Municipal Code

The following optional technical modifications are offered for the PLUM Committee's consideration in order to provide clarity and consistency in Chapter 1A of the LAMC.

D.1–D.32 - Technical Modifications to Chapter 1A of the LAMC

D.1 LAMC Chapter 1A, Article 2 (*Form Districts*), Sec. 2A.1.4 (*Form District Naming Convention*)

Modify Section 2A.1.4.C.1. of Article 2 (Form Districts) of Chapter 1A of the LAMC to read as follows:

1. FAR Category the first component of each Form District name is a floor area ratio (FAR) category. FAR categories group all districts within a range of maximum allowed FAR. FAR categories are organized as follows:
 - a. Very Low-Rise (>0.65 - 1.5 FAR)
 - b. Low-Rise (>1.5 - 4.0 FAR)
 - c. Mid-Rise (>4.0 - 6.0 FAR)
 - d. Moderate-Rise (>6.0 - 8.5 FAR)
 - e. High-Rise (>8.5 -13.0 FAR)

D.2 LAMC Chapter 1A, Article 2 (*Form Districts*)

Modify Article 2 (*Form Districts*) of Chapter 1A of the LAMC to update the Very-Low FAR range within the graphic on the first page of the following divisions, to read "0.6-1.5 FAR": update the Very Low FAR range within the graphic on the first page of each of the following Divisions to state ".6-1.5 FAR":

Div. 2B.4. (*Very Low-Rise Narrow Form Districts*), Div. 2B.5. (*Very Low-Rise Medium Form Districts*), Div. 2B.7 (*Very Low-Rise Full Form Districts*), Div. 2B.8. (*Low-Rise Narrow Form Districts*), Div. 2B.9. (*Low-Rise Medium Form Districts*), Div. 2B.11. (*Low-Rise Full Form Districts*), Div. 2B.12. (*Mid-Rise Narrow Form Districts*), Div. 2B.13. (*Mid-Rise Medium Form Districts*), Div. 2B.14. (*Mid-Rise Broad Form Districts*), Div. 2B.15. (*Mid-Rise Full Form Districts*), Div. 2B.16. (*Moderate-Rise Medium Form Districts*), Div. 2B.17. (*Moderate-Rise Broad Form Districts*), Div. 2B.19. (*High-Rise Medium Form Districts*), and Div. 2B.20. (*High-Rise Broad Form Districts*).

D.3 LAMC Chapter 1A, Article 2 (Form), Sec. 2B.8.1 (Low-Rise Narrow 1(LN1))

Add “District Boundary Height Transition” standard to B.2 Upper-Story Bulk to include a 45’ adjoining district allowed height (max), 10’ adjoining lot set-back (min), and 4 stories without height transition (max).

D.4 LAMC Chapter 1A, Article 5 (Use), Sec.5B.3.2. (Residential 2 (RG2)), Sec.5B.4.2. (Residential-Mixed 2(RX2)), Sec.5B.5.5 (Commercial-Mixed 5 (CX5)), Sec. 5B.7.5. (Industrial-Mixed 5 (IX5)), Sec.5B.8.8. (Industrial 3 (I3))

Remove Motor Vehicle Services, Commercial use from all use district tables as this use has been incorporated into the Motor Vehicle Services, the Motor Vehicle Services, Commercial row in the following sections Sec. 5B.3.2.B., Sec. 5B.4.2.B., Sec. 5B.5.5.B., Sec. 5B.7.5.B., Sec. 5B.8.8.B. (Allowed Use & Use Limitations) shall be amended as follows:

| | |
|--------------------------------|--------------|
| Motor Vehicle Services: | |
| Commercial | — |

D.5 LAMC Chapter 1A, Article 5 (Use), Sec. 5B.3.2. (Residential 2 (RG2))

To allow mobilehome park uses in use districts that also allow dwelling uses, the Mobilehome Park table row in Sec. 5B.3.2.B. (Allowed Use & Use Limitations) shall be amended as follows:

| | | | |
|------------------------|------------------|--------------------------|--------------------------|
| Mobilehome Park | <u>P*</u> | <u>Screening:</u> | |
| | | Frontage screen | <u>F-Screen 3</u> |
| | | Transition screen | <u>F-Screen 1</u> |
| | | <u>Relief</u> | <u>C2</u> |

D.6 LAMC Chapter 1A, Article 5 (Use), Sec. 5B.3.2. (Residential 2 (RG2))

To prohibit transitional shelter uses in use districts intended for Low Residential General Plan designations, the Supportive Housing, Transitional Shelter row in Sec. 5B.3.2.B. (Allowed Use & Use Limitations) shall be amended as follows:

| | |
|----------------------------|-----------------|
| Supportive Housing: | |
| Transitional Shelter | P -- |

D.7 LAMC Chapter 1A, Article 5 (Use), Sec. 5B.3.2. (Residential 2 (RG2))

To prohibit Equine, Non-commercial uses in use districts intended for Low Residential General Plan designations, the Agricultural Uses table, Animal Keeping, Equine, Non-commercial row in Sec. 5B.3.2.B. (Allowed Use & Use Limitations) shall be amended as follows:

| | |
|------------------------|------------------|
| Animal Keeping: | |
| Equine, Non-commercial | P* -- |

D.8 LAMC Chapter 1A, Article 5 (Use), Sec.5B.4.2. (Residential-Mixed 2 (RX2))

To allow mobilehome park uses in use districts that also allow dwelling uses, the Mobilehome Park table row in Sec. 5B.4.2.B. (Allowed Use & Use Limitations) shall be amended as follows:

| | | | |
|------------------------|---------------|-------------------|------------|
| Mobilehome Park | P* | Screening: | |
| | | Frontage screen | F-Screen 3 |
| | | Transition screen | F-Screen 1 |
| | | Relief | C2 |

D.9 LAMC Chapter 1A, Article 5 (Use), Sec.5B.4.2. (Residential-Mixed 2 (RX2))

To allow commercial indoor recreation uses in the Residential-Mixed 2 use district to align with the intent of the use district by supporting residential communities with commercial uses, local civic and recreational uses, the Indoor Recreation, Commercial table row in Sec. 5B.4.2.B. (Allowed Use & Use Limitations) shall be amended as follows:

| | | | |
|---------------------------|-------------|--|------------------------|
| Indoor Recreation: | | | |
| Commercial | — <u>P*</u> | <u>In conjunction with:</u> | <u>Residential use</u> |
| | | <u>Non-residential tenant size (max)</u> | <u>1,500 SF</u> |
| | | <u>Relief</u> | <u>Prohibited</u> |
| | | <u>Upper story location</u> | <u>Prohibited</u> |
| | | <u>Hours of operation (early/late)</u> | <u>6AM/10PM</u> |

D.10 LAMC Chapter 1A, Article 5 (Use), Sec.5B.4.2. (Residential-Mixed 2 (RX2))

To prohibit soundstage and backlot uses in use districts intended for Low Residential General Plan designations, the Soundstage & Backlot table row in Sec. 5B.4.2.B. (Allowed Use & Use Limitations) shall be amended as follows:

| | |
|-----------------------------------|------------------|
| Soundstages & Backlots | C3 -- |
|-----------------------------------|------------------|

D.11 LAMC Chapter 1A, Article 5 (Use), Sec.5B.5.5. (Commercial-Mixed 5 (CX5))

To allow mobilehome park uses in use districts that also allow dwelling uses, the Mobilehome Park table row in Sec. 5B.5.5.B. (Allowed Use & Use Limitations) shall be amended as follows:

| | | | |
|------------------------|-------------|--------------------------|-------------------|
| Mobilehome Park | — <u>P*</u> | <u>Screening:</u> | |
| | | <u>Frontage screen</u> | <u>F-Screen 3</u> |
| | | <u>Transition screen</u> | <u>F-Screen 1</u> |
| | | <u>Relief</u> | <u>C2</u> |

D.12 LAMC Chapter 1A, Article 5 (Use), Sec.5B.5.5. (Commercial-Mixed 5 (CX5))

To allow post-secondary school uses through a conditional use permit with a hearing by the Zoning Administrator, the School, Post-secondary table row in Sec. 5B.5.5.B. (Allowed Use & Use Limitations) shall be amended as follows:

| | |
|----------------|-------------------------|
| School: | |
| Post-secondary | C3 <u>C2</u> |

D.13 LAMC Chapter 1A, Article 5 (Use), Sec.5B.5.5. (Commercial-Mixed 5 (CX5))

| | | | |
|-------------------|------------------|----------------------------------|-----|
| School: | | | |
| Preschool/Daycare | P* -- | Use separation | |
| | | From Heavy Industrial | 50' |
| | | Relief | C2 |

To allow veterinary care uses in the Commercial-Mixed 5 use district to align with the intent of the use district by supporting the clustering of small-scale retail, dining, personal, service, office, entertainment, cultural and institutional uses catering to immediately surrounding neighborhoods, the Animal Services, Veterinary Care table row in Sec. 5B.5.5.B. (Allowed Use & Use Limitations) shall be amended as follows:

| | | | |
|-------------------------|---------------|---------------------------------|---------------------|
| Animal Services: | | | |
| Veterinary Care | P* | <i>(see General Commercial)</i> | |
| | | Use enclosure | Fully indoor |

D.14 LAMC Chapter 1A, Article 5 (Use), Sec.5B.7.5. (Industrial-Mixed 5 (IX5))

To prohibit transitional shelter uses in use districts that prohibit dwelling uses, the Supportive Housing, General table row in Sec. 5B.7.5.B. (Allowed Use & Use Limitations) shall be amended as follows:

| | |
|----------------------------|------------------|
| Supportive Housing: | |
| General | P* -- |

D.15 LAMC Chapter 1A, Article 5 (Use), Sec.5B.7.5. (Industrial-Mixed 5 (IX5))

To prohibit preschool/daycare uses in use districts that are primarily intended to accommodate light industrial uses, the School, Preschool/Daycare table row in Sec. 5B.7.5.B. (Allowed Use & Use Limitations) shall be amended as follows:

D.16 LAMC Chapter 1A, Article 5 (Use), Sec.5B.7.5. (Industrial-Mixed 5 (IX5))

To prohibit heavy transportation uses, including freight terminal uses, in use districts that are primarily intended to accommodate light industrial uses, the Freight Terminal table row in Sec. 5B.7.5.B. (Allowed Use & Use Limitations) shall be amended as follows:

| | |
|-------------------------|------------------|
| Freight Terminal | C3 -- |
|-------------------------|------------------|

D.17 LAMC Chapter 1A, Article 5 (Use), Sec.5B.7.5. (Industrial-Mixed 5 (IX5))

To prohibit heavy transportation uses, including railway facility uses, in use districts that are primarily intended to accommodate light industrial uses, the Railway Facility table row in Sec. 5B.7.5.B. (Allowed Use & Use Limitations) shall be amended as follows:

| | |
|------------------|------------------|
| Railway Facility | C3 -- |
|------------------|------------------|

D.18 LAMC Chapter 1A, Article 5 (Use), Sec.5B.7.5. (Industrial-Mixed 5 (IX5))

To require regional entertainment venue uses to obtain a conditional use permit to consider regional impacts on land primarily intended to accommodate light industrial uses, the Entertainment Venue, Regional row in Sec. 5B.7.5.B. (Allowed Use & Use Limitations) shall be amended as follows:

| | |
|--------------------------------|------------------------|
| Entertainment Venue: | |
| Regional (3,000 or more seats) | P <u>C3</u> |

D.19 LAMC Chapter 1A, Article 5 (Use), Sec.5B.7.5. (Industrial-Mixed 5 (IX5))

To require alternative financial service uses to obtain a conditional use permit to consider local impacts on land primarily intended to accommodate light industrial uses, the Financial Services, Alternative row in Sec. 5B.7.5.B. (Allowed Use & Use Limitations) shall be amended as follows:

| | |
|----------------------------|------------------------|
| Financial Services: | |
| Alternative | P <u>C2</u> |

D.20 LAMC Chapter 1A, Article 5 (Use), Sec.5B.7.5. (Industrial-Mixed 5 (IX5))

To allow postmortem service uses on land intended to accommodate light industrial uses, as well as commercial services that need to be accommodated away from residential use districts, the Postmortem Services row in Sec. 5B.7.5.B. (Allowed Use & Use Limitations) shall be amended as follows:

| | |
|---------------------|------------------------|
| Postmortem Services | C2 <u>P</u> |
|---------------------|------------------------|

D.21 LAMC Chapter 1A, Article 5 (Use), Sec.5B.7.5. (Industrial-Mixed 5 (IX5))

To update the permission level for alcohol retail sales to indicate that the Alcohol Sales Special Use Program applies, the Retail, Alcohol row in Sec. 5B.7.5.B. (Allowed Use & Use Limitations) shall be amended as follows:

| | | | |
|----------------|------------------------|----------------------------|--------------|
| Retail: | | | |
| Alcohol | S <u>S*</u> | Special use program | |
| | | Alcohol sales program | Sec. 5C.4.2. |

D.22 LAMC Chapter 1A, Article 5 (Use), Sec.5B.7.5. (Industrial-Mixed 5 (IX5))

To require certified farmers’ market uses to obtain approval by the Zoning Administrator through a conditional use permit to consider local impacts, the Farmers’ Market, Certified row in Sec. 5B.7.5.B. (Allowed Use & Use Limitations) shall be amended as follows:

| | |
|----------------------------|-------------------------|
| Retail: | |
| Farmers’ Market, Certified | P <u>C1*</u> |

D.23 LAMC Chapter 1A, Article 5 (Use), Sec.5B.7.5. (Industrial-Mixed 5 (IX5))

To allow sexual encounter uses on land intended to accommodate light industrial uses, as well as commercial uses that need to be accommodated away from residential use districts, the Sexual Encounter row in Sec. 5B.7.5.B. (Allowed Use & Use Limitations) shall be amended as follows:

| | |
|------------------------------------|--------------------------|
| Sexually Oriented Business: | |
| Sexual Encounter | C2* <u>P*</u> |

D.24 LAMC Chapter 1A, Article 5 (Use), Sec.5B.7.5. (Industrial-Mixed 5 (IX5))

To allow standard vehicle sales uses on land intended to accommodate light industrial uses, as well as commercial uses that need to be accommodated away from residential use districts, the Motor Vehicle Sales & Rental row in Sec. 5B.7.5.B. (Allowed Use & Use Limitations) shall be amended as follows:

| | | | |
|--|------------------------|---|-------------------|
| Motor Vehicle Sales & Rental: | | | |
| Standard Vehicle | M <u>P*</u> | <u>Use separation (min)</u> | |
| | | <u>Sensitive use</u> | <u>200'</u> |
| | | <u>Agricultural, Residential, or Residential-Mixed Use District</u> | <u>200'</u> |
| | | <u>Relief</u> | <u>C2</u> |
| | | <u>Screening:</u> | |
| | | <u>Frontage screen</u> | <u>F-Screen 4</u> |

| | | |
|--|-------------------|------------|
| | Transition screen | F-Screen 1 |
|--|-------------------|------------|

D.25 LAMC Chapter 1A, Article 7 (Alternate Typologies), SEC. 7B.3.1. (SMALL LOT 1)

Modify Section 7B.3.1.A.1. of Article 7 the new Zoning Code to read as follows, for the purpose of aligning the density districts to match where Small Lot projects are allowed in Sec 12.22 C.27(a) of the current Zoning Code (Chapter 1 of the LAMC). Small Lot projects in the current Zoning Code are allowed in multi-family, commercial and RD zones. The most restrictive RD zone is the RD6 zone. Therefore Small Lot projects shall be allowed in the density district range FA to 60.

| | | | | | |
|-----------------------|---------|---------------------|--------------|--------------------------|------------------------------------|
| 1. Eligible Districts | FORM | FRONTAGE | STANDARD | USE | DENSITY |
| | V_ & L_ | MU_, G_, LF_, & WH_ | 1, 2, 3, & 4 | RG_, RX_, C_, CX_, & IX_ | FA through 25 60 |

D.26 LAMC Chapter 1A, Article 7 (Alternate Typologies), SEC. 7B.3.1.D. (Form Standards)

Modify Lot Parameter Standards in Sec 7B.3.1.D.1. of Article 7 the new Zoning Code to read as follows, for the purpose of aligning standards to scale better with the applied districts, certain standards shall be set by the form district. The minimum lot area and minimum lot width shall be set by the form district.

| LOT SIZE | Sec. 7C.1.1. | |
|--------------------------|---------------------|-----------------------------|
| A Lot area (min) | 5,000 SF | Set by Form District |
| B Lot width (min) | 50' | Set by Form District |

D.27 LAMC Chapter 1A, Article 7 (Alternate Typologies), SEC. 7B.3.1.D. (Form Standards)

Modify Bulk and Mass Standards in Sec 7B.3.1.D.2. of Article 7 the new Zoning Code to read as follows, the building width of 180 feet can never be reached as the maximum allowed lot width in this alternate typology is 80 feet. The maximum building width shall be 75 feet to align better with the maximum allowed lot width.

| BUILDING MASS | Sec. 7C.1.1. | |
|-------------------------------|-----------------|------------|
| B Building width (max) | 180' | 75' |

D.28 LAMC Chapter 1A, Article 7 (Alternate Typologies), SEC. 7B.3.1.F. (Development Standards)

Section 7B.3.1.F.1.a.i. of Article 7 of Chapter 1A of the Los Angeles Municipal Code shall be amended to read as follows, for the purpose of distinguishing the difference between the street facing entrance pedestrian accessway and the pedestrian accessway for internal circulation.

- a. Small lot subdivisions shall provide a shared pedestrian accessway meeting the following Standards:
 - i. The pedestrian accessway providing site access to any street facing entrance required by the applicable frontage district shall have a minimum width of 4 feet. All pedestrian accessways that are used for internal circulation, such as leading to other entrances or amenity spaces shall have a minimum width of 3 feet and shall be open to sky.

D.29 LAMC Chapter 1A, Article 7 (Alternate Typologies), SEC. 7B.3.1.F. (Development Standards)

Section 7B.3.1.F.2. of Article 7 Chapter 1A of the LAMC shall be amended to read as follows, for the purpose of aligning standards to match those of Small Lot projects allowed in Sec 12.22 C.27(a)(2) of the current Zoning Code. Certain wall designs are prohibited from being used as side and rear perimeter walls.

2. Side/rear yard Fence and wall

All fences and walls provided shall not include barbed wire, or concertina.

~~2. Additional Rules~~

~~For additional Development Standards rules, see the applied Development Standard District (Part 4B.) and Development Standards Rules (Part 4C).~~

3. Additional Rules

For additional Development Standards rules, see the applied Development Standard District (Part 4B.) and Development Standards Rules (Part 4C).

D.30 LAMC Chapter 1A, Article 9 (Public Benefit Systems), SEC. 9.3.2. (Local Affordable Housing Incentive Program)

Section 9.3.2.B.1.a of Chapter 1A of the LAMC shall be amended to read as follows:

| LOCAL INCENTIVE PROGRAM SETS | | | | | |
|------------------------------|----------------------------|----------------------|-----------------|--------------|----------|
| Set | Affordability Requirements | | | | |
| | ACUTELY LOW INCOME | EXTREMELY LOW INCOME | VERY LOW INCOME | LOWER INCOME | MODERATE |
| A | n/a | 11% | 15% | 25% | n/a |
| B | 10% | 11% | 15% | 25% | n/a |
| C | n/a | 10% | 14% | 23% | n/a |
| D | n/a | 10% | 14% | 23% | n/a |
| E | n/a | 9% | 12% | 21% | n/a |
| F | n/a | 8% | 11% | 20% | n/a |
| G | 7% | 8% | 11% | 20% | 40% |

D.31 LAMC Chapter 1A, Article 14 (Definitions), Sec. 14.1.7. (Floor Area)

Sub-subparagraph iii of Section 14.1.7.A.1.c. (Floor Area, Measurement, General) of Chapter 1A of the LAMC shall be amended to read as follows:

iii. All interior floor space dedicated to automobile parking except as specified in Sec. 14.1.7.A.2. (~~House Form Districts~~ Density Districts 1L and 2L) and Sec. 14.1.7.A.3. (Development Standards District 5).

D.32 LAMC Chapter 1A, Article 14 (Definitions), Sec. 14.1.7. (Floor Area)

The title of Section 14.1.7.A.2. (Floor Area, Measurement, House Form Districts) of Chapter 1A of the LAMC shall be amended to read as follows:

2. ~~House Form Districts~~ Density Districts 1L and 2L

E. Technical Modification to General Plan Designations

The following modifications are offered for the PLUM Committee's consideration in order to execute a technical name change in the Form District Naming Convention is required in the new zoning code. The update includes modifying the "Very Low Rise Narrow (VN1)" to "House (H3)" for consistency with how Form Districts will be named elsewhere throughout the City.

E.1–E.6 - Technical Modification

The following additional modifications would be required to execute the technical name change:

E.1 Technical Modification: Community Plan Text

Amend the description of the General Plan Land Use Designations for the Low Residential, Low Medium Residential, and Low Neighborhood Residential to replace the "Very Low Rise" references to "House" in the Boyle Heights Community Plan policy document identified as, "**Exhibit C1 Community Plan Text**," and

E.2 Technical Modification: General Plan Land Use Map

Amend the General Plan Land Use Map (**Exhibit C3**) to replace VN1 to H3 in the corresponding table, and

E.3 Technical Modification: General Plan Framework Amendments

Amend the descriptions for Low Residential, Low Medium Residential, and Low Neighborhood Residential designations by replacing "Very Low Rise" to "House" in the Citywide General Plan Framework Element identified as, "**Exhibit C5 General Plan Framework Amendments**," and

E.4 Technical Modification: General Plan Framework Amendments

Amend Table 3-3a and Table 3-2a by replacing "Very-Low Rise" with "House" in the Citywide General Plan Framework Element identified as, "**Exhibit C5 General Plan Framework Amendments**".

Effectuating these General Plan Amendments would also require modifications to the following ordinances:

E.5 Technical Modification: Zone Change Map and Matrices

Amend the draft ordinance to amend the Zoning Map identified as, "**Exhibit D2 Zone Change Map and Matrices**" to replace "VN1" references to H3.

E.6 Technical Modification: Ordinance Amending Chapter 1A of the Los Angeles Municipal Code

Rename the Very Low-Rise 1 (VN1) Form District (found in Sec. 2B.4.1. of “**Exhibit E1 Ordinance Amending Chapter 1A of the Los Angeles Municipal Code**”) to House 3 and to include a description of the House Form District within Sec. 2A.1.4. (Form District Naming Convention) accordingly.

Sincerely,

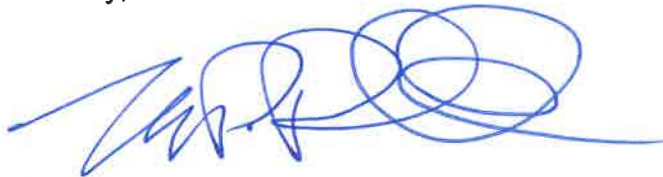
A handwritten signature in blue ink, appearing to read 'Vincent P. Bertoni', with a stylized, looping flourish at the end.

VINCENT P. BERTONI, AICP
Director of Planning

VPB:SMMB:cw:ug:ap

Appendix I - IX6 Use District

FRONTAGE • MEMBERS • USE DENSITY
 - Industrial-Mixed Districts -

SEC. 5B.7.6. INDUSTRIAL-MIXED, TRANSITION (IX6)

A. Intent

Reserved.

B. Allowed Uses & Use Limitations

| Use | Permission | Use Standard | Specification |
|--|------------|--|--|
| RESIDENTIAL | * | Use Separation (min) Heavy Industrial Relief | 50' C1 |
| Dwelling | S* | (see Residential) In conjunction with: Floor Area (min) Inclusionary Housing Program | Manufacturing, Light: General, Artistic & Artisanal, and/or Garment & Accessory and/or Legacy Small Business (Sec.5C.4.6.) 0.5 FAR Sec. 5C.4.5. |
| Household Business: Family Child Care | P* | In conjunction with: | Dwelling |
| Home Occupation | P* | In conjunction with: Hours of operation (early/late) Client visits per hour (max) Supplemental standards | Dwelling 8AM/8PM 1 Sec. 5B.7.6.C.1. |
| Home Sharing | P* | In conjunction with: Special use program (see Residential) | Dwelling Sec. 5C.4.4. |
| Joint Living & Work Quarters | P* | Designated work space: Work space area (min/max) | |
| Live/Work | S* | (see Residential) Designated work space Work space dimensions (min) Location Inclusionary Housing Program | Depth: 20' Width: 15' (frontage) Height: 14' Ground floor Sec. 5C.4.5. |
| Mobilehome Park | -- | | |
| Supportive Housing: | | | |
| General | P* | (see Residential) Restricted affordable units | 100% |
| Medical Care | P* | (see Residential) | |

KEY: "P"= Permitted Use; "S"= Special Use Program; "--"= Use Not Permitted; "*"= Use standard applies; "C1"= Approval by Zoning Administrator; "C2"= Public Hearing by Zoning Administrator; "C3"= Review by City Planning Commission

FRONTAGE - STANDARDS | **USE** DENSITY |
 - Industrial-Mixed Districts -

| Use | Permission | Use Standard | Specification |
|------------------------------------|------------|--|-------------------|
| Medical Care | P* | (see Residential) | |
| Transitional Shelter | P* | (see Residential) | |
| PUBLIC & INSTITUTIONAL | | | |
| Cemetery | P* | Building separation (min) | |
| | | Street | 300' |
| | | Agricultural, Residential, or Residential Mixed Use District | 300' |
| | | Screening | |
| | | Frontage screen | F-Screen 2 |
| | | Transition screen | T-Screen 1 |
| Civic Facility: | | | |
| Local | P | | |
| Regional | -- | | |
| Detention Facility | C3 | | |
| | | Screening | |
| Fleet Services | P* | Frontage screen | F-Screen 3 |
| | | Transition screen | T-Screen 1 |
| Medical: | | | |
| Local | C2 | | |
| Regional | C3 | | |
| Office, Government | P | | |
| Parking | P | | |
| Public Safety Facility | P | | |
| Religious Assembly | C2 | | |
| School: | | | |
| Preschool/Daycare | P | | |
| K-12 | C3 | | |
| Post-secondary | C2 | | |
| Social Services | P | | |
| Utilities: | | | |
| Minor | P* | Screening | |
| | | Frontage screen | F-Screen 2 |
| | | Transition screen | T-Screen 2 |
| Major | C3 | | |
| Solar Energy Facility | P* | In conjunction with: | Other allowed use |
| | | Floor area (min) | 0.1 FAR |
| | | Relief | C3 |
| Wireless Facility, Monopole | C2* | Supplemental standards | Sec. 5B.76.C.2. |
| Wireless Facility, Rooftop | P* | Supplemental standards | Sec. 5B.76.C.2. |
| OPEN SPACE & RECREATION | | | |
| Indoor Recreation | | | |

KEY: "P" = Permitted Use; "S" = Special Use Program; "--" = Use Not Permitted; "*" = Use standard applies; "C1" = Approval by Zoning Administrator; "C2" = Public Hearing by Zoning Administrator; "C3" = Review by City Planning Commission

| Use | Permission | Use Standard | Specification |
|-------------------------------------|------------|---|--|
| Public | P | | |
| Commercial | P | | |
| Nature Reserve | P | | |
| Open Space, Public | P | | |
| Outdoor Recreation | | | |
| Public | P | | |
| Commercial | P | | |
| Golf Course | -- | | |
| Amphitheater or Stadium | | | |
| Local | P* | Use separation (min) Agricultural, Residential or Residential Mixed Use District | 500' |
| | | Relief | C2 |
| Regional | C3 | | |
| TRANSPORTATION | | | |
| Airport | -- | | |
| Freight Terminal | -- | | |
| Heliport | C2* | Incidental to: | Residential Uses, Office or Medical |
| Railway Facility | -- | | |
| Transit Station | P | | |
| GENERAL COMMERCIAL | | | |
| Animal Services: | | | |
| General | P* | Use enclosure | Fully Indoor |
| Kennel | P* | Use enclosure | Fully indoor |
| | | Use separation | |
| | | Residential Use District (min) | 500' |
| | | Relief | C2 |
| Veterinary Care | P* | Use enclosure | Fully indoor |
| Commissary Kitchen | P | | |
| Eating & Drinking: | | | |
| Alcohol Service | C2* | In conjunction with: Supplemental procedures | Restaurant Sec. 5B.76.D.1 |
| Bar | C2* | Supplemental procedures | Sec. 5B.76.D.1 |
| Counter Service | P | | |
| Restaurant | P | | |
| Entertainment Venue, Indoor: | | | |
| Local (<3,000 seats) | P | | |
| Regional (3,000 or more seats) | C3 | | |
| Financial Services: | | | |
| General | P | | |
| Alternative | C2 | | |

KEY: "P"= Permitted Use; "S"= Special Use Program; "--"= Use Not Permitted; "*" = Use standard applies; "C1" = Approval by Zoning Administrator; "C2" = Public Hearing by Zoning Administrator; "C3" = Review by City Planning Commission

FROM (R/DA/C/S/D/S) USE - DENY
 - Industrial-Mixed Districts -

| Use | Permission | Use Standard | Specification |
|-----------------------------|------------|--|-----------------|
| Instructional Services | P | | |
| Lodging | P* | Use separation | |
| | | Agricultural, Residential, or Residential Mixed Use District | 500' |
| | | Supplemental standards | Sec. 5B.76.C.3. |
| | | Relief | C2 |
| Medical Clinic | P | | |
| Office | P | | |
| Personal Services: | | | |
| General | P | | |
| Massage, Licensed | P | | |
| Massage, Unlicensed | C2 | | |
| Postmortem Services | P | | |
| Retail: | | | |
| General | P | | |
| Alcohol | C2* | Supplemental procedures | Sec. 5B.76.D.2. |
| Farmers' Market, Certified | C1* | Hours of operation (open/close) | 7AM/9PM |
| | | Service hours | 6AM/10PM |
| | | Operating days per week (max) | 2 |
| | | Special use program | Sec. 5C.4.1 |
| Firearms | C2 | Use separation (min) | |
| | | Agricultural, Residential, or Residential Mixed Use District | 500' |
| | | Supplemental procedures | Sec. 5B.76.D.3. |
| Food & Beverage | P | | |
| Large Format | C3* | Supplemental procedures | Sec. 5B.76.D.4. |
| Merchant Market | P | | |
| Pet Shop | P | | |
| Temporary Outdoor | C2 | | |
| Smoke & Vape Shop | P* | Use separation (min) | |
| | | School: K-12 | 500' |
| | | Relief | C2 |
| Sexually Oriented Business: | | | |
| General | P* | Use separation (min) | |
| | | Other Sexually Oriented Business Use | 1,000' |
| | | Sensitive Use | 500' |
| | | Agricultural, Residential, or Residential Mixed Use District (min) | 500' |

KEY: "P" = Permitted Use; "S" = Special Use Program; "--" = Use Not Permitted; "*" = Use standard applies; "C1" = Approval by Zoning Administrator; "C2" = Public Hearing by Zoning Administrator; "C3" = Review by City Planning Commission

| Use | Permission | Use Standard | Specification |
|----------------------------|-----------------|--|---------------|
| Sexual Encounter | C2* | Use separation (min) | |
| | | Other Sexually Oriented Business Use | 1,000' |
| | | Sensitive Use | 500' |
| | | Agricultural, Residential, or Residential Mixed Use District | 500' |
| HEAVY COMMERCIAL | | | |
| Motor Vehicle Services: | | | |
| Light | P* | Use separation (min) | |
| | | Sensitive use | 200' |
| | | Agricultural, Residential, or Residential Mixed Use District | 200' |
| | | Relief | C2 |
| | | Use enclosure | Fully indoors |
| | | Screening | |
| | | Frontage screen | F-Screen 3 |
| | | Transition screen | T-Screen 1 |
| | | Hours of operation (open/close) | 7AM/7PM |
| | | Service hours (open/close) | 7AM/7PM |
| Outdoor sound system | Prohibited | | |
| Supplemental standards | Sec. 5B.76.C.4. | | |
| Heavy | -- | | |
| Car Wash | C2* | Use separation (min) | |
| | | Sensitive use | 200' |
| | | Agricultural, Residential, or Residential Mixed Use District (min) | 200' |
| | | Use enclosure | |
| | | Car Wash, mechanized | Fully indoors |
| | | Car Wash, self-service | Covered |
| | | Screening | |
| | | Frontage screen | F-Screen 3 |
| | | Transition screen | T-Screen 1 |
| | | Hours of operation (open/close) | 7AM/7PM |
| Service hours (open/close) | 7AM/7PM | | |
| Outdoor sound system | Prohibited | | |
| Supplemental standards | Sec. 5B.76.C.5. | | |
| Fueling Station: | | | |

KEY: "P" = Permitted Use; "S" = Special Use Program; "--" = Use Not Permitted; "*" = Use standard applies; "C1" = Approval by Zoning Administrator; "C2" = Public Hearing by Zoning Administrator; "C3" = Review by City Planning Commission

FORM - FRONTAGE STANDARDS | USE DENSITY |
 - Industrial-Mixed Districts -

| Use | Permission | Use Standard | Specification |
|-------------------------------|------------|--|----------------------|
| Gas Station, Standard | C2* | Use separation (min) | |
| | | Sensitive use | 200' |
| | | Agricultural, Residential, or Residential Mixed Use District (min) | 200' |
| | | Screening | |
| | | Frontage screen | F-Screen 3 |
| | | Transition screen | T-Screen 1 |
| | | Outdoor sound system | Prohibited |
| | | Supplemental standards | Sec. 5B.76.C.6. |
| Gas Station, Commercial | P* | Use separation (min) | |
| | | Sensitive use | 200' |
| | | Agricultural, Residential, or Residential Mixed Use District | 200' |
| | | Relief | C2 |
| | | Screening | |
| | | Frontage screen | F-Screen 3 |
| | | Transition screen | T-Screen 1 |
| | | Outdoor sound system | Prohibited |
| | | Supplemental standards | Sec. 5B.76.C.6. |
| EV Charging Facility | P | | |
| Motor Vehicle Sales & Rental: | | | |
| Commercial Vehicle | -- | | |
| Household Moving Truck Rental | C2* | Accessory to: | Self-Service Storage |
| | | Screening | |
| | | Frontage screen | F-Screen 3 |
| | | Transition screen | T-Screen 1 |
| Standard Vehicle | C2* | Screening | |
| | | Frontage screen | F-Screen 3 |
| | | Transition screen | T-Screen 1 |
| Storage, Indoor: | | | |
| General | P* | Incidental to: | Other allowed use |
| Self-Service Facility | P* | In conjunction with: | Other allowed use |
| | | Floor area (min) | 0.1 FAR |
| | | Use separation (min) | |
| | | Other Self-Service Facility | 500' |
| | | Relief | C2 |
| | | Supplemental procedures | Sec. 5B.76.D.5. |
| Storage, Outdoor: | | | |
| General | -- | | |

KEY: "P" = Permitted Use; "S" = Special Use Program; "--" = Use Not Permitted; "*" = Use standard applies; "C1" = Approval by Zoning Administrator; "C2" = Public Hearing by Zoning Administrator; "C3" = Review by City Planning Commission

| Use | Permission | Use Standard | Specification |
|--------------------------------|--------------|----------------------------|---|
| Cargo Container | -- | | |
| Commercial Vehicle | -- | | |
| Official Motor Vehicle Impound | -- | | |
| Standard Vehicle | -- | | |
| LIGHT INDUSTRIAL | * | Use standard applicability | |
| | | Abutting | Sensitive Use, Agricultural Residential or Residential Mixed Use District |
| | | Screening | |
| | | Transition Screen | T-Screen 1 |
| Use enclosure | Fully Indoor | | |
| Electronics Assembly | P* | (see Light Industrial) | |
| Maintenance & Repair Services | P* | (see Light Industrial) | |
| Manufacturing, Light: | | | |
| General | P* | (see Light Industrial) | |
| Alcoholic Beverage | P* | (see Light Industrial) | |
| Artistic & Artisanal | P | | |
| Cosmetic, Pharmaceutical | P* | (see Light Industrial) | |
| Food & Drink | P* | (see Light Industrial) | |
| Textile & Apparel | P* | (see Light Industrial) | |
| Research & Development | P* | (see Light Industrial) | |
| Soundstages & Backlots | P* | (see Light Industrial) | |
| Wholesale Trade & Warehousing | C3* | Supplemental procedures | Sec. 5B.76.D.6. |
| HEAVY INDUSTRIAL | | | |
| Animal Products Processing | -- | | |
| Manufacturing, Heavy: | | | |
| General | -- | | |
| Chemical Products | -- | | |
| Petroleum & Coal Products | -- | | |
| Salvage Yard | -- | | |
| Recycling Facility: | | | |

KEY: "P"= Permitted Use; "S"= Special Use Program; "--"= Use Not Permitted; "*" = Use standard applies; "C1" = Approval by Zoning Administrator; "C2" = Public Hearing by Zoning Administrator; "C3" = Review by City Planning Commission

FRONTAGE - SCREENING | **USE** - DENSITY |
 - Industrial-Mixed Districts -

| Use | Permission | Use Standard | Specification |
|---|---|--|----------------------|
| Collection | P* | In conjunction with | Other allowed use |
| | | Area (max) | 600 SF |
| | | Building separation (min) | |
| | | Agricultural, Residential, or Residential Mixed Use District | 150' |
| | | Other buildings on site | 10' |
| | | Relief | C2 |
| | | Use enclosure | Covered and enclosed |
| | | Screening | |
| | | Outdoor storage screen | S-Screen 2 |
| | | Hours of operation (early/late) | 7AM/7PM |
| | | Supplemental standards | Sec. 5B.76.C.7. |
| | | Supplemental procedures | Sec. 5B.76.D.7. |
| | | Donation Bin | P* |
| Size | Height: 82' Depth: 50' Width: 60' | | |
| Use setback | | | |
| Frontage lot line (min) | 20' | | |
| Common lot line (min) | 10' | | |
| Use enclosure | Covered and enclosed | | |
| Supplemental standards | Sec. 5B.76.C.8. | | |
| Supplemental procedures | Sec. 5B.76.D.7. | | |
| Sorting & Processing | -- | | |
| Resource Extraction: | | | |
| General | -- | | |
| Exploratory Core Hole | C2* | Supplemental standards | Sec. 5B.76.C.9. |
| Off-Shore Drilling Servicing Installation | -- | | |
| Solid Waste Facility: | | | |
| Green Waste | -- | | |
| Hazardous Waste Facility | -- | | |
| Solid Waste | -- | | |
| AGRICULTURAL | | | |
| Animal Keeping: | | | |

KEY: "P"= Permitted Use; "S"= Special Use Program; "--"= Use Not Permitted; "*" = Use standard applies; "C1"= Approval by Zoning Administrator; "C2"= Public Hearing by Zoning Administrator; "C3"= Review by City Planning Commission

| Use | Permission | Use Standard | Specification |
|------------------------|------------|--------------------------------|-------------------|
| Bees | P* | Lot Area (min) | |
| | | Per beehive | 2,500 SF |
| | | Location | |
| | | Frontage yard | Prohibited |
| | | Setback (min) | |
| | | Side, rear and alley lot lines | 5' |
| | | Screening | |
| | | Transition screen | T-Screen 1 |
| | | Exception | Rooftop location |
| | | Supplemental standards | Sec. 5B.76.C.10. |
| Dairy | -- | | |
| Equine, Commercial | -- | | |
| Equine, Non-commercial | -- | | |
| Livestock | -- | | |
| Pets | P* | In conjunction with: | Other allowed use |
| Small Animals | -- | | |
| Wild Animals | -- | | |
| Plant Cultivation: | | | |
| Community Garden | P | | |
| Farming | P* | Use enclosure | Fully indoor |
| Truck Gardening | P | | |

KEY: "P" = Permitted Use; "S" = Special Use Program; "--" = Use Not Permitted; "*" = Use standard applies; "C1" = Approval by Zoning Administrator; "C2" = Public Hearing by Zoning Administrator; "C3" = Review by City Planning Commission

C. Supplemental Standards

1. Home Occupation

On-site deliveries and shipments related to the commercial use in a home occupation shall not be performed by vehicles having a gross vehicular weight rating designation greater than Class 4 or greater than 16,000 pounds. Deliveries from larger trucks shall occur no more frequently than once every 2 months.

2. Wireless Facility, All

The wireless facility shall meet all applicable standards required by *Sec. 4C.12.4. (Wireless Telecommunication Facilities)*.

3. Lodging

A Lodging use shall not be permitted where it requires a change of use from any residential use.

4. Motor Vehicle Services, Light & Heavy

a. Bay doors and other building entrances and exits designed and intended for motor vehicle access shall meet the following standards:

- i. Shall remain closed except during the allowed hours of operation, and
- ii. Shall not face any frontage lot line.

b. An off-street loading area, in compliance with development standard requirements for loading areas (*Sec. 4C.2.2.3.*), shall be provided to adequately accommodate all loading, unloading, and any other activities requiring the use of commercial vehicles for transportation.

c. All client vehicles being serviced by a general motor vehicle service use shall be stored on-site.

5. Motor Vehicle Services, Car Wash

Bay doors and other building entrances and exits designed and intended for motor vehicles shall not face any residential use or school unless the residential use or school is located more than 100 feet from the car wash facility.

6. Fueling Station, All

An off-street loading area, in compliance with development standard requirements for loading areas (*Sec. 4C.2.2.3.*), shall be provided to adequately accommodate all loading and unloading of fuel, vehicles, goods, and any other activities requiring the use of commercial vehicles for transportation.

7 Recycling Facility, Collection

- a. All deposited goods and materials, temporary installations, debris, trash, and any other material associated with the use shall be placed or stored in a fully covered and enclosed recycling facility, and not be left or stored outdoors beyond the hours of operation.
- b. Collection facilities shall be emptied in accordance with their posted pick-up schedule, and the area surrounding the collection bins shall be maintained free of overflow goods and materials, litter, debris, posted bills, and graffiti at all times.
- c. In order to prevent unauthorized access to the collection facility, a tamper-resistant locking mechanism shall secure the opening of the collection facility.
- d. The receptacle, container, or bin in which goods and materials are stored shall be fabricated of durable, noncombustible, and waterproof materials.
- e. The recycling collection facility enclosure shall be clearly identified with the operator's name, address, and telephone number, the lot owner's name, address of the lot, the types of items or materials that may be deposited, the pick-up schedule, a notice that no material shall be left outside the enclosure, and instructions to call 311 to register any complaint regarding the facility with the Department of Building and Safety.

8. Recycling Facility, Donation Bin

- a. No more than one collection bin shall be located on any lot.
- b. Collection bins shall be emptied in accordance with their posted pick-up schedule, and the area surrounding the collection bins shall be maintained free of overflow goods and materials, litter, debris, posted bills, and graffiti at all times.
- c. In order to prevent unauthorized access to the collection bin, a tamper-resistant locking mechanism shall secure the opening of the collection bin.
- d. The collection bin shall be fabricated of durable, noncombustible, and waterproof materials.
- e. Collection bins shall be illuminated between sunset and sunrise by a light source providing at least 1 footcandle of light.
- f. The collection bin shall be clearly identified with the operator's name, address, and telephone number, the lot owner's name, address of the lot, the types of items or materials that may be deposited, the pick-up schedule, a notice that no material shall be left outside the enclosure, and instructions to call 311 to register any complaint regarding the collection bin with the Department of Building and Safety.

9 Resource Extraction, Exploratory Core Hole

The maximum duration of a permit for exploratory core holes shall not exceed 200 days. However, where the Zoning Administrator, pursuant to *Sec. 13B.2.2. (Class 2 Conditional Use*

HEIGHT FRONTAGE STANDARD(S) USE DENSITY
- Industrial-Mixed Districts -

Permit) finds that drilling, testing, and proper abandonment cannot reasonably be completed within 200 days due to depth, deviation, or quantity of temporary geological exploratory core holes, the maximum duration may be increased to a total of 365 days.

10. **Animal Keeping, Bees**

- a. Bee keeping operator shall be registered as a beekeeper with the Los Angeles County Agricultural Commission.
- b. A water source for bees shall be provided at all times on the lot where the bees are kept.

D. **Supplemental Procedures**

1. **Alcohol Service or Bar**

- a. In addition to the notification otherwise required by *Sec. 13B.2.2. (Class 2 Conditional Use Permit)*, the Zoning Administrator shall promptly notify the Council-member that represents the area including the project site of the conditional use application.
- b. In addition to the findings otherwise required by *Sec. 13B.2.2. (Class 2 Conditional Use Permit)*, the Zoning Administrator shall also consider:
 - i. That the granting of the application will not result in an undue concentration of uses that dispense alcoholic beverages within a 1,000-foot radius of the lot according to the California Department of Alcoholic Beverage Control's guidelines for undue concentration.
 - ii. Consider the existing crime rate nearby, especially those crimes involving public drunkenness, the illegal sale or use of narcotics, drugs or alcohol, disturbing the peace, and disorderly conduct, and whether revocation or nuisance proceedings have been initiated for any similar use in the area.
 - iii. That the proposed use will not detrimentally affect nearby Residential Use Districts or sensitive uses.
- c. Permission for multiple approvals to allow alcohol service for three or more tenant spaces may be applied for under a single conditional use permit entitlement, subject to the following:
 - i. Tenant spaces are maintained under a single ownership within a unified complex comprising a combined floor area of 10,000 square feet or greater on the same site.
 - ii. The entitlement application for multiple conditional use permits shall be subject to processes and procedures required by *Sec. 13B.2.2. (Class 2 Conditional Use Permit)*.
 - iii. Project Review shall be completed for each individual tenant space resulting in approval for each individual tenant space prior to the establishment of the proposed use within the subject tenant space.

- iv. Applications shall detail the square footage of each tenant space, suite or unit number, hours of operation, and specific nature of proposed use for each tenant-operator space.
- v. Each individual tenant space shall be separately addressed with applicable site-specific conditions. Any change in tenant-operator shall be required to apply for Project Review in order to evaluate the applicability of existing conditions and review any potential changes in site operations and conditions.

2. Retail, Alcohol

- a. In addition to the notification otherwise required by *Sec. 13B.2.2. (Class 2 Conditional Use Permit)*, the Zoning Administrator shall promptly notify the Council-member that represents the area including the project site of the conditional use application.
- b. In addition to the findings otherwise required by *Sec. 13B.2.2. (Class 2 Conditional Use Permit)*, the Zoning Administrator shall also consider:
 - i. That the granting of the application will not result in an undue concentration of uses that dispense alcoholic beverages within a 1,000-foot radius of the lot according to the California Department of Alcoholic Beverage Control’s guidelines for undue concentration.
 - ii. Consider the existing crime rate nearby, especially those crimes involving public drunkenness, the illegal sale or use of narcotics, drugs or alcohol, disturbing the peace, and disorderly conduct, and whether revocation or nuisance proceedings have been initiated for any similar use in the area.
 - iii. That the proposed use will not detrimentally affect nearby Residential Use Districts or sensitive uses

3. Retail, Firearms

In addition to the findings otherwise required by *Sec. 13B.2.2. (Class 2 Conditional Use Permit)*, the Zoning Administrator shall also consider the number of firearms available for sale at the lot.

4. Retail, Large Format

- a. In addition to a Conditional Use Permit with approval by the City Planning Commission, pursuant to *Sec. 13B.2.3. (Class 3 Conditional Use Permit)*, new large format retail uses are required to prepare an economic impact analysis report for submission to the Department of City Planning and the Economic & Workforce Development Department for review in conjunction with its application to the Department of City Planning. The Economic & Workforce Development Department shall complete its review of the report within 60 days after receipt of the report from the applicant. The report shall identify the following:

FORM FRONTAGE STANDARDS | USE DENSITY |
- Industrial-Mixed Districts -

- i. The economic impact on retail businesses within a 3-mile radius based on the potential to divert or expand the local or regional customer base. Data portraying the existing customer volume of the study area as well as the anticipated customer volume of the study area shall be included in the report.
 - ii. The destruction or demolition of any buildings, structures facilities or site area containing any of the following uses: any Residential Use, Civic Facility, School, Nature Reserve, Public Open Space, or Public Recreation.
 - iii. Contribution to local retail market in terms of providing lower in cost or higher in quality goods and services than currently available to residents within a 3-mile radius. A survey of goods and services offered by retail uses within a 3-mile radius shall be included within the report.
 - iv. The number of permanent jobs displaced or created as a direct result of the project. Permanent jobs shall be categorized by employment sector within the report.
 - v. Fiscal impact on City tax revenue, either positive or negative.
 - vi. Viability of future reuse of the project site in the event the business vacates the premises based on factors such as building design, site layout, and lease terms requiring the lot to remain vacant for a significant amount of time.
 - vii. Reasonable expectation that employment solicitation by day laborers will occur at or around the lot.
 - viii. Measures to mitigate any materially adverse impacts identified within the report.
- b. If determined by the City Planning Commission, or the City Council on appeal, that based on the findings of the report, or any other information received before or at a public hearing that there is a reasonable expectation that employment solicitation by day laborers will occur at or around the lot then the following measures may be required to the satisfaction of the City Planning Commission, or the City Council on appeal:
- i. The project shall accommodate employment solicitation by day laborers with dedicated congregation space that meets the following criteria:
 - a) Is sufficient in size based on reasonably expected users;
 - b) Located along but clear of a pedestrian accessway leading to a primary entrance;
and
 - c) Is covered to provide adequate shelter from the weather.
 - ii. Amenities including publicly accessible sources of drinking water, toilet and trash facilities, tables, and seating areas shall also be made available during business hours of operation.

